



# Allen-Bradley

## 1609-PSB1

### Service Bypass Switch

Entire contents copyright © 2006 by Rockwell Automation corporation. All rights reserved. Reproduction in whole or in part without permission is prohibited. A-B and Allen-Bradley are registered trademarks of Rockwell Automation Corporation. All other trademarks are the property of their respective owners.

90-007 rev 1

Note: Read the safety information sheet before installation.

Illustrations in this document may differ slightly from the actual hardware.

**Attention: This product is for use in a controlled environment. Refer to product specifications for environmental limits.**

#### RACK MOUNTING

1

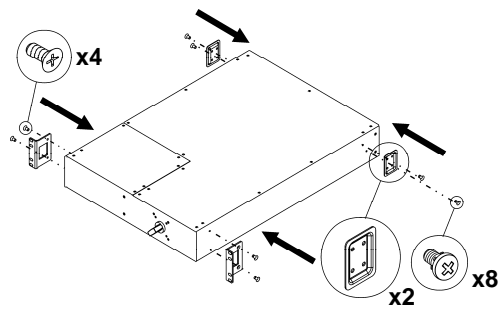

2 Set SBP in the rack. If hardwiring is required, see *Connecting Power* section before screwing into the rack.

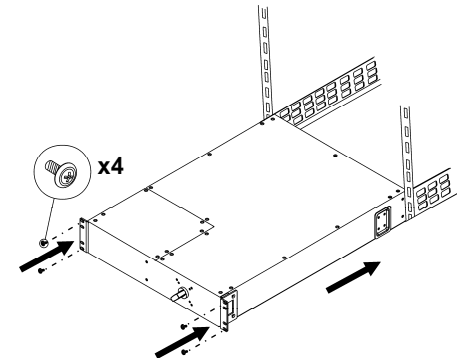

#### 1 WALL MOUNTING

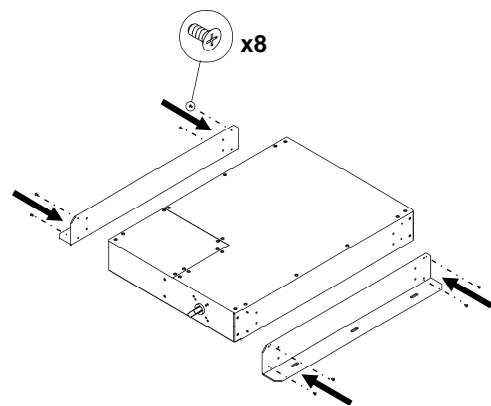

41063-300-01(1)

2 Whenever possible, attach one top screw and one bottom screw into a wall stud. If stud mounting is not possible, use an expandable wall anchor. **Screws are not included;** .25" x 2" lag bolts are recommended.

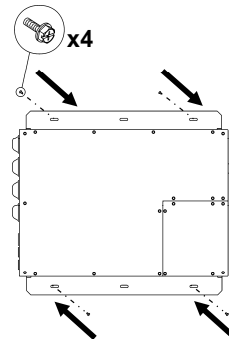

#### TOWER OPTION

1 Remove screw from the top and bottom rear of both the UPS and SBP. Install tie brackets and reattach screws.

Front

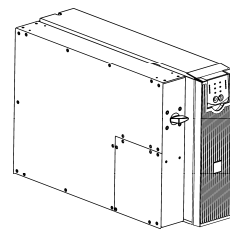

Rear

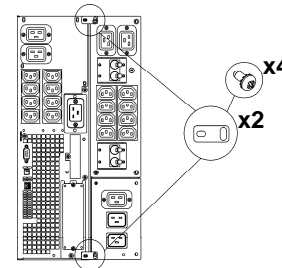

2 Unscrew and remove top cover of the UPS.

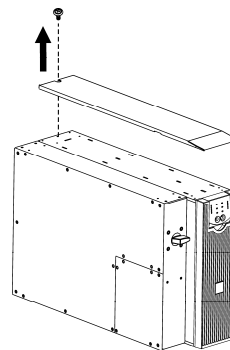

3 Attach bracket to top of UPS and SBP.

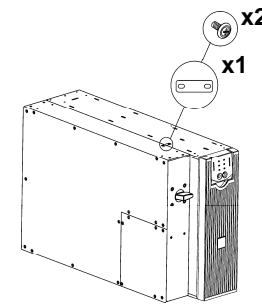

4 Reattach top cover of the UPS.

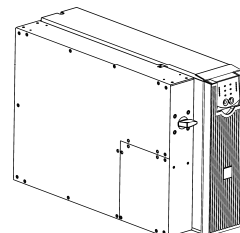
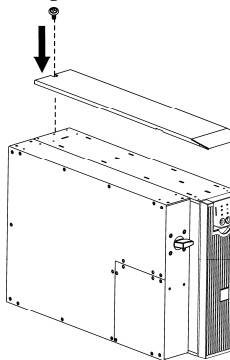

Note: The 1609-SBP1, when used in conjunction with an 1609-P3000A or 1609-P5000E UPS in a tower configuration without an external battery pack 1609-PXBP, is suitable for mounting on concrete or other non-combustible smooth surfaces only.

41063-300-01(1)

#### USER CONFIGURABLE

**Attention: When using an online UPS, put the UPS in automatic bypass mode before rotating the SBP switch.**

1. **Normal:** Power is directed from the utility outlet, through the Bypass Panel and UPS, and to connected equipment. For use during normal UPS operation.

2. **Test:** Power supplied to the UPS is not output. Use when tests are being conducted on the UPS, and connected equipment is not yet desired.

3. **Bypass:** Power from the utility outlet is filtered through the Bypass Panel, and to the connected equipment. Use to bypass the UPS, when functioning improperly.

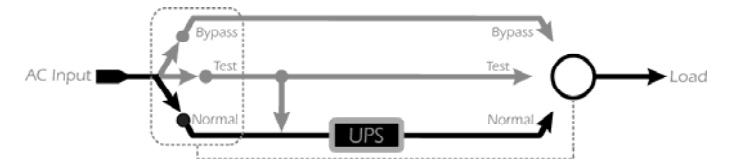

Note: While operating in 'Test' or 'Bypass' mode, power to the connected equipment is not conditioned by the UPS. At this time, the "Equipment Protection Policy" is not valid.

#### IDENTIFYING THE PANEL

Service Bypass Panels will differ. Refer to chart for unit specifications.

Note: HW= Hardwire

Service Bypass Panel	Corresponding UPS Systems	Bypass Input	UPS Input	UPS Output	PDU Panel
1609-PSB1	1609-P3000A 1609-P3000H 1609-P5000E 1609-P8000E 1609-P10000E	HW (1Ph)	HW (1Ph)	HW	HW

\*For loads exceeding 3kVA, hardwiring is necessary.

41063-300-01(1)

## CONNECTING POWER

**Warning: Do not modify inlets or outlets. The SBP and UPS plugs and receptacles should match. For more information, contact Rockwell Automation.**

### 1. Non-Hardwired Panels

1. Plug SBP UPS output cord into UPS PDU panel.\*
2. Plug UPS input cord to SBP UPS input receptacle.\*
3. Plug customer equipment into SBP PDU panel.
4. Plug SBP into utility power outlet.

\*Units with IEC receptacles: Use jumper cables.

### 2. Hardwired Panels

**Attention: Wiring must be performed by a qualified electrician.**

1. Switch input circuit breaker off.
2. *SBP units that will be rack-mounted:* Set SBP in the rack.
3. Unscrew and remove top access panel.
4. *If using 1609-P5000E or 1609-P8000E with a hardwired UPS:* Unscrew existing terminal block wiring. Do not touch factory wiring (see **E**).
5. *If using 1609-P5000E or 1609-P8000E with a hardwired UPS:* Unscrew and remove rear input/output panel.
6. Remove circular knockouts from hardwiring input/output panel (see **A**: UO= UPS Output; UI= UPS Input; AI= AC Input; LD= Load).

*1609-PSB1 units:* Also, remove circular knockouts from PDU output panel.

7. Connect wires to terminal blocks (see **B**). Adhere to all national and local electrical codes.
8. Reinstall access panel.
9. Install hardwiring input/output panel.
10. *SBP units that will be rack-mounted:* Screw SBP into the rack.

#### A.

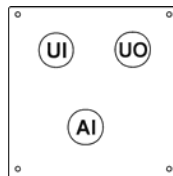

#### B. 1609-PSB1

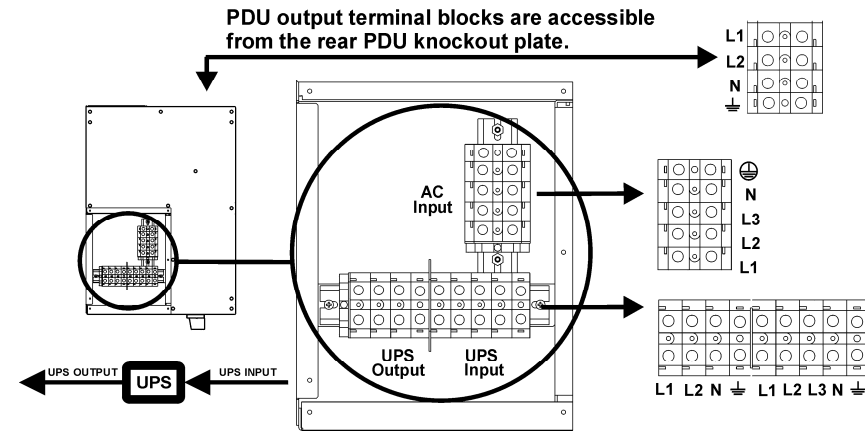

## TROUBLESHOOTING

Use the chart below to solve minor SBP installation problems. Also, refer to the UPS User Manual *Troubleshooting* section.

Problem and Possible Cause	Solution
<b>UPS WILL NOT TURN ON AFTER ON BUTTON IS PUSHED</b>	
SBP handle is in 'Bypass' position.	Rotate the SBP handle to the 'Normal' position.
There is no power at UPS input.	Check that the power cables from the SBP to the utility power, and from the SBP to the UPS Input are securely connected.
UPS is faulty or damaged.	Rotate the SBP handle into the 'Test' position. If the connected equipment becomes energized, the UPS may be faulty. To confirm this, refer to UPS User Manual <i>Troubleshooting</i> .
There is no power at the utility power outlet.	Rotate the SBP handle into the 'Test' position. If the connected equipment fails to become energized, the utility power outlet may be faulty. Check the utility power supply by plugging a table lamp into the suspect outlet. If the utility outlet fails to power the lamp, contact qualified service personnel to restore power.
<b>UPS IS ONLINE; NOT POWERING ALL CONNECTED EQUIPMENT</b>	
SBP output circuit breaker tripped.	Reduce the load by unplugging equipment. Reset the breaker.
There is no power at SBP output.	Check that the power cable from the SBP to the UPS output is securely connected.