



8 and 16 Point Relay Master Interface Modules

Module Relais d'interface

Relais-Schnittstellenmodule

Moduli di Interfaccia di Relay

Módulos de Interface de Relés

(Cat 1492-XIM4024-8R, -XIM4024-16R, -RXIM4024-16R)



ATTENTION: To prevent electrical shock, disconnect from power source before installing or servicing.
ATTENTION: Avant le montage et la mise en service, couper l'alimentation secteur pour éviter toutes décharges.
ACHTUNG: Vor Installations- oder Servicearbeiten Strom-versorgung unterbrechen, um Elektroschocks zu vermeiden.
ATTENZIONE: Per prevenire infortuni, togliere tensione prima dell'installazione o manutenzione.
ATENCION: Desconéctese de la corriente eléctrica, antes de la instalación o del servicio, a fin de impedir sacudidas eléctricas.

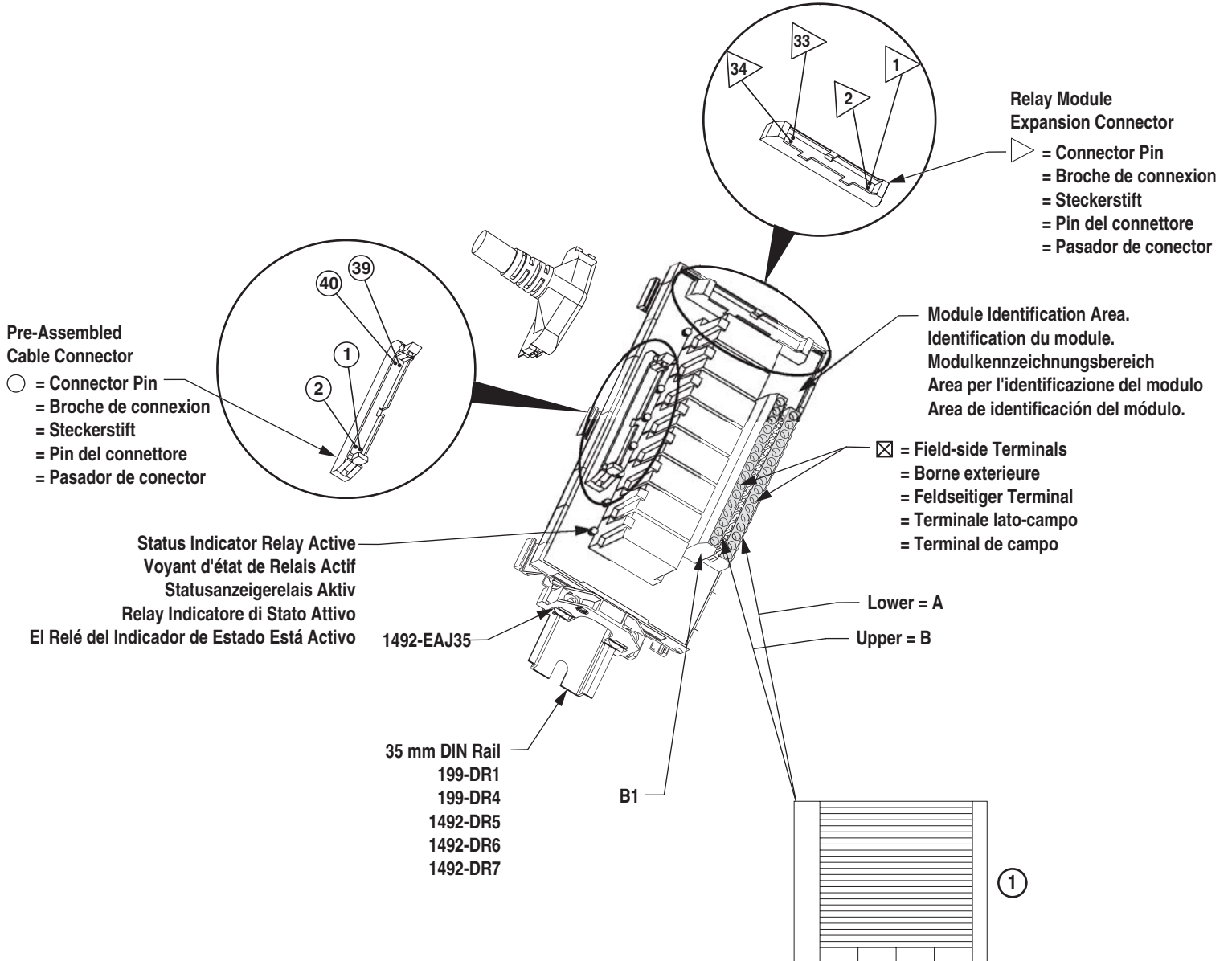

- ① **Adhesive Label Card. Provides terminal wiring identification.**
 Carte étiquette adhésive. Identifie le câblage des bornes.
 Aufklebbare Etiketten zur Kennzeichnung der Klemmenverdrahtung.
 Scheda etichette adesive. Fornisce l'identificazione del cablaggio dei terminali.
 Tarjeta de etiquetas adhesivas. Proporciona identificación de cableado del terminal.

Module
 Installation / Removal
 Montage / Retrait
 Installation / Entfernen
 Montaggio / Smontaggio
 Instalación / Extracción

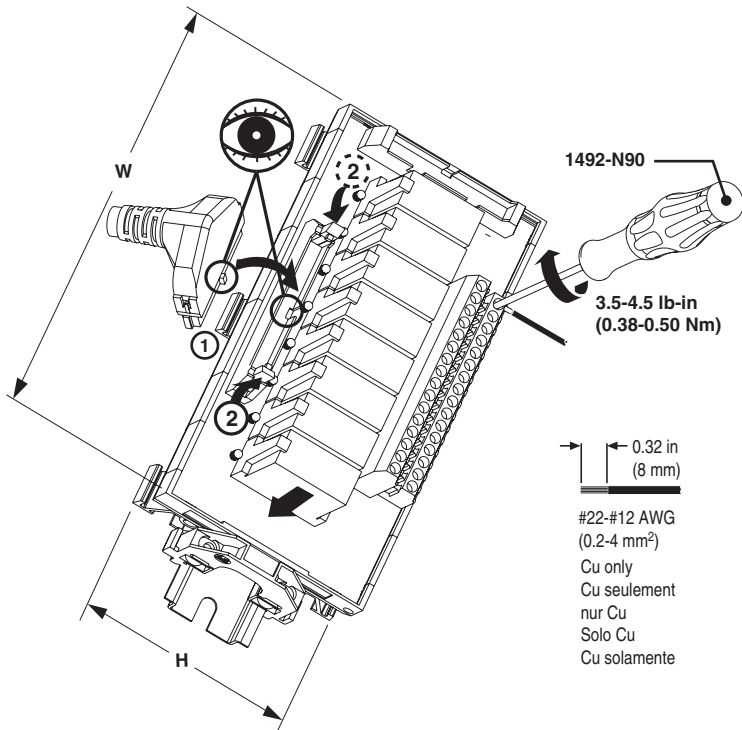

Applies to modules with fixed and removable (R) terminal block

Removable Terminal Block
 Installation / Removal
 Montage / Retrait
 Installation / Entfernen
 Montaggio / Smontaggio
 Instalación / Extracción

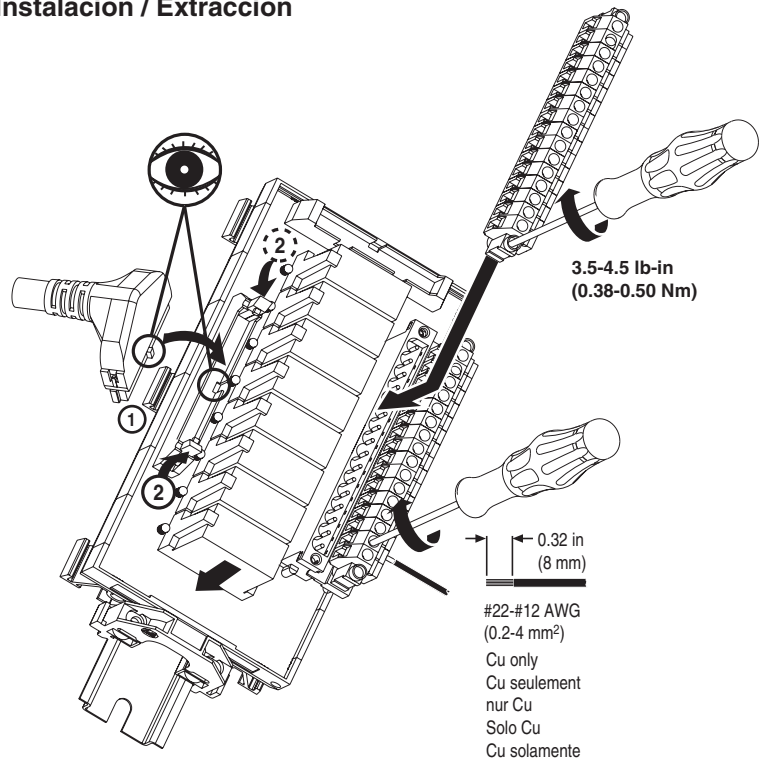

Applies to modules with removable terminal block plugs (1492-RXIM_)

Cable Matrix
 Matrice des câbles
 Kabelmatrix
 Matrice cavi
 Matriz de cables

I/O Module Module E/S E/A-Modul Modulo I/O Módulo de E/S	1492-XIM4024-8R	1492-XIM4024-16R 1492-RXIM4024-16R ^②
1746-OB32	1492-CABLE ^① H	1492-CABLE ^① H
1746-OB32E	1492-CABLE ^① H	1492-CABLE ^① H
1756-OB32	1492-CABLE ^① Z	1492-CABLE ^① Z
TC-ODD321	1492-HWCAB ^① Z	1492-HWCAB ^① Z
1769-OB32	1492-CAB ^① K69	1492-CAB ^① K69
1769-OB32T	1492-CABLE ^① H	1492-CABLE ^① H
1771-OBN	1492-CABLE ^① L	1492-CABLE ^① L

① Cables are available in 0.5m, 1.0m, 2.5m and 5.0m lengths (005=0.5m, 010=1.0m, 025 = 2.5m, 050=5.0m). Custom length cables also available. Contact local Sales Office for more information.

Câbles disponibles en 0,5m, 1,0m, 2,5m et 5,0m de longueur (005=0,5m; 010=1,0m; 025=2,5m; 050=5,0m). Câbles sur mesure à la demande. Contactez le bureau le plus proche.

Verfügbare Kabellängen 0,5m, 1,0m, 2,5m und 5,0m (005=0,5m; 010=1,0m; 025=2,5m; 050=5,0m).

Anwenderspezifische Längen stehen ebenfalls zur Verfügung. Kontaktieren Sie bitte Ihr lokales Vertriebsbüro für weitere Informationen.

I cavi sono disponibili in lunghezze di 0,5m, 1,0m, 2,5m e 5,0m (005=0,5m; 010=1,0m; 025=2,5m; 050=5,0m). Sono disponibili anche cavi su misura. Per ulteriori informazioni, contattare l'ufficio vendite locale.

Cables disponibles en longitudes de 0,5m, 1,0m, 2,5m, 5,0m (005=0,5m; 010=1,0m; 025=2,5m; 050=5,0m).

Hay disponibles cables de varias longitudes. Para más información comuníquese con la oficina de ventas.

② Supports Removable Terminal Block (RTB) plug. Compatible screw style plug, 1492-RTB14N (Pkg. qty. 2). Compatible push-in style plug 1492-RTB14P (pkg. qty. 2). Order plugs separately.

Pinout
Brochage
Anschlußbelegung
Disposizione
dei piedini
Esquema de pins

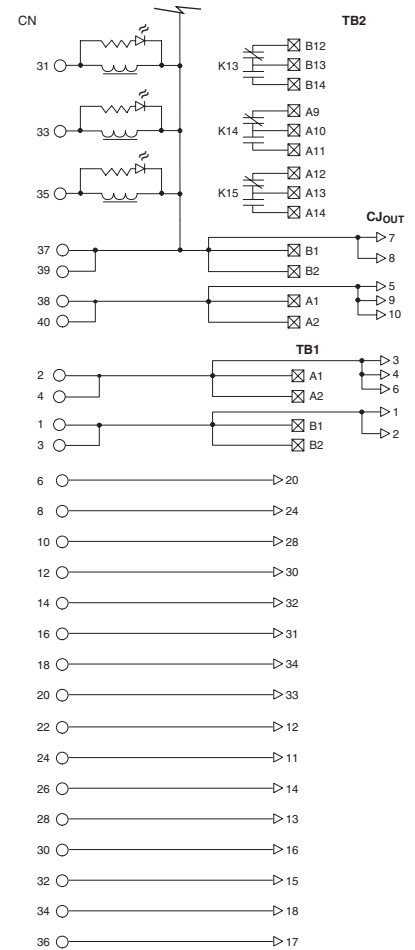
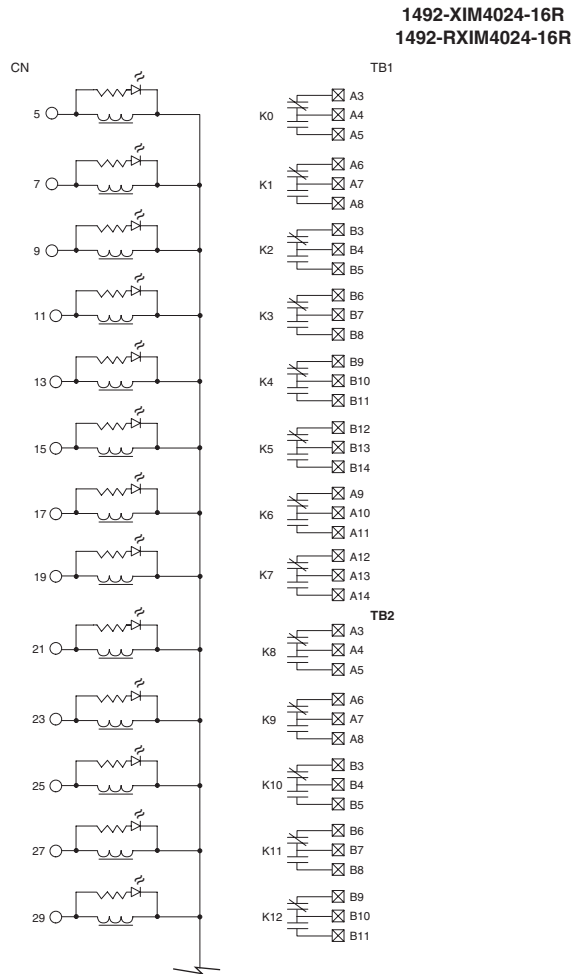
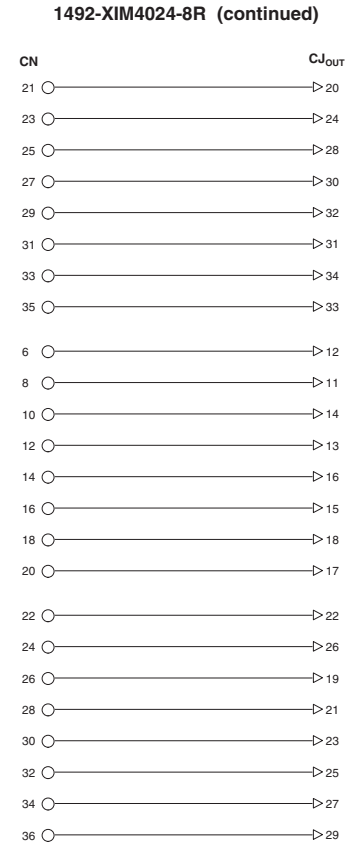
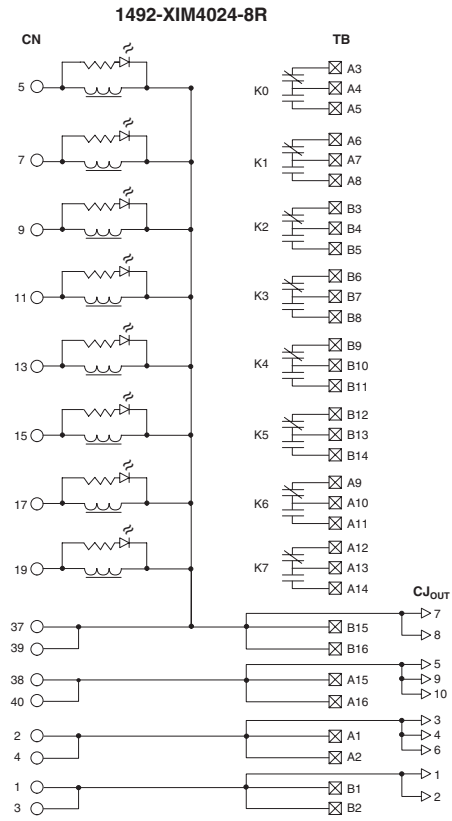

Wiring
Câblage
Verdrahtung
Cablaggio
Cableado

Important: Wiring diagrams are online at www.ab.com/e-tools.
Important: Les schémas et sont disponibles en ligne à l'adresse www.ab.com/e-tools.
Wichtig: Die Schaltpläne finden und unter der Internet-Adresse www.ab.com/e-tools.
Importante: Gli schemi di cablaggio sono illustrati, oppure online all'indirizzo www.ab.com/e-tools.
Importante: Los diagramas de conexiones están en y se encuentran en-línea en www.ab.com/e-tools.

Specifications **Technische Daten** **Especificaciones**
Spécifications **Specifiche**

Catalog No. Référence Bestell-Nr. N. Catalogo Referencia	Voltage Tension Spannung Tensione Voltaje	Indicator Circuit Current Courant circuit voyants Strom, Anzeigeschaltkreis Corrente circuito indicatori Intensidad del circuito de indicadores	Operating Temperature Range Plage températures de fonctionnement Betriebstemperaturbereich Limiti temperatura di funzionamento Rango de temperatura de funcionamient
1492-XIM4024-8R 1492-XIM4024-16R 1492-RXIM4024-16R	20-26 VDC	2.0 mA	0° C - 60° C

Catalog No. Référence Bestell-Nr. N. Catalogo Referencia	Maximum Recurring Peak Voltage ② Tension de crele réurrente maximale Maximale periodische Hochstspannung Tensione massima di cresta ricorrente Voltaje de cresta iterativo máximo	Humidity Humidité Feuchtigkeit Humedad Umidità	Approx. Shipping Weight Poids d'embarquement approximatif Ungefähres Versandgewicht Peso approssimativo del carico Peso aproximado al momento de embarque	Dimensions Dimensions Abmessungen Dimensioni Dimensiones	Standards Normes Standards Standard Estándares
1492-XIM4024-8R 1492-XIM4024-16R 1492-RXIM4024-16R	600 Vp②	5 - 95% ③	1.18 lb. 536 g. 1.79 lb. 811 g.	6.30 in. (160 mm) W 3.27 in. (83 mm) H 2.78 in (70.5 mm) D 9.06 in. (230 mm) W 3.27 in. (83 mm) H 2.78 in (70.5 mm) D	cULus (File: E113724, Guide No. NRAQ CE: Compliant for all applicable directives FM Class 1 Div 2 Groups A, B, C and D Temperature Rating T3C = 60°C (J.I. 3000590, all except relay modules)

② For transients > 600 Vp use a UL recognized suppression device rated at 2.5 kV withstand.
 Pour des transitoires > 600 Vp utilisez un dispositif de suppression certifié UL à 2,5 kV nominal de tenue.
 Für Einschaltstöße > 600 Vp verwenden Sie einen UL anerkannten Entstörer, der bewertet wurde bei 2,5 kV standzuhalten.
 Per transitori > 600 Vp usare dispositivo di soppressione riconosciuto da UL capace di sopportare 2,5 kV.
 Para transitorios > 600 Vp use un dispositivo de supresión reconocido UL clasificado con 2,5 kV.

③ Non-condensing
 Sans condensation
 Nicht kondensierend
 Senza condensa
 sin condensación

SURGE SUPPRESSION follow the literature recommendations of the PLC module being used.
SUPPRESSION DES SURTENSIONS se trouve à la suite de la littérature qui contient les recommandations relatives au module PLC utilisé.
ÜBERSpannungSSCHUTZ Bitte beachten Sie die Dokumentationsempfehlungen für das jeweils benutzte SPS-Modul.
 Per la **SOPPRESSIONE DEI PICCHI TEMPORANEI**, seguire le istruzioni riportate nella documentazione in dotazione al Modulo PLC utilizzato.
SUPRESIÓN DE SOBRETENSIÓN, siga las recomendaciones indicadas en la documentación del módulo PLC respectivo.

Relay Contact Rating **Relaiskontakt-Nennwerte** **Capacidad Nominal del Contacto de Relé**
Spécification du Contact à Relais **Classificazione Contatti di Relay**

Voltage Tension Spannung Tensione Voltaje	Minimum Current Intensité Minimale Mindeststrom Corrente minima Corriente mínima	▶ ◀ ◀ ▶	HP	Resistive Load Charge résistive Widerstandslast Carico resistivo Carga resistiva	Contact Resistance Résistance de contact Kontaktwiderstand Resistenza al contatto Resistencia de los contactos	Operate Time Temps de déclenchement Abfallzeit Ora rilascio Tiempo de liberación	Release Time Temps de fonctionnement Einschaltzeit Tempo di funzionamento Tiempo de operación	Operating Frequency Fréquence de fonctionnement Betriebsfrequenz Frequenza di funzionamento Frecuencia de operación	
120VAC 240VAC 30VDC	0.05 Amps @ 10V AC/DC	30 Amps 10 Amps 10 Amps	3 Amps 1.5 Amps 10 Amps	1/3 1/2 NA	10 Amps ③	30mΩ Max.	15ms Max.	15ms AC 10ms DC	1800/hr

③ Maximum continuous current for two adjacent relays is 12 Amps.
 Le courant permanent maximum pour deux relais adjacents est de 12 A.
 Der maximale Dauerstrom für zwei nebeneinanderliegende Relais beträgt 12 A.
 La corrente continua massima per due relè adiacenti è di 12 ampere.
 La corriente continua máxima para dos relés adyacentes es de 12 A.

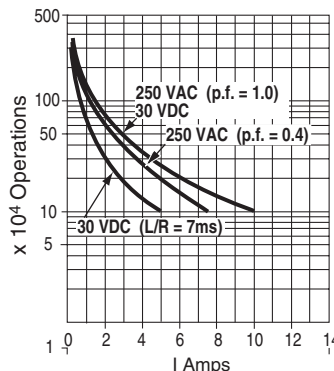

Service Life
Durée de service
Nutzungsdauer
Vita utile
Duración de vida útil

Reference Publications: Refer to 1770-4.1 and appropriate PLC I/O module installation manual.