



# 16 Point isolated Interface Modules with LEDs and Extra Terminals

## Modules d'interface isolés 16 points avec voyants et terminaisons supplémentaires

### Isolierte 16-Punkt-Schnittstellenmodule mit LEDs und zusätzlichen Terminals

#### Moduli di interfaccia isolati a 16 punti con LED e terminali extra

#### Módulos de interfaz aislado con LED y terminales adicionales (16 puntos)

(Cat 1492-IFM40DS24-4, -IFM40DS120-4)



**ATTENTION:** To prevent electrical shock, disconnect from power source before installing or servicing. FM Class 1, Div.2 requires device installation in a tool-accessible enclosure compliant with ANSI/ISA S82.

**ATTENTION:** Avant le montage et la mise en service, couper l'alimentation secteur pour éviter toutes décharges. FM Classe 1, Div. 2 nécessite l'installation de l'équipement dans une armoire accessible aux interventions, conforme à ANSI/ISA S82.

**ACHTUNG:** Vor Installations- oder Servicearbeiten Strom-versorgung unterbrechen, um Elektroschocks zu vermeiden. FM-Klasse 1, Gruppe 2 erfordert die Installation des Gerätes in einem Gehäuse, das für Werkzeuge zugänglich ist und den Anforderungen gemäß ANSI/ISA S82 entspricht.

**ATTENZIONE:** Per prevenire infortuni, togliere tensione prima dell'installazione o manutenzione. FM Classe 1, Divisione 2 richiede l'installazione del dispositivo in un alloggiamento con capacità di accesso per strumenti conforme allo standard ANSI/ISA S82.

**ATENCION:** Desconéctese de la corriente eléctrica, antes de la instalación o del servicio, a fin de impedir sacudidas eléctricas. El requisito de FM (Factory Mutual) Clase 1, Div. 2, establece que el dispositivo debe instalarse en un envoltorio que permita la introducción y uso de herramientas y cumpla con la norma ANSI/ISA S82.

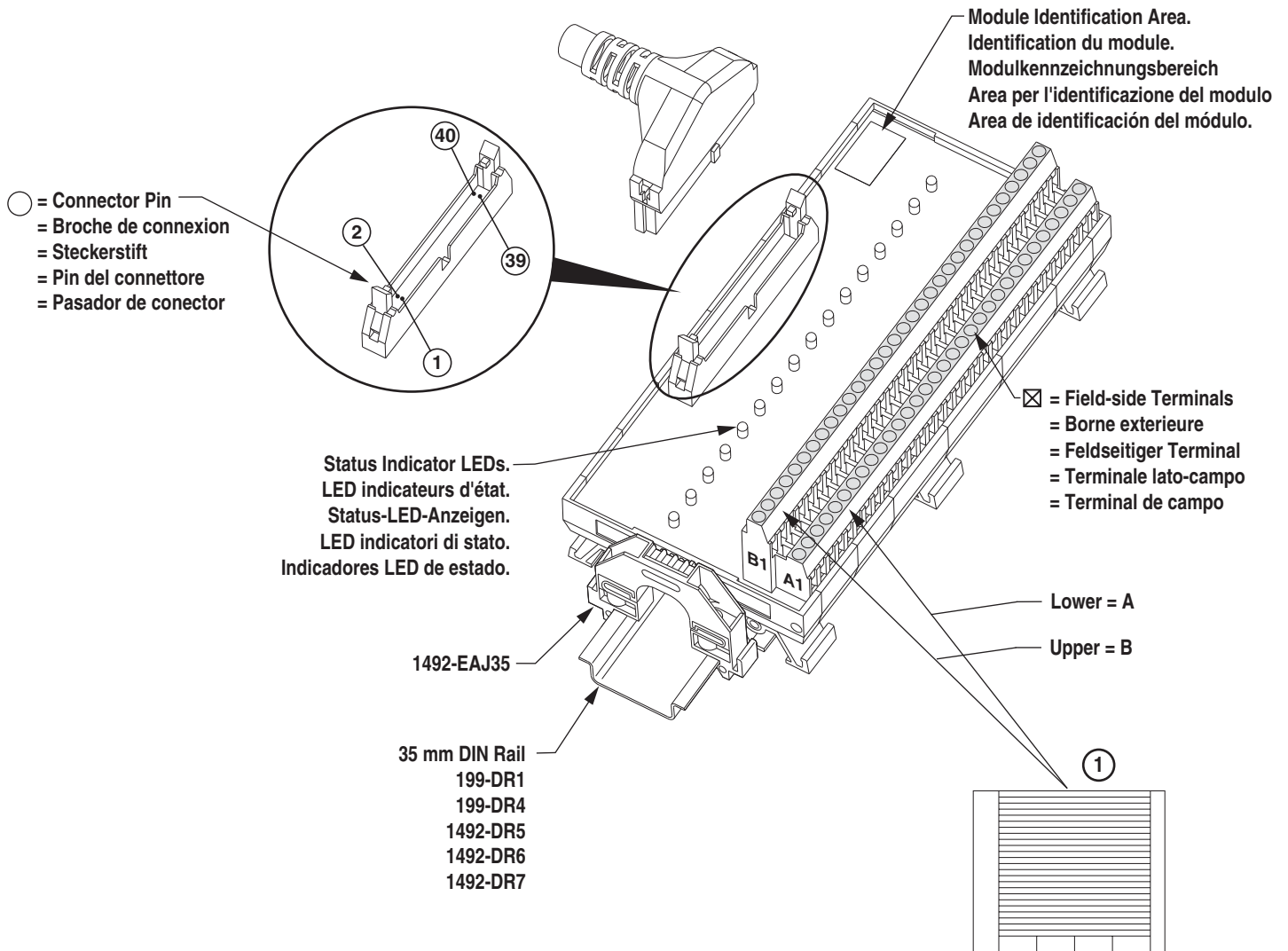

- ① **Adhesive Label Card. Provides terminal wiring identification.**  
 Carte étiquette adhésive. Identifie le câblage des bornes.  
 Aufklebbare Etiketten zur Kennzeichnung der Klemmenverdrahtung.  
 Scheda etichette adesive. Fornisce l'identificazione del cablaggio dei terminali.  
 Tarjeta de etiquetas adhesivas. Proporciona identificación de cableado del terminal.

**Installation**  
**Montage**  
**Installation**  
**Montaggio**  
**Instalación**

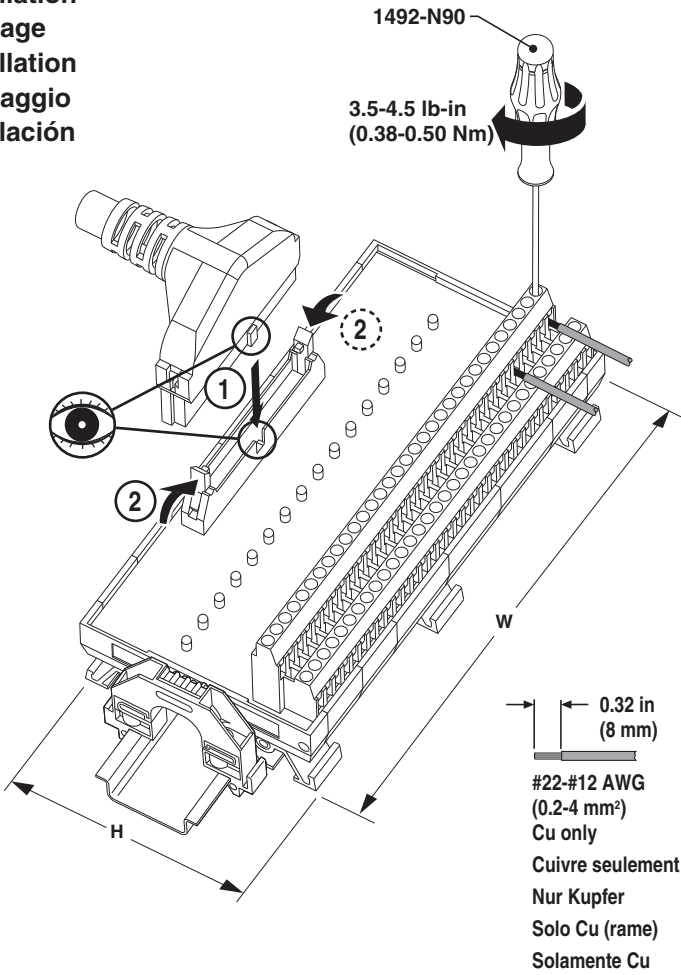

**Removal**  
**Retrait**  
**Entfernung**  
**Smontaggio**  
**Extracción**

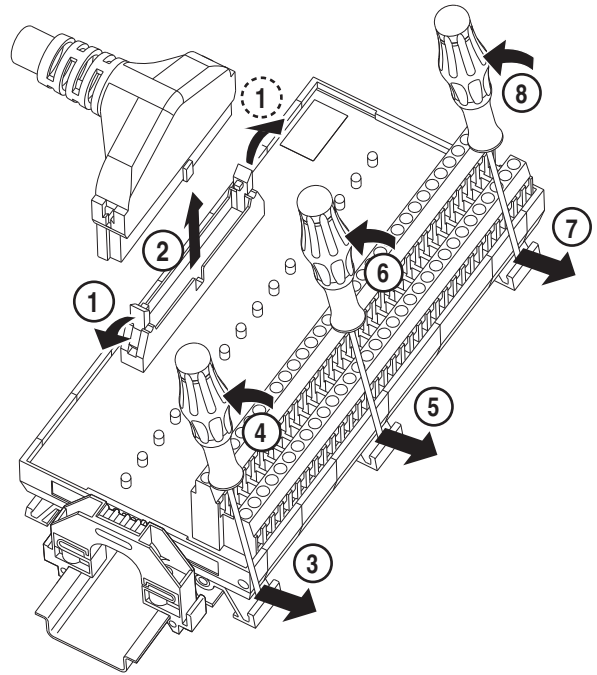

**Cable Matrix**  
**Tableau des câbles**  
**Kabelmatrix**  
**Matrice dei cavi**  
**Matriz de cables**

I/O Module Module E/S E/A-Modul Modulo I/O Módulo de E/S	1492-IFM40DS24-4	1492-IFM40DS120-4
1756-OA16I TC-ODK16I		1492-CABLEⓈY
1756-OB8EI	1492-CABLEⓈY	
1756-OB16D TC-ODX16I	1492-CABLEⓈY	
1756-OB16I TC-ODJ16I	1492-CABLEⓈY	
1756-OB16IS	1492-CABLEⓈY	
1756-OW16I TC-ORC16I	1492-CABLEⓈY	1492-CABLEⓈY
1756-OX8I TC-ORC08I	1492-CABLEⓈY	1492-CABLEⓈY
1771-OD16		1492-CABLEⓈM
1771-ODD		1492-CABLEⓈM
1771-OQ16	1492-CABLEⓈM	

- ① Cables are available in .5m, 1.0m, 2.5m and 5.0m lengths (005=.5m, 010=1.0m, 025 = 2.5m, 050=5.0m).  
 Câbles disponibles en 0,5m; 1,0m; 2,5m et 5,0m de longueur (005=0,5m; 010=1,0m; 025=2,5m; 050=5,0m).  
 Verfügbare Kabellängen 0,5m; 1,0m; 2,5m und 5,0m (005=0,5m; 010=1,0m; 025=2,5m; 050=5,0m).  
 I cavi sono disponibili in lunghezze di 0,5m, 1,0m, 2,5m e 5,0m (005=0,5m; 010=1,0m; 025=2,5m; 050=5,0m).  
 Cables disponibles en longitudes de 0,5m, 1,0m, 2,5m, 5,0m (005=0,5m; 010=1,0m; 025=2,5m; 050=5,0m).

Custom length cables also available. Contact local Sales Office for more information.  
 Câbles sur mesure à la demande. Contactez le bureau le plus proche.  
 Anwenderspezifische Längen stehen ebenfalls zur Verfügung. Kontaktieren Sie bitte Ihr lokales Vertriebsbüro für weitere Informationen.  
 Sono disponibili anche cavi su misura. Per ulteriori informazioni, contattare l'ufficio vendite locale.  
 Hay disponibles cables de varias longitudes. Para más información comuníquese con la oficina de ventas.

**Pinout**  
**Brochage**  
**Anschlußbelegung**  
**Disposizione dei piedini**  
**Esquema de pins**

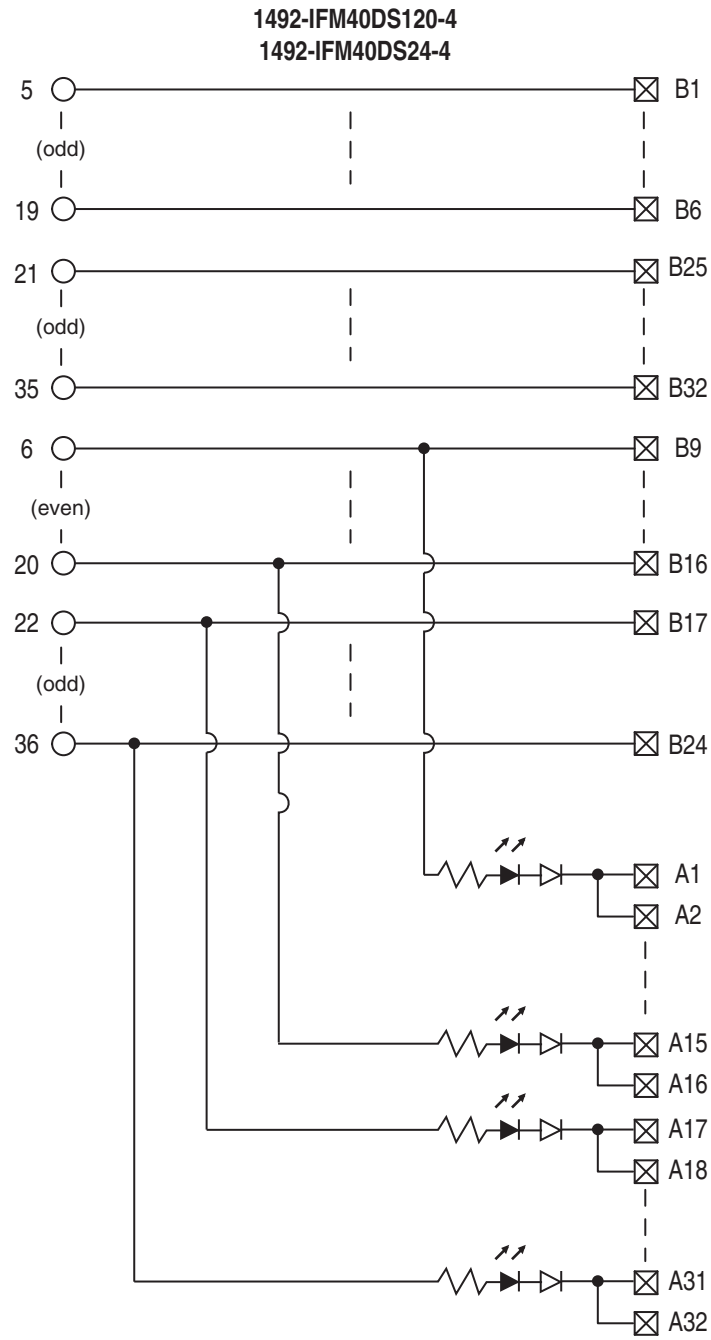

**Wiring**  
**Câblage**  
**Verdrahtung**  
**Cablaggio**  
**Cableado**

**Important:** Wiring diagrams are online at [www.ab.com/e-tools](http://www.ab.com/e-tools).  
**Important:** Les schémas et sont disponibles en ligne à l'adresse [www.ab.com/e-tools](http://www.ab.com/e-tools).  
**Wichtig:** Die Schaltpläne finden und unter der Internet-Adresse [www.ab.com/e-tools](http://www.ab.com/e-tools).  
**Importante:** Gli schemi di cablaggio sono illustrati, oppure online all'indirizzo [www.ab.com/e-tools](http://www.ab.com/e-tools).  
**Importante:** Los diagramas de conexiones están en y se encuentran en-línea en [www.ab.com/e-tools](http://www.ab.com/e-tools).

**Specifications**      **Technische Daten**      **Especificaciones**  
**Spécifications**      **Specifiche**

Catalog No. Référence Bestell-Nr. N. Catalogo Referencia	Voltage Tension Spannung Tensione Voltaje	Current/Circuit Courant/Circuit Strom/Schaltkreis Corrente/circuito Intensidad/circuito	Current/Module Courant/Module Strom/Modul Corrente/modulo Intensidad/módulo	Indicator Circuit Current Courant circuit voyants Strom, Anzeigeschaltkreis Corrente circuito indicatori Intensidad del circuito de indicadores	Maximum Recurring Peak Voltage ② Tension de crele réurrente maximale Maximale periodische Hochstspannung Tensione massima di cresta ricorrente Voltaje de cresta iterativo máximo
1492-IFM40DS24-4	10-60 VAC/DC	2 Amps	12 Amps	< 4.1 mA	600 V <sub>p</sub> ②
1492-IFM40DS120-4	85-132 VAC			<2.6 mA	

Catalog No. Référence Bestell-Nr. N. Catalogo Referencia	Operating Temperature Range Plage températures de fonctionnement Betriebstemperaturbereich Limiti temperatura di funzionamento Rango de temperatura de funcionamient	Operating Humidity Humidité relative Betriebsluftfeuchtigkeit Umidità di esercizio Humedad operativa	Approx. Shipping Weight Poids d'embarquement approximatif Ungefähres Versandgewicht Peso approssimativo del carico Peso aproximado al momento de embarque	Dimensions Dimensions Abmessungen Dimensioni Dimensiones	Standards Normes Standards Standard Estándares
1492-IFM40DS24-4 1492-IFM40DS120-4	0° C - 60° C	5 - 95% ③	1.15 lb. 525 g.	6.69 in. (170 mm) W 3.27 in. (83 mm) H 2.78 in (70.5 mm) D	cULus (File: E10314, Guide No. NRAG) Class 1 Div 2 Groups A, B, C and D Hazardous Locations. Temperature Code = T3C at 60°C ④ CE: Compliant for all applicable directives FM Class 1 Div 2 Groups A, B, C and D Temperature Rating T3C = 60°C (J.I. 3000590, all except relay modules)

② For transients > 600 Vp use a UL recognized suppression device rated at 2.5 kV withstand.  
 Pour des transitoires > 600 Vp utilisez un dispositif de suppression certifié UL à 2,5 kV nominal de tenue.  
 Für Einschaltstöße > 600 Vp verwenden Sie einen UL anerkannten Entstörer, der bewertet wurde bei 2,5 kV standzuhalten.  
 Per transitori > 600 Vp usare dispositivo di soppressione riconosciuto da UL capace di sopportare 2,5 kV.  
 Para transitorios > 600 Vp use un dispositivo de supresión reconocido UL clasificado con 2,5 kV.

③ Non-condensing  
 Sans condensation  
 Nicht kondensierend  
 Senza condensa  
 sin condensación

④ Power, input and output (I/O) wiring must be in accordance with Class I Division 2 wiring methods - Article 501-10(B)(1) of the National Electrical Code.



**WARNING:** Explosion Hazard - substitution of components may impair suitability for Class I Division 2.  
**WARNING:** Explosion Hazard - Do Not Disconnect Equipment unless power has been switched off or the area is known to be Non-Hazardous.

**SURGE SUPPRESSION** follow the literature recommendations of the PLC module being used.  
**SUPPRESSION DES SURTENSIONS** se trouve à la suite de la littérature qui contient les recommandations relatives au module PLC utilisé.  
**ÜBERSpannungSSchutz** Bitte beachten Sie die Dokumentationsempfehlungen für das jeweils benutzte SPS-Modul.  
 Per la **SOPPRESSIONE DEI PICCHI TEMPORANEI**, seguire le istruzioni riportate nella documentazione in dotazione al Modulo PLC utilizzato.  
**SUPRESIÓN DE SOBRETENSIÓN**, siga las recomendaciones indicadas en la documentación del módulo PLC respectivo.

Reference Publications: Refer to 1770-4.1  
 and appropriate PLC I/O module installation manual.