



Adapter Kit for PanelView Standard and PanelView “e” Terminal Cutouts

Catalog Numbers 2711P-RAK7, 2711P-RAT7, 2711P-RAK10, 2711P-RAT10, 2711P-RAK12S, 2711P-RAT12S

Language	Page
English	3
Français	9
Deutsch	15
Español	21
Italiano	27
Português	33

Important User Information

Solid state equipment has operational characteristics differing from those of electromechanical equipment. Safety Guidelines for the Application, Installation and Maintenance of Solid State Controls (publication SGI-1.1 available from your local Rockwell Automation sales office or online at <http://literature.rockwellautomation.com>) describes some important differences between solid state equipment and hard-wired electromechanical devices. Because of this difference, and also because of the wide variety of uses for solid state equipment, all persons responsible for applying this equipment must satisfy themselves that each intended application of this equipment is acceptable.





In no event will Rockwell Automation, Inc. be responsible or liable for indirect or consequential damages resulting from the use or application of this equipment.

The examples and diagrams in this manual are included solely for illustrative purposes. Because of the many variables and requirements associated with any particular installation, Rockwell Automation, Inc. cannot assume responsibility or liability for actual use based on the examples and diagrams.

No patent liability is assumed by Rockwell Automation, Inc. with respect to use of information, circuits, equipment, or software described in this manual.

Reproduction of the contents of this manual, in whole or in part, without written permission of Rockwell Automation, Inc., is prohibited.

Throughout this manual, when necessary, we use notes to make you aware of safety considerations.

<p>WARNING</p> 	<p>Identifies information about practices or circumstances that can cause an explosion in a hazardous environment, which may lead to personal injury or death, property damage, or economic loss.</p>
<p>IMPORTANT</p>	<p>Identifies information that is critical for successful application and understanding of the product.</p>
<p>ATTENTION</p> 	<p>Identifies information about practices or circumstances that can lead to personal injury or death, property damage, or economic loss. Attentions help you to identify a hazard, avoid a hazard, and recognize the consequences.</p>
<p>SHOCK HAZARD</p> 	<p>Labels may be on or inside the equipment, for example, a drive or motor, to alert people that dangerous voltage may be present.</p>
<p>BURN HAZARD</p> 	<p>Labels may be on or inside the equipment, for example, a drive or motor, to alert people that surfaces may reach dangerous temperatures.</p>



Adapter Kit for PanelView Standard and PanelView “e” Terminal Cutouts

Catalog Numbers 2711P-RAK7, 2711P-RAT7, 2711P-RAK10, 2711P-RAT10, 2711P-RAK12S, 2711P-RAT12S

English

Topic	Page
About This Publication	4
Package Contents	4
Tools Required	4
Disconnect Power to the Terminal	5
Remove the Existing Terminal	5
Attach the Adapter Plates to the Panel	5
Attach the Terminal to the Adapter Plate	7

About This Publication

This document provides instructions on how to mount the following devices into existing PanelView Standard and PanelView “e” terminal cutouts.

- PanelView Plus 700-1250
- PanelView Plus CE 700-1250

Cat. No.	This Terminal:	Fits into Existing Cutout for:
2711P-RAK7	PanelView Plus 700 Keypad PanelView Plus CE 700 Keypad	PanelView Standard 900 Keypad (2711-K9xxx)
2711P-RAT7	PanelView Plus 700 Touch PanelView Plus CE 700 Touch	PanelView Standard 900 Touch (2711-T9xxx)
2711P-RAK10	PanelView Plus 1000 Keypad PanelView Plus CE 1000 Keypad	PanelView Standard 1000 Keypad (2711-K10xxx) PanelView 1000e Keypad (2711E-K10xxx)
2711P-RAT10	PanelView Plus 1000 Touch PanelView Plus CE 1000 Touch	PanelView Standard 1000 Touch (2711-T10xxx) PanelView 1000e Touch (2711E-T10xxx)
2711P-RAK12S	PanelView Plus 1250 Keypad PanelView Plus CE 1250 Keypad	PanelView Standard 1400 Keypad (2711-K14xxx)
2711P-RAT12S	PanelView Plus 1250 Touch PanelView Plus CE 1250 Touch	PanelView Standard 1400 Touch (2711-T14xxx)

Package Contents

The cutout adapter kit includes:

- Cutout adapter plates with gasket and ball bearing spacers
- Adapter bars for plates with 3 or 4 holes
- 8 , 10, or 12, #10-32 nuts with flat washers, depending on number of studs in adapter plate

Tools Required

The following tools are required for installation:

- Socket driver with 3/8 inch socket
- Slot or Phillips screwdriver
- Torque wrench capable of 17 lb-in

Disconnect Power to the Terminal

1. Disconnect power at the source and remove the power cord from the PanelView terminal.
 2. Disconnect all communication cables from the terminal.
-

ATTENTION



Make sure the power cord of the terminal is disconnected and that all cables have been disconnected from the terminal.

Remove the Existing Terminal

1. Remove the mounting clips that secure the terminal in the panel.

TIP

The PanelView Standard and PanelView “e” mounting clips are different than the PanelView Plus mounting clips. Store the mounting clips separately to avoid confusion later.

2. Slide the existing terminal out from panel.

Attach the Adapter Plates to the Panel

The studs on the front adapter plate fit within the cutout of the terminal.

1. Place the front adapter plate into the panel cutout until the sealing gasket material is firmly against the front of the panel.

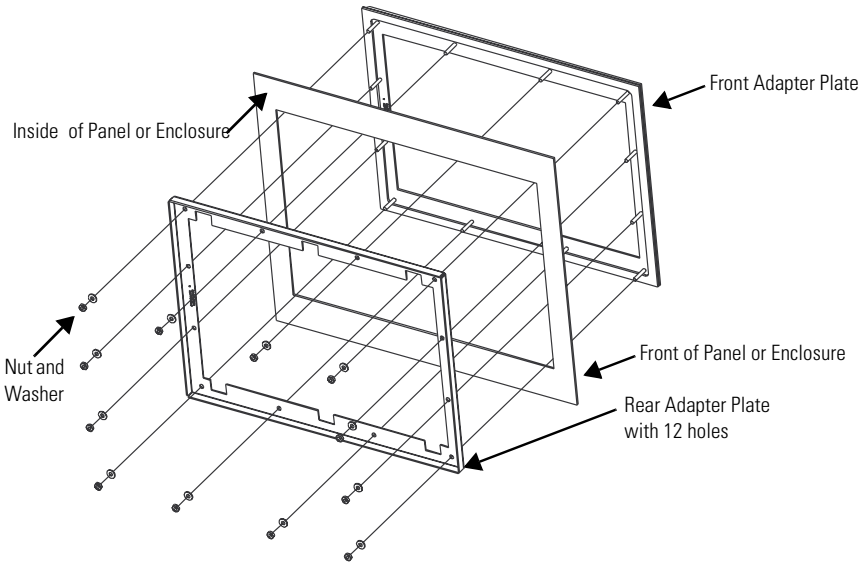

2. Mount the rear adapter plate to the front adapter plate studs from the back of the panel, flat side of rear adapter plate towards back of enclosure.

Use the 8, 10 or 12 nuts and flat washers to fasten the rear adapter plate to the studs.

3. Using the torque wrench, tighten the nuts to not more than 1.92 Nm (17 lb-in) to maintain a NEMA Type 4X rating.

Do not overtighten.

1000 Keypad Only

The studs on the adapter plate fit within the cutout of the terminal.

1. Place the adapter plate into the panel cutout until the sealing gasket material is firmly against the front of the panel.

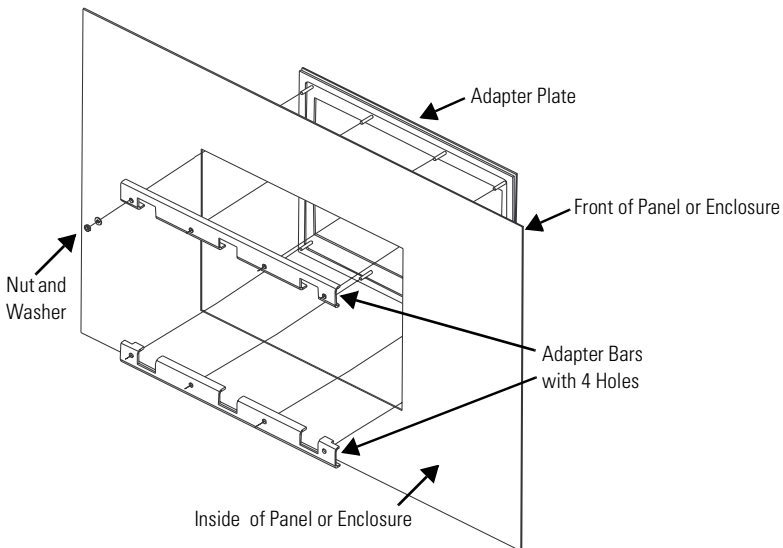

2. Mount the adapter bar to the adapter plate studs from the back of the panel, flat side of bar towards back of enclosure.

Use the 8 nuts and flat washers to fasten the adapter bar to the studs.

3. Using the torque wrench, tighten the nuts to no more than 1.13 Nm (10 lb-in) to maintain a NEMA Type 4X rating.

Do not overtighten.

Attach the Terminal to the Adapter Plate

1. Insert the new terminal into the front of the enclosure until the terminal gasket is flush with the adapter plate.
2. Install the mounting clips.

The number of clips varies depending on terminal type. The ends of the mounting clips slide into the slots on the terminal.

The illustration is a view from inside the enclosure. The top or bottom clips tighten directly to the adapter plate.

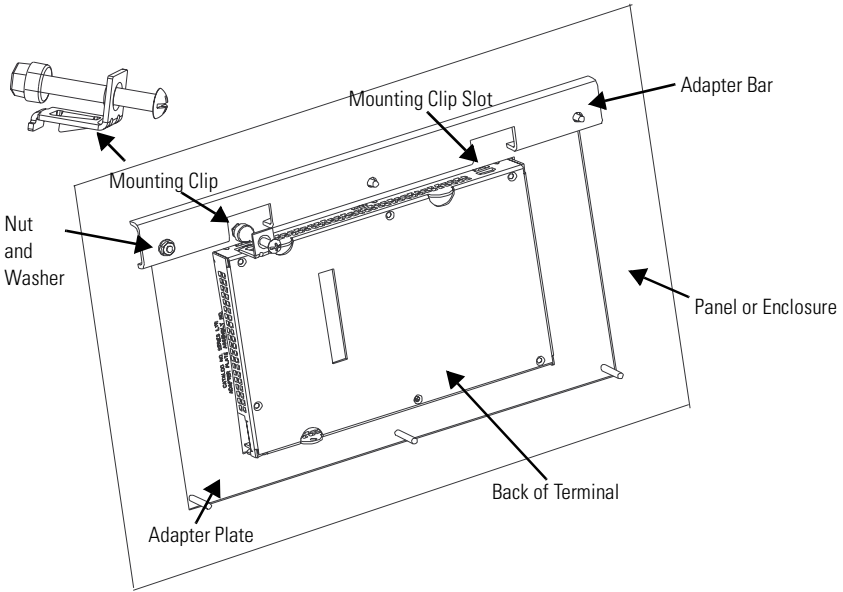

3. Tighten the screws on the mounting clips by hand until the gasket seal contacts the mounting surface uniformly.
4. Using the torque wrench, tighten the screws on the mounting clips to the specified torque rating provided in the installation instructions for the new terminal.

This is necessary to maintain a NEMA Type 4X rating. Do not overtighten.

ATTENTION



Tighten the mounting clips to the specified torque to provide a proper seal and to prevent potential damage to the terminal. Allen-Bradley assumes no responsibility for water or chemical damage to the product or other equipment within the enclosure because of improper installation.



Kit d'adaptation pour découpe de terminal PanelView Standard et PanelView « e »

Réf. 2711P-RAK7, 2711P-RAT7, 2711P-RAK10, 2711P-RAT10,
2711P-RAK12S, 2711P-RAT12S

Français

Pour les informations suivantes	Voir page
Description	10
Contenu du kit	10
Outils nécessaires	10
Déconnexion du terminal	11
Retrait du terminal existant	11
Fixation des plaques d'adaptation sur le panneau	12
Fixation du terminal à la plaque d'adaptation	13

Description

Ce document indique comment monter les équipements suivants dans une découpe existante prévue pour les PanelView Standard et les PanelView « e ».

- PanelView Plus 700 à 1250 ;
- PanelView Plus CE 700 à 1250.

Réf.	Ce nouveau terminal	S'insère dans une découpe prévue pour un
2711P-RAK7	PanelView Plus 700 à clavier PanelView Plus CE 700 à clavier	PanelView Standard 900 à clavier (2711-K9xxx)
2711P-RAT7	PanelView Plus 700 à dalle tactile PanelView Plus CE 700 à dalle tactile	PanelView Standard 900 à dalle tactile (2711-T9xxx)
2711P-RAK10	PanelView Plus 1000 à clavier PanelView Plus CE 1000 à clavier	PanelView Standard 1000 à clavier (2711-K10xxx) PanelView 1000e à clavier (2711E-K10xxx)
2711P-RAT10	PanelView Plus 1000 à dalle tactile PanelView Plus CE 1000 à dalle tactile	PanelView Standard 1000 à dalle tactile (2711-T10xxx) PanelView 1000e à dalle tactile (2711E-T10xxx)
2711P-RAK12S	PanelView Plus 1250 à clavier PanelView Plus CE 1250 à clavier	PanelView Standard 1400 à clavier (2711-K14xxx)
2711P-RAT12S	PanelView Plus 1250 à dalle tactile PanelView Plus CE 1250 à dalle tactile	PanelView Standard 1400 à dalle tactile (2711-T14xxx)

Contenu du kit

Le kit d'adaptation pour découpe contient les éléments suivants :

- plaques d'adaptation pour découpe avec joint d'étanchéité et espaceurs à roulement à billes ;
- barres d'adaptation pour plaques à 3 ou 4 trous ;
- 8, 10 ou 12 écrous n° 10-32 avec rondelles plates (selon le nombre de goujons de la plaque d'adaptation).

Outils nécessaires

Les outils suivants sont nécessaires pour monter les plaques d'adaptation :

- une clé à douille avec douille de 3/8 pouce ;
- un tournevis plat ou cruciforme ;
- une clé dynamométrique.

Déconnexion du terminal

1. Déconnectez l'alimentation à la source et débranchez le cordon d'alimentation du terminal PanelView.
 2. Déconnectez tous les câbles de communication du terminal.
-

ATTENTION



Assurez-vous que le cordon d'alimentation du terminal PanelView est déconnecté et que tous les autres câbles sont déconnectés du terminal.

Retrait du terminal existant

1. Retirez les colliers de fixation qui maintiennent le terminal sur le panneau.

TIP

Les colliers de fixation des PanelView Standard/ PanelView « e » sont différents des colliers des PanelView Plus. Rangez les colliers séparément pour éviter toute erreur par la suite.

2. Retirez le terminal du panneau.

Fixation des plaques d'adaptation sur le panneau

Les goujons de la plaque d'adaptation avant s'insèrent dans la découpe prévue pour le terminal.

1. Placez la plaque d'adaptation avant dans la découpe du panneau de manière à bien positionner le joint d'étanchéité contre l'avant du panneau.

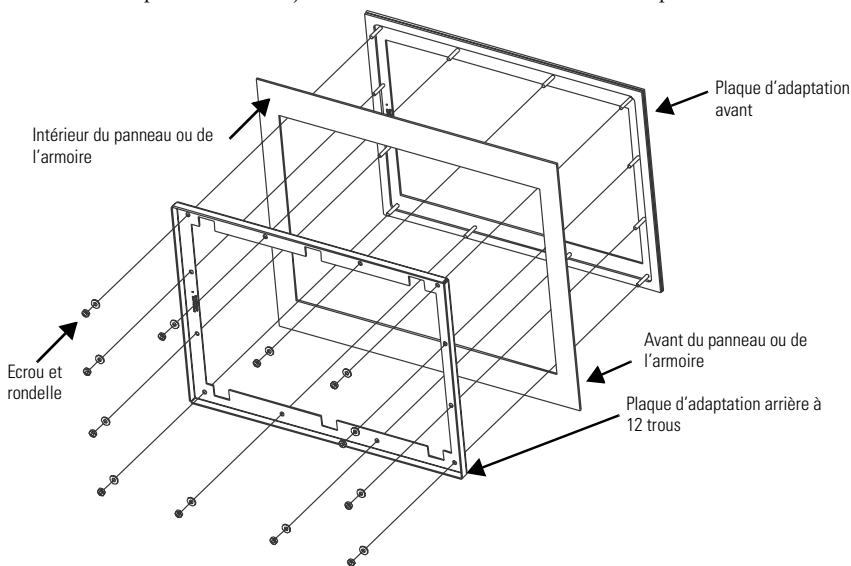

2. Montez la plaque d'adaptation arrière sur les goujons de la plaque avant, par l'arrière du panneau (le côté plat de la plaque d'adaptation arrière orienté vers l'arrière du panneau).

Fixez la plaque d'adaptation arrière sur les goujons à l'aide des écrous et des rondelles plates (8, 10 ou 12).

3. Utilisez la clé dynamométrique pour serrer les écrous avec un couple d'1,92 Nm maximum, afin de conserver une classification NEMA type 4X.

Veillez à ne pas trop les serrer.

Terminaux 1000 à clavier uniquement

Les goujons de la plaque d'adaptation s'insèrent dans la découpe prévue pour le terminal.

1. Placez la plaque d'adaptation dans la découpe du panneau de manière à bien positionner le joint d'étanchéité contre l'avant du panneau.

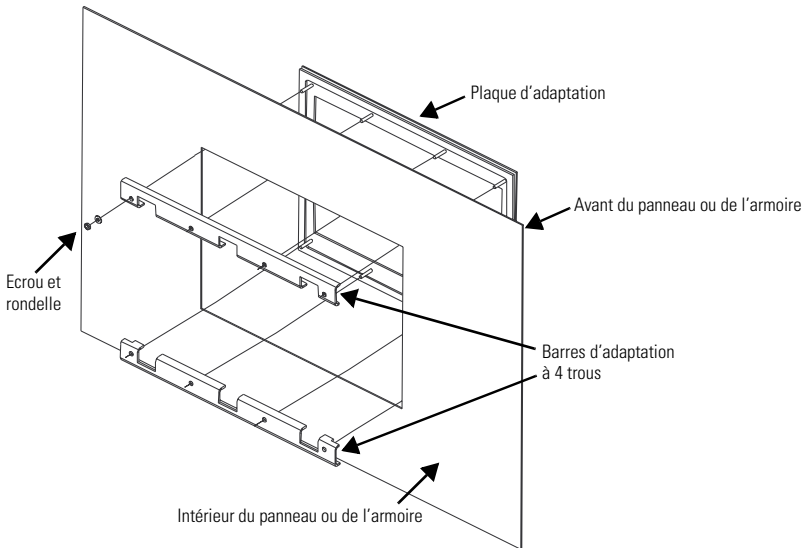

2. Fixez la barre d'adaptation sur les goujons de la plaque par l'arrière du panneau (le côté plat de la barre orienté vers l'arrière du panneau) à l'aide des 8 écrous et des 8 rondelles plates.
3. Utilisez la clé dynamométrique pour serrer les écrous avec un couple d'1,13 Nm maximum, afin de conserver une classification NEMA type 4X.
Veillez à ne pas trop les serrer.

Fixation du terminal à la plaque d'adaptation

1. Placez le nouveau terminal dans l'ouverture de manière à ce que son joint affleure la plaque d'adaptation.
2. Mettez les colliers de fixation en place.

Le nombre de colliers à utiliser varie suivant le type de terminal. Les extrémités des colliers s'insèrent dans les encoches situées sur le terminal.

L'illustration suivante est une vue de l'arrière du panneau ou de l'intérieur de l'armoire. Les colliers supérieurs et inférieurs se serrent directement sur la plaque d'adaptation.

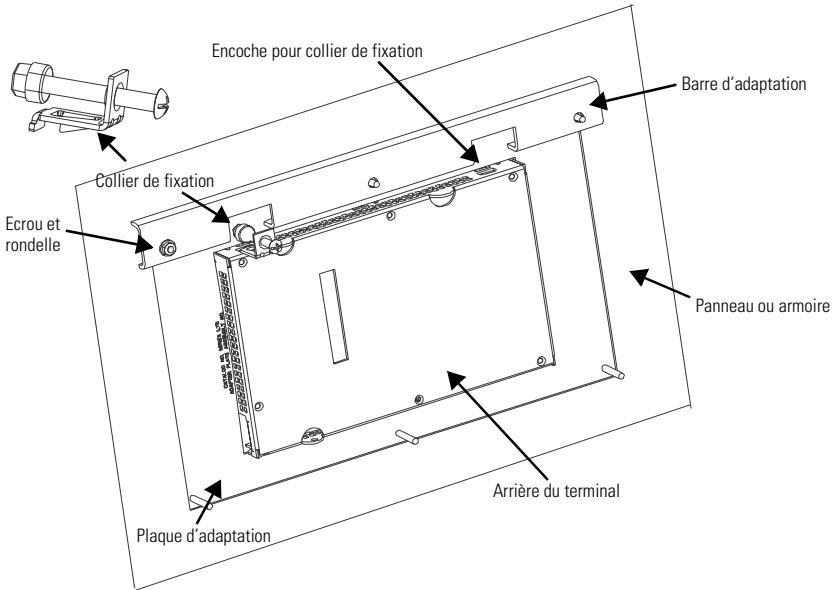

3. Serrez les vis des colliers de fixation à la main jusqu'à ce que le joint d'étanchéité soit positionné uniformément sur la surface de montage.
4. Utilisez la clé dynamométrique pour serrer les vis sur les colliers de fixation, en respectant le couple de serrage indiqué dans la notice d'installation du terminal.

Le couple de serrage doit être respecté pour conserver une classification NEMA type 4X. Veillez à ne pas trop les serrer.

ATTENTION



Serrez les colliers de fixation avec le couple de serrage qui convient pour obtenir une bonne étanchéité et éviter d'endommager le terminal.

Allen-Bradley ne saurait être tenu pour responsable des dégâts causés par une infiltration d'eau ou de produit chimique dans le terminal ou dans tout autre équipement présent dans l'armoire, suite à une installation incorrecte.



Adapter-Kit für Ausschnitte für Terminals des Typs PanelView Standard und PanelView „e“

Bestellnummern 2711P-RAK7, 2711P-RAT7, 2711P-RAK10, 2711P-RAT10, 2711P-RAK12S, 2711P-RAT12S

Deutsch

Thema	Seite
Beschreibung	15
Lieferumfang	16
Erforderliche Werkzeuge	16
Abklemmen des Terminals	16
Ausbau eines vorhandenen Terminals	17
Befestigen der Adapterplatten am Schaltschrank	17
Befestigen des Terminals an der Adapterplatte	20

Beschreibung

In dem vorliegenden Dokument wird der Einbau folgender Geräte in einem vorhandenen Ausschnitt für ein Terminal des Typs PanelView Standard und PanelView „e“ beschrieben.

- PanelView Plus 700-1250
- PanelView Plus CE 700-1250

Bestell-Nr.	Neues Terminal:	Vorhandener Ausschnitt für:
2711P-RAK7	PanelView Plus 700 Tastatur PanelView Plus CE 700 Tastatur	PanelView Standard 900 Tastatur (2711-K9xxx)
2711P-RAT7	PanelView Plus 700 Touchscreen PanelView Plus CE 700 Touchscreen	PanelView Standard 900 Touchscreen (2711-T9xxx)
2711P-RAK10	PanelView Plus 1000 Tastatur PanelView Plus CE 1000 Tastatur	PanelView Standard 1000 Tastatur (2711-K10xxx) PanelView 1000e Tastatur (2711E-K10xxx)
2711P-RAT10	PanelView Plus 1000 Touchscreen PanelView Plus CE 1000 Touchscreen	PanelView Standard 1000 Touchscreen (2711-T10xxx) PanelView 1000e Touchscreen (2711E-T10xxx)
2711P-RAK12S	PanelView Plus 1250 Tastatur PanelView Plus CE 1250 Tastatur	PanelView Standard 1400 Tastatur (2711-K14xxx)
2711P-RAT12S	PanelView Plus 1250 Touchscreen PanelView Plus CE 1250 Touchscreen	PanelView Standard 1400 Touchscreen (2711-T14xxx)

Lieferumfang

Das Ausschnittadapter-Kit enthält:

- Ausschnittadapterplatten mit Dichtung und Distanzblöcken mit Kugellager
- Adapterleisten für Platten mit 3 oder 4 Löchern
- 8, 10 oder 12 Muttern #10–32 mit Unterlegscheiben (je nach Anzahl der Stifte an der Adapterplatte)

Erforderliche Werkzeuge

Folgende Werkzeuge werden für die Installation benötigt:

- Steckschlüssel mit 3/8-Zoll-Einsatz
- Schlitz- oder Kreuzschlitz-Schraubendreher
- Drehmomentschlüssel für 1,92 Nm

Abklemmen des Terminals

1. Unterbrechen Sie die Stromversorgung an der Quelle und ziehen Sie das Netzkabel vom PanelView-Terminal ab.
 2. Ziehen Sie alle Kommunikationskabel vom Terminal ab.
-

ACHTUNG



Vergewissern Sie sich, dass das Netzkabel sowie alle anderen Kabel vom PanelView-Terminal abgezogen sind.

Ausbau eines vorhandenen Terminals

1. Entfernen Sie die Montageklammern, mit denen das Terminal im Schaltschrank gesichert ist.

TIPP

Die Montageklammern für Terminals des Typs PanelView Standard/PanelView „e“ unterscheiden sich von den Klammern für Terminals des Typs PanelView Plus. Zur Vermeidung von Verwechslungen sollten die Montageklammern daher separat aufbewahrt werden.

2. Ziehen Sie das vorhandene Terminal aus dem Schaltschrank.

Befestigen der Adapterplatten am Schaltschrank

Die Stifte auf der vorderen Adapterplatte passen in den Ausschnitt des vorhandenen Terminals.

1. Setzen Sie die vordere Adapterplatte auf den Schaltschrankschnitt auf, sodass die Dichtung gleichmäßig an der Vorderseite des Schaltschranks anliegt.

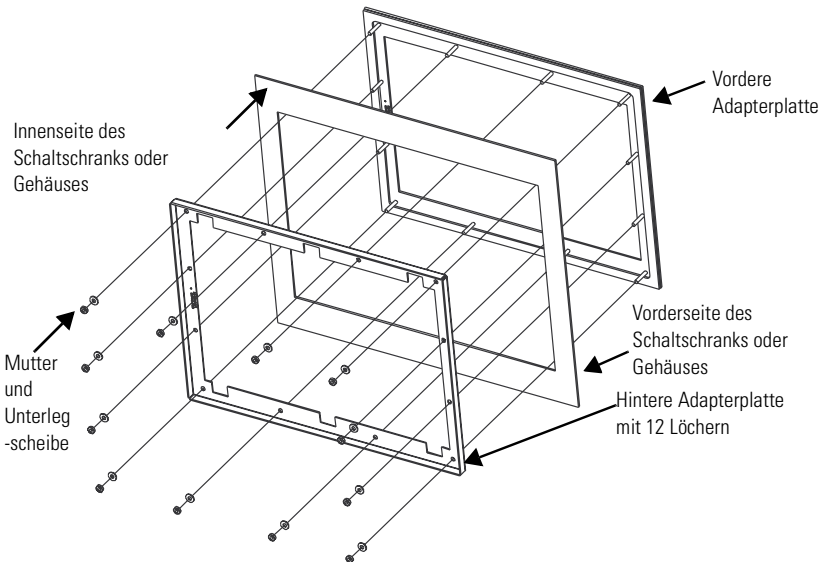

2. Befestigen Sie die hintere Adapterplatte von der Rückseite des Schaltschranks her an den Stiften der vorderen Adapterplatte; dabei muss die flache Seite der hinteren Adapterplatte zur Rückwand des Gehäuses ausgerichtet sein.

Befestigen Sie die hintere Adapterplatte unter Verwendung der (8, 10 oder 12) Muttern und Unterlegscheiben an den Stiften.

3. Ziehen Sie die Muttern mit Hilfe des Drehmomentschlüssels bis zu einem maximalen Drehmoment von 1,92 Nm an; dies ist das für die NEMA-Kategorie 4X vorgesehene Drehmoment.

Ziehen Sie die Schrauben nicht zu fest an.

Nur Tastatur 1000

Die Stifte auf der Adapterplatte passen in den Ausschnitt des vorhandenen Terminals.

1. Setzen Sie die Adapterplatte auf den Schaltschrankausschnitt auf, sodass die Dichtung gleichmäßig an der Vorderseite des Schaltschranks anliegt.

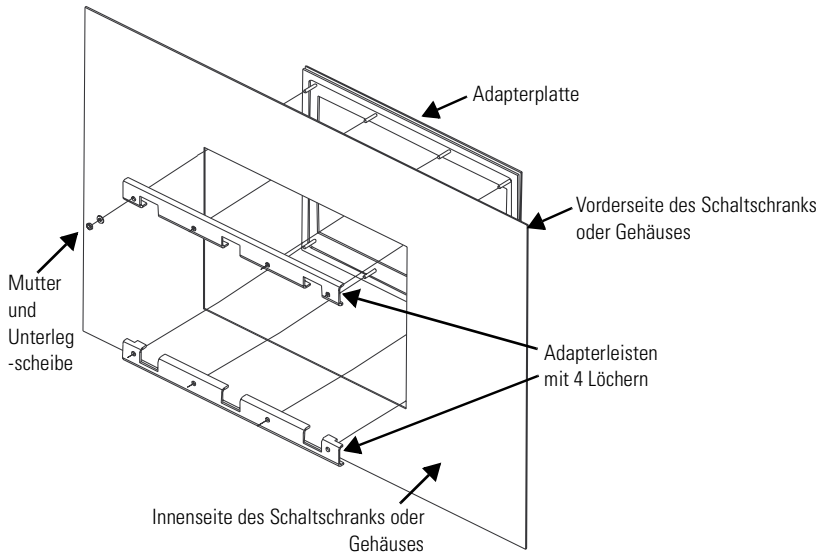

2. Befestigen Sie die Adapterleiste von der Rückseite des Schaltschranks her an den Stiften der Adapterplatte; dabei muss die flache Seite der Adapterleiste zur Rückwand des Gehäuses ausgerichtet sein.

Befestigen Sie die Adapterleiste unter Verwendung der acht Muttern und Unterlegscheiben an den Stiften.

3. Ziehen Sie die Muttern mit Hilfe des Drehmomentschlüssels bis zu einem maximalen Drehmoment von 1,13 Nm an; dies ist das für die NEMA-Kategorie 4X vorgesehene Drehmoment.

Ziehen Sie die Schrauben nicht zu fest an.

Befestigen des Terminals an der Adapterplatte

1. Setzen Sie das neue Terminal an der Vorderseite des Gehäuse an, bis die Dichtung des Terminals bündig mit der Adapterplatte ist.

2. Bringen Sie die Montageklammern an.

Die Anzahl der Klammern variiert je nach Terminaltyp. Die Enden der Klammern lassen sich in die Schlitzte am Terminal schieben.

Die nachfolgende Abbildung zeigt die Innenansicht des Gehäuses. Die oberen und die unteren Montageklammern sind direkt mit der Adapterplatte verbunden.

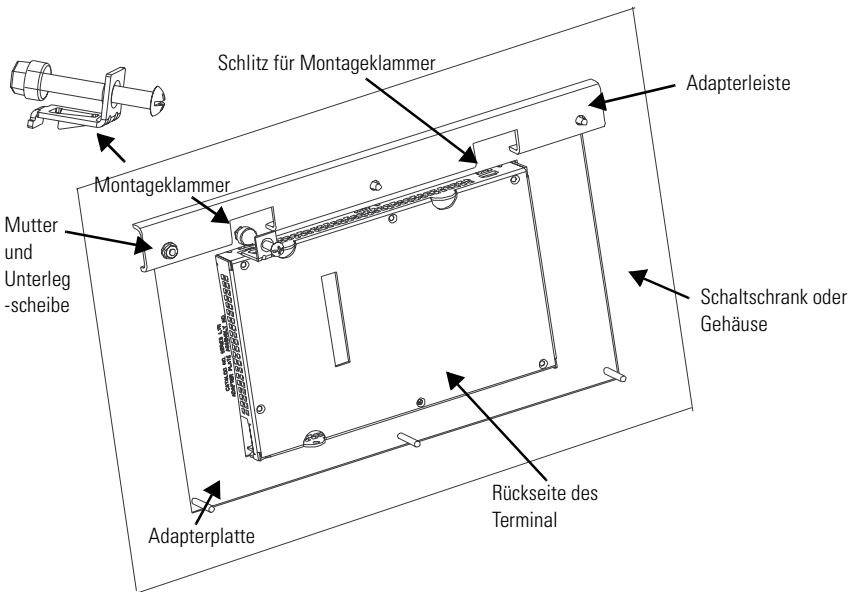

3. Ziehen Sie die Schrauben der Montageklammern von Hand an, bis die Dichtung die Montagefläche überall gleichmäßig berührt.

4. Ziehen Sie die Schrauben der Montageklammern mit Hilfe des Drehmomentschlüssels bis zu dem Drehmoment an, das in der Installationsanleitung des neuen Terminals angegeben ist.

Dies ist für die Einhaltung der Anforderungen gemäß NEMA-Kategorie 4X erforderlich. Ziehen Sie die Schrauben nicht zu fest an.

ACHTUNG



Ziehen Sie die Schrauben der Montageklammern mit dem korrekten Drehmoment an, um eine ordnungsgemäße Dichtung zu gewährleisten und eine mögliche Beschädigung des Terminals zu vermeiden. Rockwell Automation übernimmt keine Haftung für Schäden, die durch Wasser oder Chemikalien am Terminal oder an anderen Geräten innerhalb des Gehäuses entstehen und auf eine unsachgemäße Installation zurückzuführen sind.



Juego adaptador para cortes de terminal PanelView Estándar y PanelView “e”

Números de catálogo 2711P-RAK7, 2711P-RAT7, 2711P-RAK10,
2711P-RAT10, 2711P-RAK12S, 2711P-RAT12S

Español

Para consultar	Vea la página
Descripción	21
Contenido del paquete	22
Herramientas requeridas	22
Desconecte el terminal	22
Extraiga el terminal existente	23
Acople las placas adaptadoras al panel	23
Acople el terminal a la placa adaptadora	25

Descripción

Este documento proporciona instrucciones para montar los siguientes dispositivos en cortes existentes para terminal PanelView Estándar y PanelView “e”.

- PanelView Plus 700-1250
- PanelView Plus CE 700-1250

No. de cat.	Este nuevo terminal:	Cabe en este corte existente para:
2711P-RAK7	Teclado PanelView Plus 700 Teclado PanelView Plus CE 700	Teclado PanelView Estándar 900 (2711-K9xxx)
2711P-RAT7	Pantalla táctil PanelView Plus 700 Pantalla táctil PanelView Plus CE 700	Pantalla táctil PanelView Estándar 900 (2711-T9xxx)
2711P-RAK10	Teclado PanelView Plus 1000 Teclado PanelView Plus CE 1000	Teclado PanelView Estándar 1000 (2711-K10xxx) Teclado PanelView 1000e (2711E-K10xxx)
2711P-RAT10	Pantalla táctil PanelView Plus 1000 Pantalla táctil PanelView Plus CE 1000	Pantalla táctil PanelView Estándar 1000 (2711-T10xxx) Pantalla táctil PanelView 1000e (2711E-T10xxx)
2711P-RAK12S	Teclado PanelView Plus 1250 Teclado PanelView Plus CE 1250	Teclado PanelView Estándar 1400 (2711-K14xxx)
2711P-RAT12S	Pantalla táctil PanelView Plus 1250 Pantalla táctil PanelView Plus CE 1250	Pantalla táctil PanelView Estándar 1400 (2711-T14xxx)

Contenido del paquete

El juego adaptador de corte incluye:

- placas adaptadoras de corte con empaquetadura y separadores de cojinetes de bolas
- barras adaptadoras para placas con 3 ó 4 orificios
- 8, 10 ó 12 tuercas #10-32 con arandelas planas (dependiendo del número de pernos de la placa adaptadora)

Herramientas requeridas

Se requieren las siguientes herramientas para la instalación:

- llave de cubo con casquillo de 3/8 pulg.
- destornillador plano o Phillips
- llave dinamométrica con capacidad de 17 pulg.-libras

Desconecte el terminal

1. Desconecte la alimentación en la fuente y extraiga el cable de alimentación del terminal PanelView.
 2. Desconecte todos los cables de alimentación del terminal.
-

ATENCIÓN



Asegúrese de que el cable de alimentación del terminal PanelView esté desconectado y que todos los cables hayan sido desconectados del terminal.

Extraiga el terminal existente

1. Quite las abrazaderas de montaje que fijan el terminal al panel.

TIP

Las abrazaderas de montaje del PanelView Estándar/PanelView "e" son diferentes de las abrazaderas de montaje del PanelView Plus. Guarde las abrazaderas de montaje por separado para evitar confusión posteriormente.

2. Deslice el terminal existente fuera del panel.

Acople las placas adaptadoras al panel

Los pernos ubicados en la placa adaptadora frontal encajan dentro del corte del terminal.

1. Coloque la placa adaptadora frontal dentro del corte de panel hasta que el material de la empaquetadura selladora esté ubicado firmemente contra la parte frontal del panel.

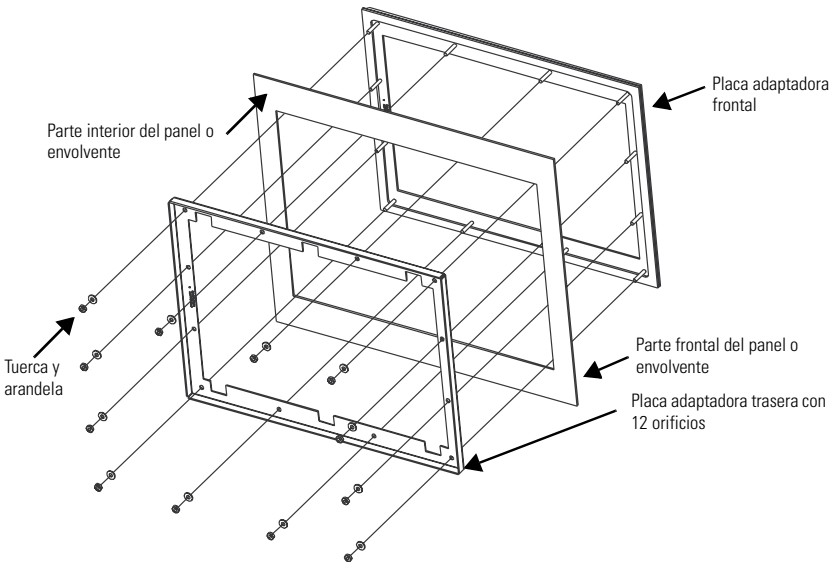

2. Monte la placa adaptadora trasera en los pernos de la placa adaptadora frontal desde la parte posterior del panel (el lado plano de la placa adaptadora trasera hacia la parte posterior del envoltorio).

Con las (8, 10 ó 12) tuercas y arandelas planas, fije la placa adaptadora trasera a los pernos.

3. Con la llave dinamométrica, apriete las tuercas a un par no mayor de 1,92 Nm (17 pulg.-lbs) para mantener la clasificación NEMA Tipo 4X.

No apriete demasiado.

Teclado 1000 solamente

Los pernos ubicados en la placa adaptadora encajan dentro del corte del terminal.

1. Coloque la placa adaptadora dentro del corte de panel hasta que el material de la empaquetadura selladora esté ubicada firmemente contra la parte frontal del panel.

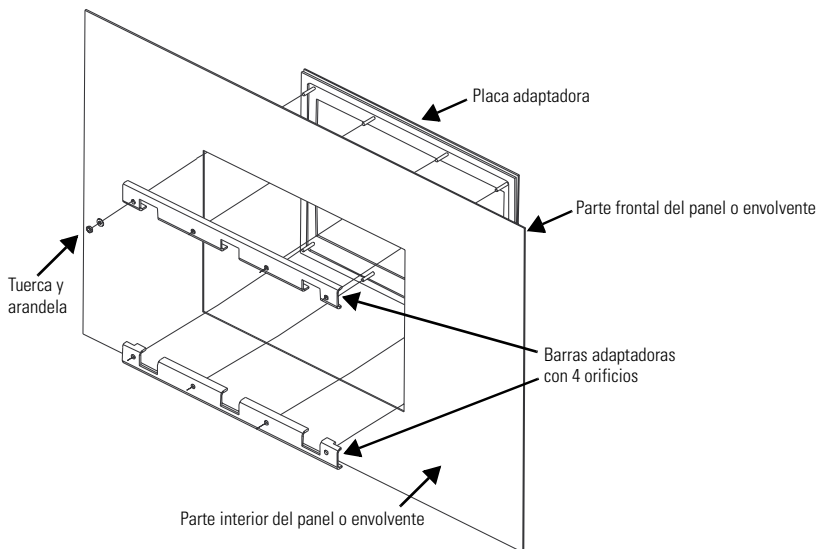

2. Monte la barra adaptadora en los pernos de la placa adaptadora desde la parte posterior del panel (el lado plano de la barra hacia la parte posterior del envoltente).

Con las (8) tuercas y arandelas planas, fije la barra adaptadora en los pernos.

3. Con la llave dinamométrica, apriete las tuercas a un par no mayor de 1,13 Nm (10 pulg.-lbs) para mantener la clasificación NEMA Tipo 4X.

No apriete demasiado.

Acople el terminal a la placa adaptadora

1. Inserte el nuevo terminal en la parte frontal del envoltente hasta que la empaquetadura del terminal quede al ras con la placa adaptadora.
2. Instale las abrazaderas de montaje.

El número de abrazaderas varía dependiendo del tipo de terminal. Los extremos de las abrazaderas se deslizan dentro de las ranuras en el terminal.

La siguiente ilustración es una vista del interior del envoltorio. Las abrazaderas superiores o inferiores se aprietan directamente en la placa adaptadora.

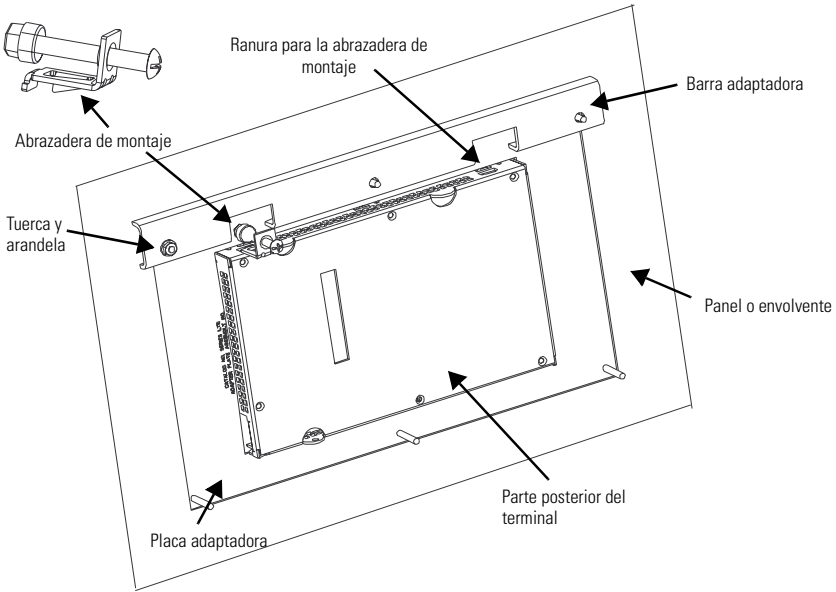

3. Apriete manualmente los tornillos de las abrazaderas de montaje hasta que el sello de la empaquetadura haga contacto con la superficie de montaje de manera uniforme.
4. Con la llave dinamométrica, apriete los tornillos de las abrazaderas de montaje según la especificación de par apropiada proporcionada en las instrucciones de instalación del nuevo terminal.

Esto es necesario para mantener la clasificación NEMA Tipo 4X. No apriete demasiado.

ATENCIÓN



Apriete las abrazaderas de montaje según la especificación de par indicada para proporcionar un sello adecuado y para evitar un daño potencial al dispositivo. Allen-Bradley no asumirá responsabilidad alguna por daños ocasionados por agua o productos químicos al terminal u otros equipos dentro del



Kit adattatore per finestrate dei terminali PanelView standard e PanelView "e"

Numero di catalogo 2711P-RAK7, 2711P-RAT7, 2711P-RAK10,
2711P-RAT10, 2711P-RAK12S, 2711P-RAT12S

Italiano

Per:	Vedere pagina
Descrizione	27
Contenuto dell'imballaggio	28
Attrezzi necessari	28
Scollegare il terminale	28
Rimuovere il terminale esistente	29
Fissare le piastre adattatrici al pannello	29
Fissare il terminale alla cornice adattatrice	32

Descrizione

Questo documento contiene le istruzioni su come montare i seguenti dispositivi nelle aperture esistenti per terminali PanelView standard e PanelView "e".

- PanelView Plus 700-1250
- PanelView Plus CE 700-1250

Num. di cat.	Questo nuovo terminale:	Si adatta alla finestatura esistente di:
2711P-RAK7	PanelView Plus 700 con Tastierino PanelView Plus CE 700 con Tastierino	PanelView Standard 900 con Tastierino(2711-K9xxx)
2711P-RAT7	PanelView Plus 700 Touchscreen PanelView Plus CE 700 Touchscreen	PanelView Standard 900 Touchscreen (2711-T9xxx)
2711P-RAK10	PanelView Plus 1000 con Tastierino PanelView Plus CE 1000 con Tastierino	PanelView Standard 1000 con con Tastierino(2711-K10xxx) PanelView 1000e con Tastierino(2711E-K10xxx)
2711P-RAT10	PanelView Plus 1000 Touchscreen PanelView Plus CE 1000 Touchscreen	PanelView Standard 1000 Touchscreen (2711-T10xxx) PanelView 1000e Touchscreen (2711E-T10xxx)
2711P-RAK12S	PanelView Plus 1250 con con Tastierino PanelView Plus CE 1250 con Tastierino	PanelView Standard 1400 con Tastierino(2711-K14xxx)
2711P-RAT12S	PanelView Plus 1250 Touchscreen PanelView Plus CE 1250 Touchscreen	PanelView Standard 1400 Touchscreen (2711-T14xxx)

Contenuto dell'imballaggio

Il kit adattatore per la finestatura contiene:

- cornice adattatrice per l'apertura con guarnizione e distanziatori
- barre adattatrici per piastre con 3 o 4 fori
- 8 , 10 o 12 dadi #10-32 con rondelle piatte (in base al numero di perni della cornice adattatrice)

Attrezzi necessari

Per l'installazione sono richiesti i seguenti attrezzi:

- operatore per chiave a bussola con chiave da 3/8 di pollice
- cacciavite a lama piatta o a croce
- chiave dinamometrica da 17 pollici-libbra

Scollegare il terminale

1. Scollegare l'alimentazione e rimuovere il cavo di alimentazione dal terminale PanelView.
 2. Scollegare tutti i cavi di comunicazione dal terminale.
-

AVVERTENZA



Assicurarsi che il cavo di alimentazione del terminale PanelView sia scollegato e che tutti i cavi del terminale siano stati scollegati.

Rimuovere il terminale esistente

1. Rimuovere le clip di montaggio che fissare il terminale al pannello.

TIP

Le clip di montaggio del terminal PanelView Standard/PanelView "e" sono diverse da quelle del terminale PanelView Plus. Conservare separatamente le clip di montaggio per evitare confusione successivamente.

2. Estrarre il terminale esistente dal pannello.

Fissare le piastre adattatrici al pannello

I perni posti sulla cornice adattatrice anteriore si inseriscono all'interno dell'apertura del terminale.

1. Inserire la cornice adattatrice anteriore nell'apertura del pannello fino a quando la guarnizione di tenuta non tocca il pannello.

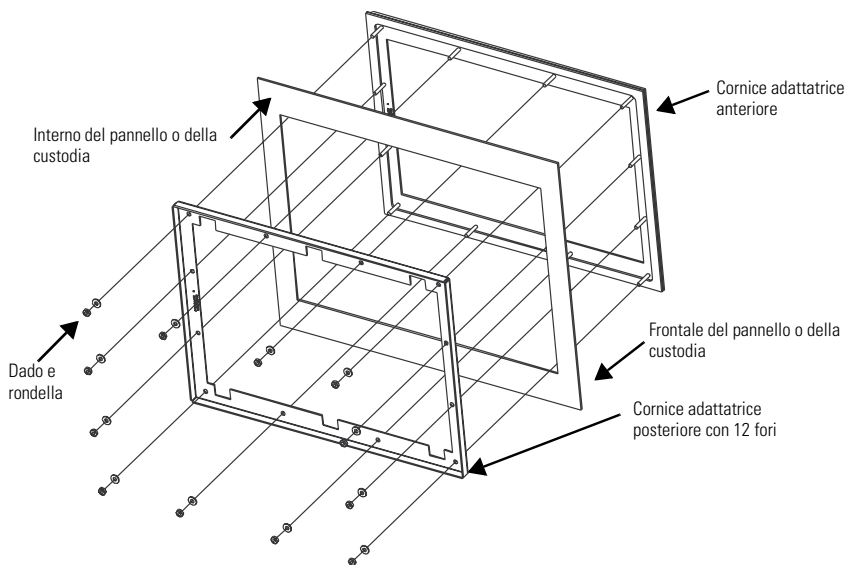

2. Da dietro il pannello (con il lato liscio della cornice posteriore rivolto verso l'interno della custodia), montare la cornice adattatrice posteriore sui perni della cornice anteriore.

Stringere la cornice adattatrice posteriore sui perni, utilizzando i dadi e le rondelle (8, 10 o 12).

3. Utilizzando la chiave dinamometrica, stringere i dadi con una coppia non maggiore di 1.92 Nm (17 poll.-lb) al fine di mantenere il grado di protezione NEMA Tipo 4X.

Non stringere troppo.

Solo 1000 con tastierino numerico

I perni presenti sulla cornice adattatrice entrano all'interno della finestratura del terminale.

1. Inserire la cornice adattatrice nella finestratura del pannello fino a quando la guarnizione di tenuta non tocca con il frontale del pannello.

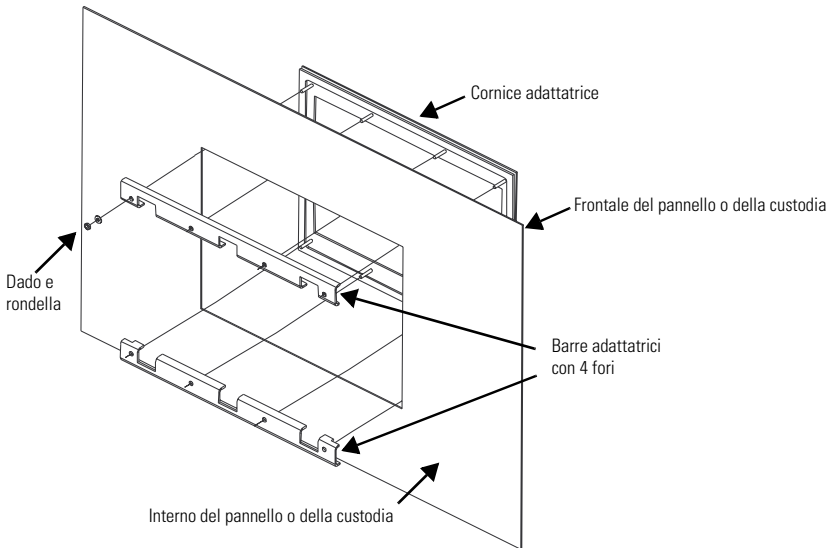

2. Da dietro il pannello (con il lato liscio della barra rivolto verso l'interno della custodia), montare la barra adattatrice sui perni della cornice anteriore.

Stringere la barra adattatrice posteriore sui perni, utilizzando i dadi e le rondelle (8).

3. Utilizzando la chiave dinamometrica, stringere i dadi con una coppia maggiore di 1.13 Nm (10 poll.-lb) al fine di mantenere il grado di protezione NEMA Tipo 4X.

Non stringere troppo.

Fissare il terminale alla cornice adattatrice

1. Inserire il nuovo terminale nel frontale della custodia fino a quando la guarnizione del terminale risulta allineata con la cornice adattatrice.
2. Installare le clip di montaggio. Il numero delle clip varia a seconda del tipo di terminale. Le estremità delle clip di montaggio si inseriscono nei fori del terminale.

La seguente figura si riferisce alla vista dall'interno della custodia. Le clip superiori o inferiori si inseriscono direttamente sulla cornice adattatrice.

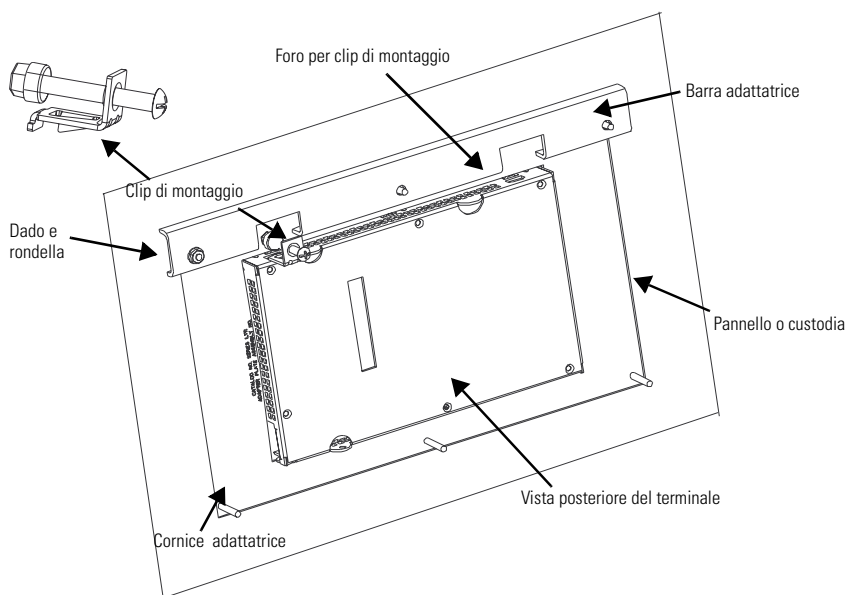

3. Stringere a mano le viti delle clip di montaggio fino a quando la guarnizione aderisce uniformemente alla superficie di montaggio.
4. Utilizzando la chiave dinamometrica, stringere le viti delle clip di montaggio in base ai valori di coppia forniti nelle istruzioni per l'installazione del nuovo terminale.

Ciò è necessario per mantenere il grado di protezione NEMA Tipo 4X. Non stringere troppo.

AVVERTENZA



Avvitare le clip di montaggio con una coppia di serraggio adeguata per fornire una corretta tenuta e per evitare potenziali danni al terminale. Allen-Bradley non si assume alcuna responsabilità per danni al terminale o ad altre apparecchiature poste all'interno della custodia provocati da acqua o agenti chimici e riconducibili ad una errata installazione.



Kit de Adaptador para Cortes dos Terminais PanelView Standard e PanelView “e”

Código de Catálogo 2711P-RAK7, 2711P-RAT7, 2711P-RAK10,
2711P-RAT10, 2711P-RAK12S, 2711P-RAT12S

Português

Para	Consulte a página
Descrição	33
Conteúdo do Pacote	34
Ferramentas Necessárias	34
Desconexão do Terminal	34
Remoção do Terminal Existente	35
Ligação das Placas do Adaptador ao Painel	35
Fixação do Terminal à Placa do Adaptador	37

Descrição

Este documento fornece instruções sobre como montar os seguintes dispositivos em cortes dos terminais PanelView Standard e PanelView “e” existentes.

- PanelView Plus 700-1250
- PanelView Plus CE 700-1250

Cód. Cat.	Este Novo Terminal:	Encaixa no Corte Existente:
2711P-RAK7	PanelView Plus 700 com Teclado PanelView Plus CE 700 com Teclado	PanelView Standard 900 com Teclado (2711-K9xxx)
2711P-RAT7	PanelView Plus 700 com Tela Touch PanelView Plus CE 700 com Tela Touch	PanelView Standard 900 com Tela Touch (2711-T9xxx)
2711P-RAK10	PanelView Plus 1000 com Teclado PanelView Plus CE 1000 com Teclado	PanelView Standard 1000 com Teclado (2711-K9xxx) PanelView 1000e com Teclado (2711E-K14xxx)
2711P-RAT10	PanelView Plus 1000 com Tela Touch PanelView Plus CE 1000 com Tela Touch	PanelView Standard 1000 com Tela Touch (2711-T9xxx) PanelView 1000e com Tela Touch (2711E-K14xxx)
2711P-RAK12S	PanelView Plus 1250 com Teclado PanelView Plus CE 1250 com Teclado	PanelView Standard 1400 com Teclado (2711-K9xxx)
2711P-RAT12S	PanelView Plus 1250 com Tela Touch PanelView Plus CE 1250 com Tela Touch	PanelView Standard 1400 com Tela Touch (2711-T9xxx)

Conteúdo do Pacote

O Kit de Adaptador de Corte inclui:

- placas do adaptador de corte com junta e espaçador de rolamento de esferas
- barras do adaptador para placas com 3 ou 4 furos
- porcas de 8, 10 ou 12 #10-32 com arruelas chatas (dependendo do número de pinos na placa do adaptador)

Ferramentas Necessárias

As seguintes ferramentas são necessárias para a instalação:

- chave para soquete de 3/8 pol.
- chave de fenda ou Phillips
- chave de torque com capacidade de 17 pol/lbs

Desconexão do Terminal

1. Desconecte a alimentação na fonte e remova o fio de alimentação do terminal PanelView.
 2. Desconecte todos os cabos de comunicação do terminal.
-

ADVERTÊNCIA



Certifique-se de que o fio de alimentação do terminal PanelView esteja desconectado e que todos os cabos tenham sido desconectados do terminal.

Remoção do Terminal Existente

1. Remova os clips de montagem que prendem o terminal no painel.

TIP

Os clips de montagem do PanelView Standard/PanelView "e" são diferentes dos clips do PanelView Plus. Armazene os clips de montagem separadamente para evitar confusões futuras.

2. Deslize o terminal existente para fora do painel.

Ligação das Placas do Adaptador ao Painel

Os pinos na placa frontal do adaptador se encaixam dentro do corte do terminal.

1. Posicione a placa frontal do adaptador no painel de corte, até que o material da junta de vedação esteja firmemente encaixada na parte frontal do painel.

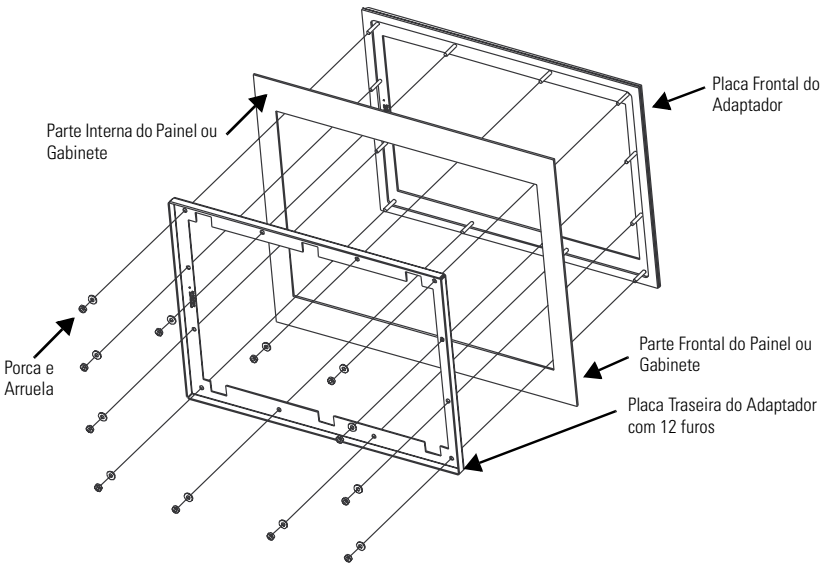

2. Encaixe a placa traseira do adaptador aos pinos da placa frontal do adaptador a partir da parte posterior do painel (lado chato da placa traseira do adaptador em direção à parte traseira do gabinete).
3. Ao utilizar as porcas (8, 10 ou 12) e arruelas chatas, fixe a placa traseira do adaptador aos pinos.
4. Ao utilizar a chave de torque, aperte as porcas não mais que 1,92 Nm (17 pol-lbs) para manter uma classificação NEMA Tipo 4X.
Não aperte demais.

Somente Teclado 1000

Os pinos na placa de adaptador se encaixam dentro do corte do terminal.

1. Posicione a placa do adaptador no corte do painel, até que o material de junta de vedação esteja firmemente encaixada na parte frontal do painel.

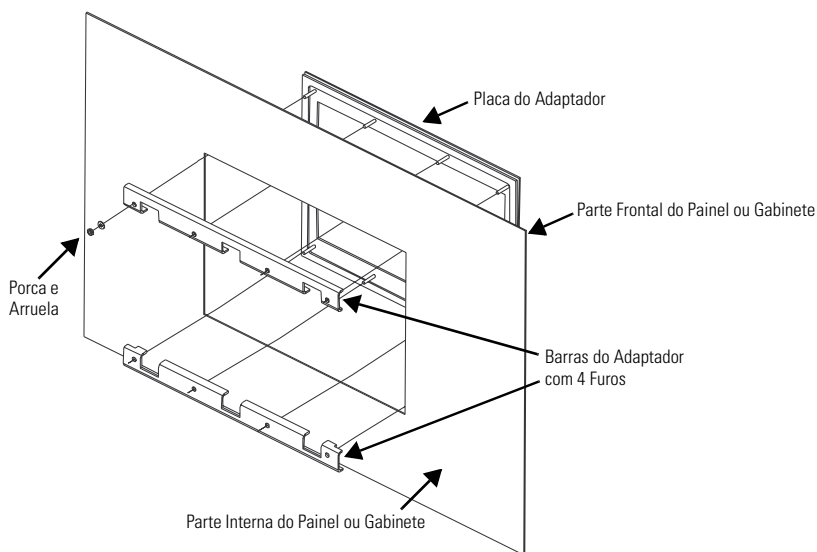

2. Encaixe a barra do adaptador aos pinos da placa do adaptador, a partir da parte posterior do painel (lado chato da barra em direção à parte traseira do gabinete).

Ao utilizar as porcas (8) e arruelas chatas, fixe a barra do adaptador nos pinos.

3. Ao utilizar a chave de torque, aperte as porcas não mais que 1,13 Nm (10 pol-lbs) para manter uma classificação NEMA Tipo 4X.

Não aperte demais.

Fixação do Terminal à Placa do Adaptador

1. Insira o novo terminal na parte frontal do gabinete até que a junta do terminal esteja alinhada com a placa do adaptador.
2. Instale os clips de montagem.

O número de clips varia de acordo com o tipo de terminal. As extremidades dos clips deslizam para dentro das ranhuras no terminal.

A seguinte ilustração é uma visualização da parte interna do gabinete. Os clips superiores e inferiores são fixados diretamente à placa do adaptador.

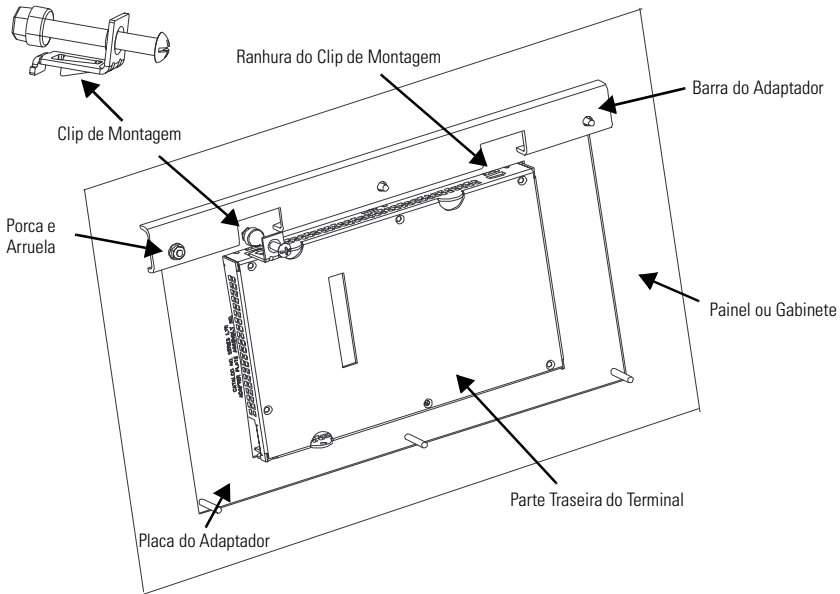

3. Aperte manualmente os parafusos nos clips de montagem, até que a junta de vedação entre uniformemente em contato com a superfície de montagem.
4. Ao utilizar a chave de torque, aperte os parafusos nos clips de montagem, de acordo com a classificação adequada de torque, fornecida nas instruções de instalação para o novo terminal.

Este procedimento é necessário para manter uma classificação NEMA Tipo 4X. Não aperte demais.

ADVERTÊNCIA



Aperte os clips de montagem de acordo com a classificação de torque correta para criar uma vedação adequada e evitar possíveis danos ao terminal. A Allen-Bradley não se responsabiliza por danos causados por agentes químicos ou água ao terminal ou outros equipamentos dentro do gabinete devido a uma instalação inadequada.

Rockwell Automation Support

Rockwell Automation provides technical information on the Web to assist you in using its products. At <http://support.rockwellautomation.com>, you can find technical manuals, a knowledge base of FAQs, technical and application notes, sample code and links to software service packs, and a MySupport feature that you can customize to make the best use of these tools.

For an additional level of technical phone support for installation, configuration, and troubleshooting, we offer TechConnect Support programs. For more information, contact your local distributor or Rockwell Automation representative, or visit <http://support.rockwellautomation.com>.

Installation Assistance

If you experience a problem with a hardware module within the first 24 hours of installation, please review the information that's contained in this manual. You can also contact a special Customer Support number for initial help in getting your module up and running.

United States	1.440.646.3223 Monday – Friday, 8am – 5pm EST
Outside United States	Please contact your local Rockwell Automation representative for any technical support issues.

New Product Satisfaction Return

Rockwell tests all of its products to ensure that they are fully operational when shipped from the manufacturing facility. However, if your product is not functioning, it may need to be returned.

United States	Contact your distributor. You must provide a Customer Support case number (see phone number above to obtain one) to your distributor in order to complete the return process.
Outside United States	Please contact your local Rockwell Automation representative for return procedure.

Allen-Bradley, PanelView, TechConnect, and Rockwell Automation are trademarks of Rockwell Automation, Inc.

Trademarks not belonging to Rockwell Inc. are property of their respective companies.

www.rockwellautomation.com

Power, Control and Information Solutions Headquarters

Americas: Rockwell Automation, 1201 South Second Street, Milwaukee, WI 53204-2496 USA, Tel: (1) 414.382.2000, Fax: (1) 414.382.4444
Europe/Middle East/Africa: Rockwell Automation, Vorstlaan/Boulevard du Souverain 36, 1170 Brussels, Belgium, Tel: (32) 2 663 0600, Fax: (32) 2 663 0640
Asia Pacific: Rockwell Automation, Level 14, Core F, Cyberport 3, 100 Cyberport Road, Hong Kong, Tel: (852) 2887 4788, Fax: (852) 2508 1846

Publication 2711P-IN010C-MU-P - March 2007

PN 41061-305-01(3)

Supersedes Publication 2711P-IN010B-MU-P - April 2003

Copyright © 2007 Rockwell Automation, Inc. All rights reserved. Printed in the U.S.A.