

PanelView 550 Terminal Function Key Legend Kit

Catalog Number 2711-NF1

Topic	Page
English	3
Français	5
Deutsch	7
Italiano	9
Español	11

Important User Information

Solid state equipment has operational characteristics differing from those of electromechanical equipment. Safety Guidelines for the Application, Installation and Maintenance of Solid State Controls (Publication SGI-1.1 available from your local Rockwell Automation sales office or online at <http://literature.rockwellautomation.com>) describes some important differences between solid state equipment and hard-wired electromechanical devices. Because of this difference, and also because of the wide variety of uses for solid state equipment, all persons responsible for applying this equipment must satisfy themselves that each intended application of this equipment is acceptable.





In no event will Rockwell Automation, Inc. be responsible or liable for indirect or consequential damages resulting from the use or application of this equipment.

The examples and diagrams in this manual are included solely for illustrative purposes. Because of the many variables and requirements associated with any particular installation, Rockwell Automation, Inc. cannot assume responsibility or liability for actual use based on the examples and diagrams.

No patent liability is assumed by Rockwell Automation, Inc. with respect to use of information, circuits, equipment, or software described in this manual.

Reproduction of the contents of this manual, in whole or in part, without written permission of Rockwell Automation, Inc., is prohibited.

Throughout this manual, when necessary, we use notes to make you aware of safety considerations.

<p>WARNING</p> 	<p>Identifies information about practices or circumstances that can cause an explosion in a hazardous environment, which may lead to personal injury or death, property damage, or economic loss.</p>
<p>IMPORTANT</p>	<p>Identifies information that is critical for successful application and understanding of the product.</p>
<p>ATTENTION</p> 	<p>Identifies information about practices or circumstances that can lead to personal injury or death, property damage, or economic loss. Attentions help you identify a hazard, avoid a hazard and recognize the consequences.</p>
<p>SHOCK HAZARD</p> 	<p>Labels may be on or inside the equipment (for example, drive or motor) to alert people that dangerous voltage may be present.</p>
<p>BURN HAZARD</p> 	<p>Labels may be on or inside the equipment (for example, drive or motor) to alert people that surfaces may reach dangerous temperatures.</p>

PanelView 550 Terminal Function Key Legend Kit

Catalog Number 2711-NF1

English

About the Function Key Legend Kit

The Function Key Legend Kit contains five inserts. One side of the inserts are preprinted with the function key legends F1...F10. The other side of each insert is blank and has text areas for 2 function key labels. Use the blank side of the inserts to label the function keys for a specific application.

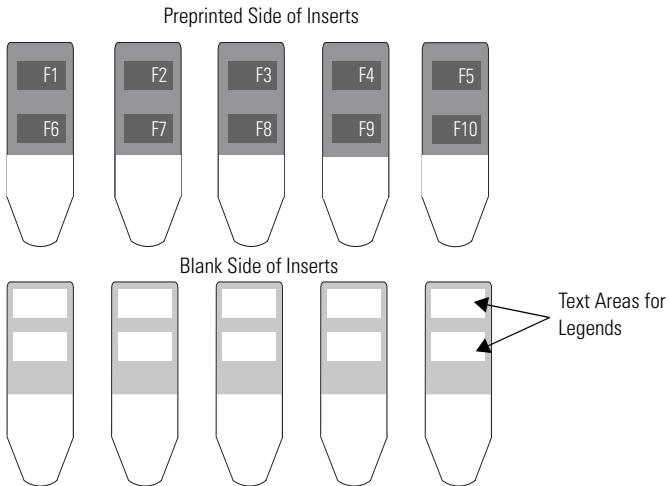

Labeling Inserts

When custom labeling the inserts, use an indelible type marker. Make sure the triangular shaped end is facing down (as shown above). All printing must appear within the white text areas. It is recommended that you test print the legends on a separate sheet of paper to verify that the insert has adequate space for the legends.

Install the Legend Key Inserts

Installing the key legend inserts is easiest when the terminal is not mounted. The instructions that follow describe how to install the inserts when the PanelView terminal is not mounted.

Follow these steps to install the key legend inserts.

1. Turn off power to PanelView 500 terminal.

ATTENTION

Disconnect power to the terminal before removing cables and installing inserts. Failure to disconnect power could result in an electrical shock.



2. Remove all installation cables to facilitate installation of the inserts.
3. With the terminal removed from the panel and upside down, locate the 5 slots for the legend inserts.

Slots for Legend
Inserts

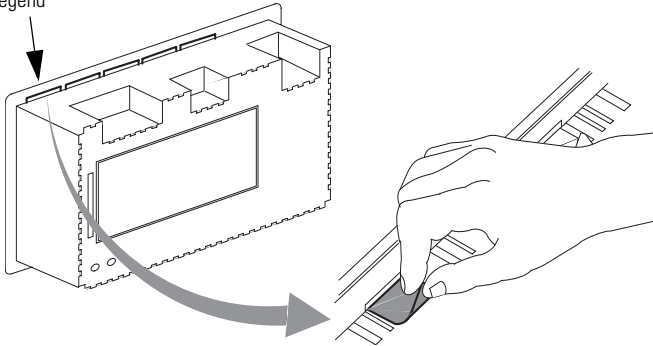

4. Grasp the tab of the old legend insert and pull to remove.
5. Slide the new insert into the slot (as far as it will go) so that the printed side will face the front of the terminal.
6. Check the front of the terminal to verify that the inserts properly identify the function keys.

PanelView 550 Terminal Function Key Legend Kit

Référence 2711-NF1

Français

Description

Le Kit de Légendes des Touches Fonctions contient 5 inserts. Une des faces des inserts est prémarquée avec les légendes des touches fonctions F1 à F10. L'autre face de chaque insert est blanche et possède deux zones de texte pour des étiquettes de touches fonctions. Utiliser la face blanche des inserts pour marquer les touches fonctions pour une application spécifique.

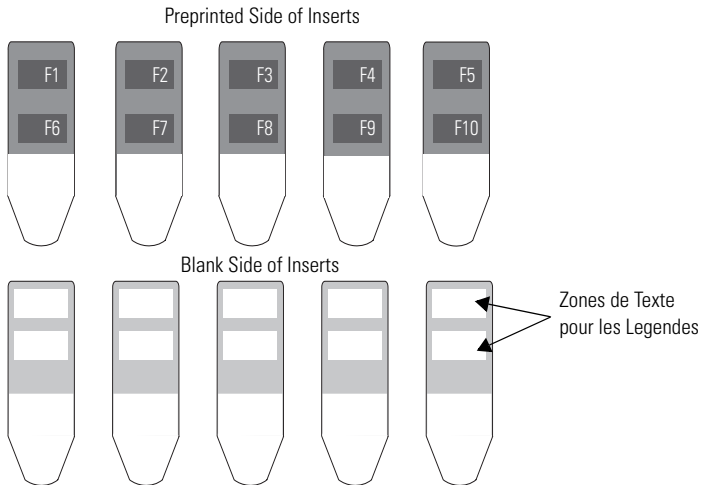

Marquage des Inserts

Si on veut personnaliser les légendes, utiliser un marqueur de type indélébile. Vérifier que l'extrémité de forme triangulaire est dirigée vers le bas (comme indiqué ci-dessus). Tout le marquage doit apparaître dans les zones blanches de texte. Il est conseillé d'essayer de marquer les légendes sur une autre feuille de papier pour vérifier qu'il y a assez de place pour les légendes sur les inserts.

Installation des Inserts de Légendes

L'installation des inserts de légendes pour les touches est plus facile quand le terminal n'est pas monté. Les instructions qui suivent décrivent comment installer les inserts quand le Terminal PanelView n'est pas monté.

Pour installer les inserts de légendes des touches:

1. Couper l'alimentation du Terminal PanelView 550.

ATTENTION

Débrancher l'alimentation du terminal avant d'enlever les câbles et d'installer les inserts. Ne pas débrancher l'alimentation pourrait exposer à des décharges électriques.



2. Retirer tous les câbles pour faciliter l'installation des inserts.
3. Enlever le terminal du panneau, le retourner et localiser les 5 fentes pour les inserts de légendes.

Fentes pour les
Inserts de Légendes

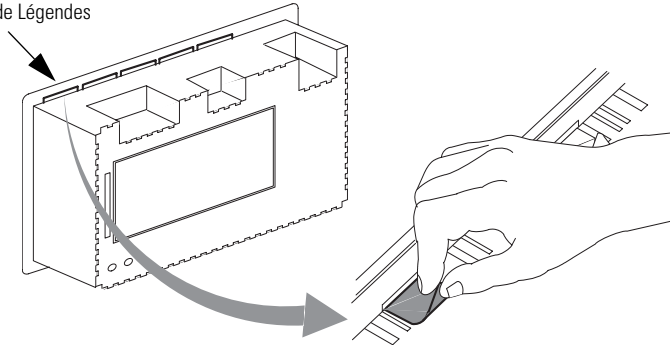

4. Saisir la languette de l'ancien insert de légende et la tirer pour l'enlever.
5. Glisser le nouvel insert dans la fente (aussi loin que possible) afin que le côté imprimé soit face à l'avant du terminal.
6. Vérifier sur la face avant du terminal que les inserts identifient convenablement les touches fonctions.

PanelView 550 Terminal Function Key Legend Kit

Katalog-Nr. 2711-NF1

Deutsch

Beschreibung

Der Funktionstasten-Beschriftungssatz enthalten 5 Einsätze. Eine Seite der Einsätze ist mit den Funktionstasten-Legenden F1 bis F10 vorbeschriftet. Die andere Seite jedes Einsatzes ist leer und hat ein Textgebiet für 2 Funktionstasten-Beschriftungen. Benutzen Sie die leere Seite der Einsätze, um die Funktionstasten für eine spezifische Anwendung zu beschriften.

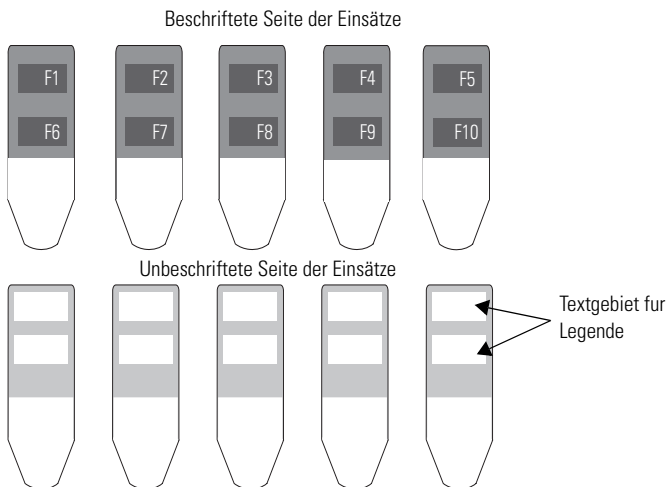

Beschriftung der Einsätze

Für die eigenspezifische Beschriftung der Einsätze benutzen Sie einen wasserfesten Stift. Vergewissern Sie sich, daß das dreieckig gestaltete Ende nach unten zeigt (wie oben gezeigt). Die Beschriftung muß innerhalb des weißen Textgebietes erfolgen. Es wird empfohlen, daß Sie die Textgröße erst auf einem separaten Blatt Papier überprüfen, um zu bestätigen, daß der angemessene Platz für die Legende zur Verfügung steht.

Installieren des Beschriftungssatzes

Das Installieren der Beschriftungseinsätze ist am leichtesten, wenn das Terminal nicht eingebaut ist. Die folgenden Anweisungen beschreiben, wie die Einsätze in das nicht eingebaute PanelView Terminal zu installieren sind.

Installation der Beschriftungen:

1. Schalten Sie Spannungsversorgung des PanelView 550 Terminals aus.

ACHTUNG



Schalten Sie Spannungsversorgung zum Terminal ab, bevor Sie Kabel entfernen und Einsätze installieren. Das Nichtabschalten der Spannungsversorgung kann einen elektrischen Schlag zur Folge haben.

2. Entfernen Sie alle angeschlossenen Kabel, um die Installation der Einsätze zu erleichtern.
3. Drehen Sie das ausgebaute Terminal um, so daß die Unterseite nach oben zeigt. Machen Sie die 5 Schlitz für die Beschriftungen ausfindig.

Schlitz für Legende

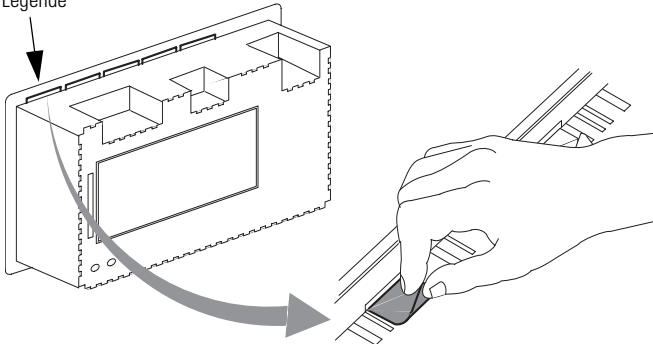

4. Greifen Sie die Lasche und ziehen Sie die alte Beschriftung heraus.
5. Schieben Sie den neuen Einsatz (so weit wie es geht) in den Schlitz, so daß die Beschriftung zur Vorderseite des Terminals zeigt.
6. Prüfen Sie die Vorderseite des Terminals, um die ordentliche Identifizierung der Funktionstasten zu bestätigen.

PanelView 550 Terminal Function Key Legend Kit

N. di catalogo 2711-NF1

Italiano

Descrizione

Il set legenda per tasti di funzione contiene 5 inserti ed un inserto prestampato su un lato con le etichette F1 - F10. L'altro lato di ciascun inserto con spazio in bianco, ha delle aree di testo per 2 etichette per tasti di funzione. Utilizzare il lato con spazio in bianco per marcare i tasti di funzione utilizzati per applicazioni specifiche.

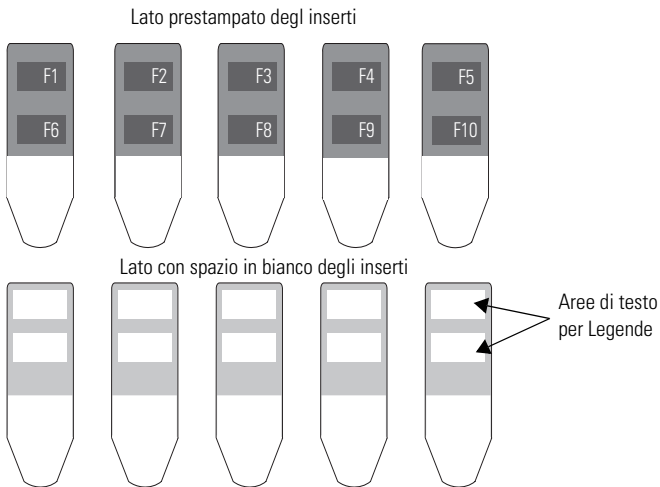

Marcatura degli inserti

Usare un pennarello indelebile per la personalizzazione delle etichette. Accertarsi che l'estremità a forma triangolare sia rivolta verso il basso (come illustrato sopra). Tutta la stampa dovrà apparire nell'area con testo bianco. Si raccomanda di fare delle prove su un foglio separato di carta per accertarsi che l'inserto abbia lo spazio necessario per le legende.

Installazione degli inserti

L'installazione degli inserti legenda è più facile se il terminale non è montato. Le seguenti istruzioni descrivono quindi come installare gli inserti quando il terminale PanelView non è montato.

Per installare gli inserti legenda:

1. Disinserire la corrente dal terminale PanelView 500.

ATTENZIONE



Disinserire la corrente dal terminale prima di rimuovere i cavi e di installare gli inserti. Procedimenti contrari a queste indicazioni possono risultare in scosse elettriche ed infortuni alla persona.

2. Rimuovere tutti i cavi di installazione per facilitare l'installazione degli inserti.
3. Con il terminale capovolto e rimosso dal pannello, trovare i 5 slot per gli inserti legenda..

Slot per Inserti
legenda

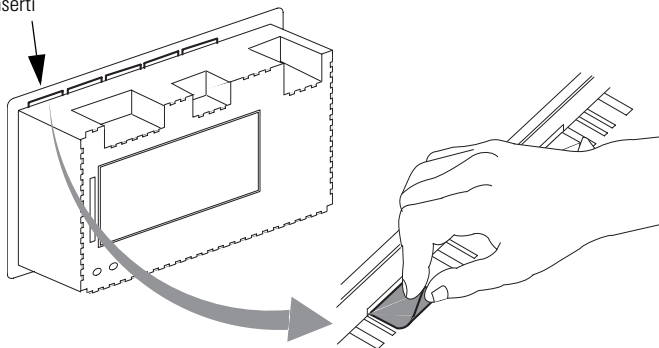

4. Tirare la linguetta e rimuovere l'inserto vecchio.
5. Fare entrare (il più possibile) il nuovo inserto nello slot in modo che il lato stampato sia visibile dalla parte frontale del terminale.
6. Controllare la parte frontale del terminale per accertarsi che i tasti di funzione siano identificati correttamente dagli inserti.

PanelView 550 Terminal Function Key Legend Kit

No. de catálogo 2711-NF1

Español

Descripción

El conjunto de leyendas para las teclas de función tiene 5 inserciones. Un lado de las inserciones ya está impresa con las leyendas de teclas de función F1 a F10. El otro lado de cada inserción está en blanco y tiene áreas de texto para 2 etiquetas de tecla de función. Use el lado en blanco para rotular las teclas de función de una aplicación específica.

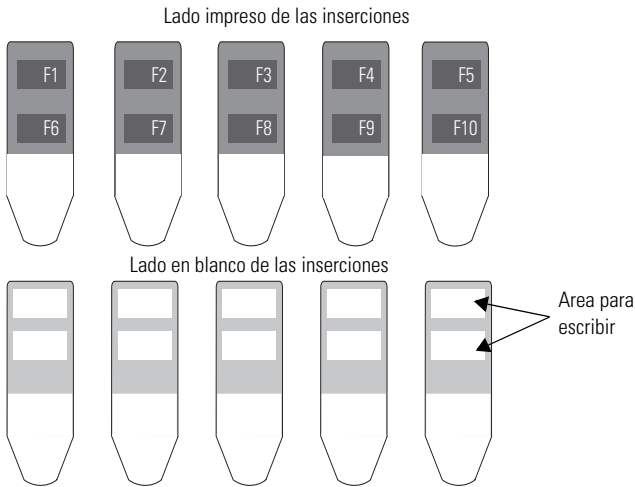

Cómo rotular las inserciones

Use un marcador de tinta permanente al rotular las inserciones con texto personalizado. Asegúrese que la parte triangular esté hacia abajo (como se muestra arriba). Toda la impresión debe aparecer dentro de las áreas blancas. Se recomienda que pruebe la impresión de leyendas en un papel distinto para que se asegure que la inserción tenga suficiente espacio para la leyenda.

Cómo instalar las inserciones de leyenda

Es mucho más fácil instalar la inserción de leyenda cuando el terminal no está montado. Las siguientes instrucciones describen como instalar las inserciones cuando el terminal PanelView no está montado.

Para instalar las inserciones de leyenda:

1. Apague el terminal PanelView 500.

ATENCIÓN

Desconecte la alimentación eléctrica al terminal antes de desconectar los cables e instalar las inserciones. El no hacer esto puede resultar en un choque eléctrico.



2. Desconecte todos los cables de instalación para facilitar la instalación de las inserciones.
3. Después de quitar el terminal, póngalo boca abajo y encuentre las 5 ranuras para inserción de leyendas.

Ranuras para las inserciones

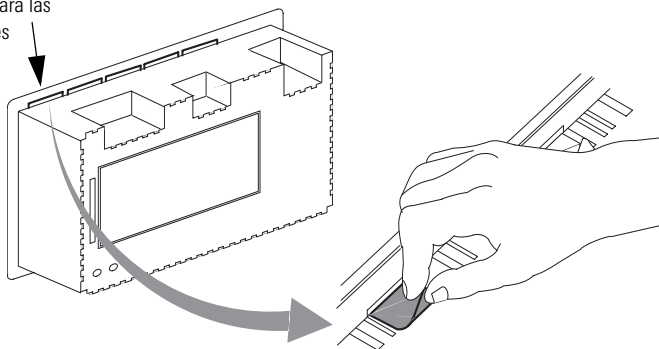

4. Agarre la pestaña de la inserción antigua y tire para quitarla.
5. Deslice la nueva inserción en la ranura (hasta adentro) para que el lado impreso se vea en la parte frontal del terminal.
6. Revise la parte frontal del terminal para asegurarse que las inserciones identifiquen correctamente las teclas de función.

Rockwell Automation Support

Rockwell Automation provides technical information on the Web to assist you in using its products. At <http://support.rockwellautomation.com>, you can find technical manuals, a knowledge base of FAQs, technical and application notes, sample code and links to software service packs, and a MySupport feature that you can customize to make the best use of these tools.

For an additional level of technical phone support for installation, configuration and troubleshooting, we offer TechConnect support programs. For more information, contact your local distributor or Rockwell Automation representative, or visit <http://support.rockwellautomation.com>.

Installation Assistance

If you experience a problem within the first 24 hours of installation, please review the information that's contained in this manual. You can also contact a special Customer Support number for initial help in getting your product up and running.

United States	1.440.646.3434 Monday – Friday, 8 a.m. – 5 p.m. EST
Outside United States	Please contact your local Rockwell Automation representative for any technical support issues.

New Product Satisfaction Return

Rockwell Automation tests all of its products to ensure that they are fully operational when shipped from the manufacturing facility. However, if your product is not functioning and needs to be returned, follow these procedures.

United States	Contact your distributor. You must provide a Customer Support case number (see phone number above to obtain one) to your distributor in order to complete the return process.
Outside United States	Please contact your local Rockwell Automation representative for the return procedure.

Allen-Bradley, Rockwell Automation, PanelView, and TechConnect are trademarks of Rockwell Automation, Inc.

Trademarks not belonging to Rockwell Automation are property of their respective companies.

www.rockwellautomation.com

Power, Control and Information Solutions Headquarters

Americas: Rockwell Automation, 1201 South Second Street, Milwaukee, WI 53204-2496 USA, Tel: (1) 414.382.2000, Fax: (1) 414.382.4444
Europe/Middle East/Africa: Rockwell Automation, Vortfaan/Boulevard du Souverain 36, 1170 Brussels, Belgium, Tel: (32) 2 663 0600, Fax: (32) 2 663 0640
Asia Pacific: Rockwell Automation, Level 14, Core F, Cyberport 3, 100 Cyberport Road, Hong Kong, Tel: (852) 2887 4788, Fax: (852) 2508 1846

Publication 2711-IN046B-MU-P - August 2007

PN -14894

Supersedes Publication 40061-183-01(A) - 1994

Copyright © 2007 Rockwell Automation, Inc. All rights reserved. Printed in the U.S.A.