



PanelView Display Backlight

Catalog Numbers

Terminal	Backlight Cat. No.
PanelView 1000 Color	2711-NL4
PanelView 900 Color	2711-NL2
PanelView 600	2711-NL3

Topic	Page
About This Publication	1
Important User Information	2
Safety Precautions	3
About the Backlight	3
Remove the Backlight	3
Install the Backlight	5
Backlight Disposal	6

About This Publication

This publication describes how to replace the backlight in the PanelView 1000 Color, PanelView 900 Color, and PanelView 600 terminals.

Important User Information

Solid state equipment has operational characteristics differing from those of electromechanical equipment. Safety Guidelines for the Application, Installation and Maintenance of Solid State Controls (publication SGI-1.1 available from your local Rockwell Automation sales office or online at <http://literature.rockwellautomation.com>) describes some important differences between solid state equipment and hard-wired electromechanical devices. Because of this difference, and also because of the wide variety of uses for solid state equipment, all persons responsible for applying this equipment must satisfy themselves that each intended application of this equipment is acceptable.





In no event will Rockwell Automation, Inc. be responsible or liable for indirect or consequential damages resulting from the use or application of this equipment.

The examples and diagrams in this manual are included solely for illustrative purposes. Because of the many variables and requirements associated with any particular installation, Rockwell Automation, Inc. cannot assume responsibility or liability for actual use based on the examples and diagrams.

No patent liability is assumed by Rockwell Automation, Inc. with respect to use of information, circuits, equipment, or software described in this manual.

Reproduction of the contents of this manual, in whole or in part, without written permission of Rockwell Automation, Inc., is prohibited.

Throughout this manual, when necessary, we use notes to make you aware of safety considerations.

<p>WARNING</p> 	<p>Identifies information about practices or circumstances that can cause an explosion in a hazardous environment, which may lead to personal injury or death, property damage, or economic loss.</p>
<p>IMPORTANT</p>	<p>Identifies information that is critical for successful application and understanding of the product.</p>
<p>ATTENTION</p> 	<p>Identifies information about practices or circumstances that can lead to personal injury or death, property damage, or economic loss. Attentions help you to identify a hazard, avoid a hazard, and recognize the consequences.</p>
<p>SHOCK HAZARD</p> 	<p>Labels may be on or inside the equipment, for example, a drive or motor, to alert people that dangerous voltage may be present.</p>
<p>BURN HAZARD</p> 	<p>Labels may be on or inside the equipment, for example, a drive or motor, to alert people that surfaces may reach dangerous temperatures.</p>

Safety Precautions

ATTENTION



Disconnect all power from the PanelView terminal before replacing the backlight. Failure to disconnect power may result in electrical shock and/or damage to the terminal.

ATTENTION



Do not touch any of the exposed electronic components to prevent damage from electrostatic discharge (ESD).

About the Backlight

The backlight uses cold cathode fluorescent (CCF) tubes to illuminate the display. The procedures for replacing the backlight apply to the different terminal types.

Remove the Backlight

Follow these steps to remove the backlight from the terminal.

1. Turn off the power to the PanelView terminal.
2. Loosen the Phillips-head captive fasteners.

The PanelView 900/1000 terminals have four fasteners as shown; the PanelView 600 terminal has two fasteners.

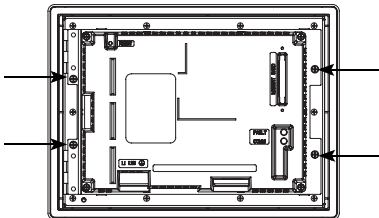

PanelView 900/1000
(4) Phillips Captive Fasteners

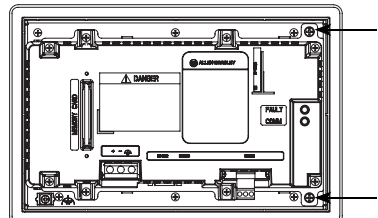

PanelView 600 (2) Phillips Captive Fasteners

4 PanelView Display Backlight

3. Open the back of the PanelView terminal by swinging the unit open about 90°.

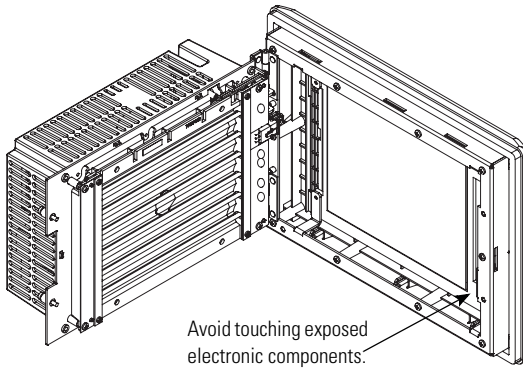

4. Unplug the backlight power supply cable and remove it from the molded cable retainers (not present on PV600 terminal) on the backlight reflector and set aside.

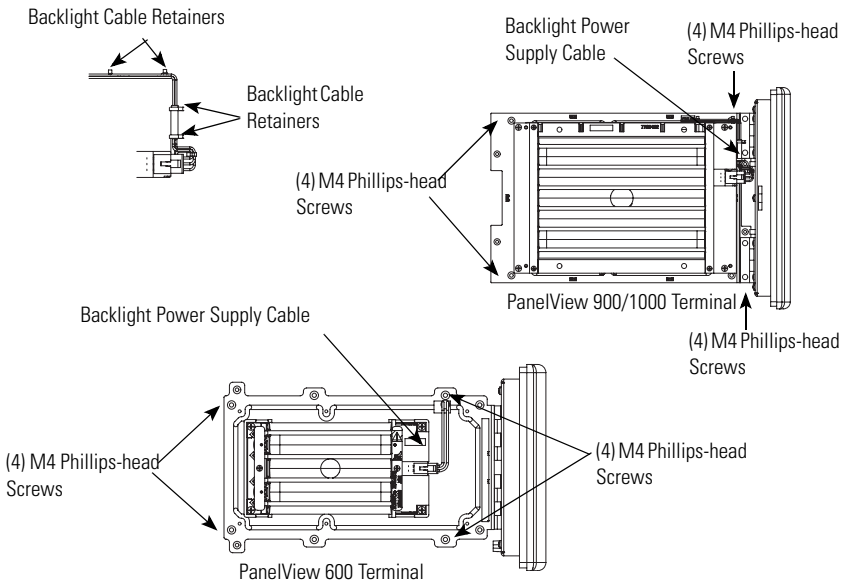

5. Remove the four Phillips-head screws and remove the backlight.

Install the Backlight

Follow these steps to install the backlight in the terminal.

1. Place the new backlight on the four backlight standoffs.
2. Replace the four backlight mounting screws and tighten to a torque of 0.7...0.9 Nm (6...8 lb-in).
3. Place the backlight power supply cable under the cable retainers on the backlight reflector (PV900C/PV1000C terminals only) and plug into the new backlight.
4. Swing the chassis back into position and tighten the two (PanelView 600 terminal) or four (PV900C/PV1000C terminals) captive screws to a torque of 0.7...0.9 Nm (6...8 lb-in).
5. Apply power and verify operation of the backlight.
6. If the display does not illuminate, refer to the troubleshooting chart in the PanelView Standard User Manual, publication 2711-UM014.

Backlight Disposal

IMPORTANT

The backlight in this product contains mercury. At the end of its life, this equipment should be collected separately from any unsorted municipal waste.

Notes:

Rockwell Automation Support

Rockwell Automation provides technical information on the Web to assist you in using its products. At <http://support.rockwellautomation.com>, you can find technical manuals, a knowledge base of FAQs, technical and application notes, sample code and links to software service packs, and a MySupport feature that you can customize to make the best use of these tools.

For an additional level of technical phone support for installation, configuration, and troubleshooting, we offer TechConnect Support programs. For more information, contact your local distributor or Rockwell Automation representative, or visit <http://support.rockwellautomation.com>.

Installation Assistance

If you experience a problem with a hardware module within the first 24 hours of installation, please review the information that's contained in this manual. You can also contact a special Customer Support number for initial help in getting your module up and running.

United States	1.440.646.3434 Monday – Friday, 8am – 5pm EST
Outside United States	Please contact your local Rockwell Automation representative for any technical support issues.

New Product Satisfaction Return

Rockwell tests all of its products to ensure that they are fully operational when shipped from the manufacturing facility. However, if your product is not functioning, it may need to be returned.

United States	Contact your distributor. You must provide a Customer Support case number (see phone number above to obtain one) to your distributor in order to complete the return process.
Outside United States	Please contact your local Rockwell Automation representative for return procedure.

Rockwell Automation, Allen-Bradley, TechConnect, and PanelView are trademarks of Rockwell Automation, Inc.

Trademarks not belonging to Rockwell Automation are property of their respective companies.

www.rockwellautomation.com

Power, Control and Information Solutions Headquarters

Americas: Rockwell Automation, 1201 South Second Street, Milwaukee, WI 53204-2496 USA, Tel: (1) 414.382.2000, Fax: (1) 414.382.4444

Europe/Middle East/Africa: Rockwell Automation, Vorstlaan/Boulevard du Souverain 36, 1170 Brussels, Belgium, Tel: (32) 2 663 0600, Fax: (32) 2 663 0640

Asia Pacific: Rockwell Automation, Level 14, Core F, Cyberport 3, 100 Cyberport Road, Hong Kong, Tel: (852) 2887 4788, Fax: (852) 2508 1846

Publication 2711-IN042C-EN-P - July 2007

PN -14546

Supersedes Publication 2711-IN042B-EN-P - April 2007

Copyright © 2007 Rockwell Automation, Inc. All rights reserved. Printed in the U.S.A.