



## **Display Backlight for PanelView 600 (Series C)**

(Cat. No. 2711-NL5 - Series C)

### **Inside. . .**

English Section .....	3
Section en français .....	7
Deutscher Abschnitt .....	11
Sezione in Italiano .....	15
Sección en español .....	19
Seção em português .....	23

**Important User Information**

Solid state equipment has operational characteristics differing from those of electromechanical equipment. *Safety Guidelines for the Application, Installation and Maintenance of Solid State Controls* (Publication SGI-1.1 available from your local Rockwell Automation sales office or online at <http://www.ab.com/manuals/gi>) describes some important differences between solid state equipment and hard-wired electromechanical devices. Because of this difference, and also because of the wide variety of uses for solid state equipment, all persons responsible for applying this equipment must satisfy themselves that each intended application of this equipment is acceptable.





In no event will Rockwell Automation, Inc. be responsible or liable for indirect or consequential damages resulting from the use or application of this equipment.

The examples and diagrams in this manual are included solely for illustrative purposes. Because of the many variables and requirements associated with any particular installation, Rockwell Automation, Inc. cannot assume responsibility or liability for actual use based on the examples and diagrams.

No patent liability is assumed by Rockwell Automation, Inc. with respect to use of information, circuits, equipment, or software described in this manual.

Reproduction of the contents of this manual, in whole or in part, without written permission of Rockwell Automation, Inc. is prohibited.

Throughout this manual we use notes to make you aware of safety considerations.

<p><b>WARNING</b></p> 	<p>Identifies information about practices or circumstances that can cause an explosion in a hazardous environment, which may lead to personal injury or death, property damage, or economic loss.</p>
<p><b>IMPORTANT</b></p>	<p>Identifies information that is critical for successful application and understanding of the product.</p>
<p><b>ATTENTION</b></p> 	<p>Identifies information about practices or circumstances that can lead to personal injury or death, property damage, or economic loss. Attentions help you:</p> <ul style="list-style-type: none"><li>• identify a hazard</li><li>• avoid a hazard</li><li>• recognize the consequence</li></ul>
<p><b>SHOCK HAZARD</b></p> 	<p>Labels may be located on or inside the drive to alert people that dangerous voltage may be present.</p>
<p><b>BURN HAZARD</b></p> 	<p>Labels may be located on or inside the drive to alert people that surfaces may be dangerous temperatures.</p>



# Display Backlight for PanelView 600 (Series C)

## English Section

This instruction sheet describes how to replace the backlight in the following PanelView terminal:

Terminal	Backlight Catalog Number
PanelView 600 (Series C)	2711-NL5

### TIP

This publication excludes PanelView 600 Touch only.

## Kit Contents

- Replacement backlight (quantity 2)
- Bezel screws (quantity 6)
- Display mounting plate screws (quantity 4)

The backlight uses Cold Cathode Fluorescent Lamp (CCFL) tubes to illuminate the display.

### ATTENTION



- Disconnect all power from the PanelView terminal before replacing the backlight. Failure to disconnect power may result in electrical shock and/or damage to the terminal.
- Do not touch any of the exposed electronic components to prevent damage from electrostatic discharge (ESD).
- Installer must use proper Anti-ESD equipment.

## To Remove the Backlight

1. Turn off the power to the PanelView terminal.
2. Lay terminal on front. Remove six bezel screws from the shroud.

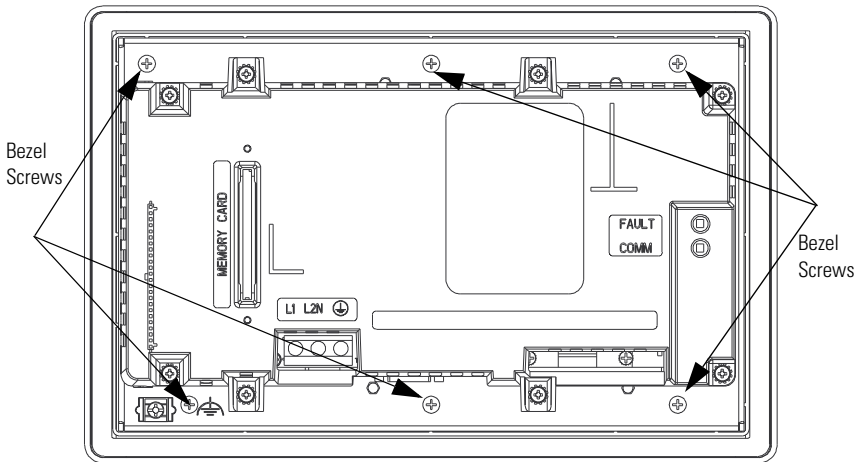

3. Turn terminal over and rest on back cover.
4. Open bezel to the right. Use caution with cables; prop up bezel so cables are not strained.

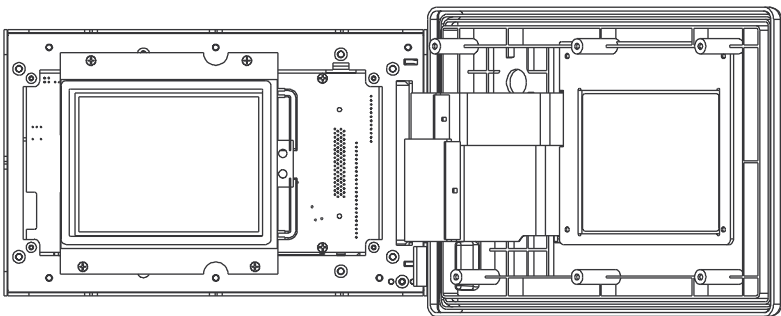

5. Disconnect cables to backlights.
6. Unscrew 4 display mounting plate screws.
7. Turn display to side, remove backlights by pressing tab and gently pulling straight out on wires.

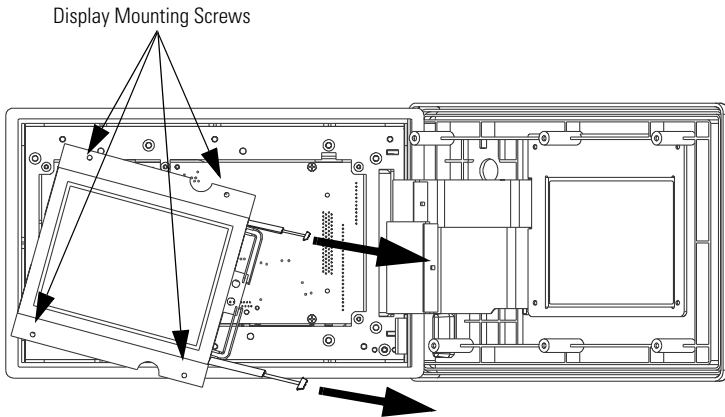

8. Properly dispose of old tubes.

## To Install the Backlight

1. Install new backlights. Ensure backlights click into place.
2. Place display mounting plate over standoffs and install four display mounting plate screws. (Replacement screws are provided.) Torque to 6 to 8 in-lb (0.68 to 0.90 Nm).
3. Plug backlights into appropriate cable, making sure cables click together firmly.
4. Ensure back of display window is clean and slide bezel into place making sure to be careful with the bezel connection.
5. Install six bezel screws. (Replacement screws are provided.) Torque to 12 to 14 in-lb (1.35 to 1.58 Nm).
6. Apply power and verify operation of the backlight.
7. If the display does not illuminate, refer to the troubleshooting chart in the PanelView Standard User Manual, publication 2711-UM014. Recheck all connections and free pathways for cabling.



## Rétroéclairage pour PanelView 600 (série C)

### Section en français

Cette notice explique comment remplacer le rétroéclairage des terminaux PanelView suivants :

Terminal	Référence du rétroéclairage
PanelView 600 (série C)	2711-NL5

#### CONSEIL

Cette publication ne porte pas sur les PanelView 600 à dalle tactile seule.

### Contenu du kit

- Rétroéclairage de rechange (quantité 2)
- Vis pour la face avant (quantité 6)
- Vis pour la plaque de fixation de l'écran (quantité 4)

L'écran est éclairé grâce à des lampes fluorescentes à cathode froide (CCFL).

#### ATTENTION



- Coupez toute alimentation du terminal PanelView avant de remplacer le rétroéclairage. En cas de non-respect de cette consigne, vous risquez de vous électrocuter et/ou d'endommager le terminal.
- Ne touchez pas les composants électroniques exposés pour éviter de les endommager par une décharge électrostatique.
- L'installateur doit utiliser un équipement antistatique approprié.

## Dépose du rétroéclairage

1. Coupez l'alimentation du terminal PanelView.
2. Posez le terminal sur sa face avant. Retirez les six vis qui maintiennent le boîtier fermé.

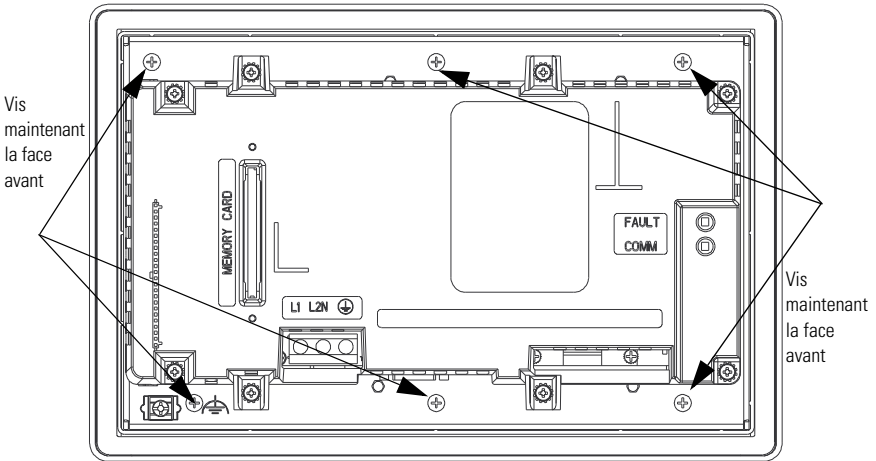

3. Retournez le terminal et posez-le sur sa face arrière.
4. Ouvrez la face avant vers la droite. Manipulez les câbles avec précaution ; soutenez la face avant afin de ne pas exercer de tension sur les câbles.

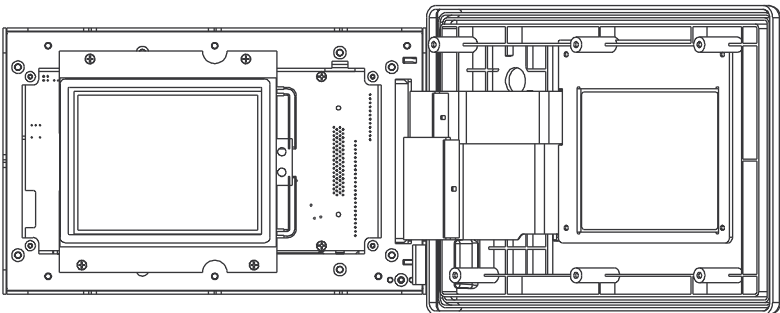



5. Débranchez les câbles du rétroéclairage.
6. Retirez les 4 vis de la plaque de fixation de l'écran.
7. Tournez l'écran sur le côté, retirez les lampes en appuyant sur la languette et en tirant doucement sur les fils.

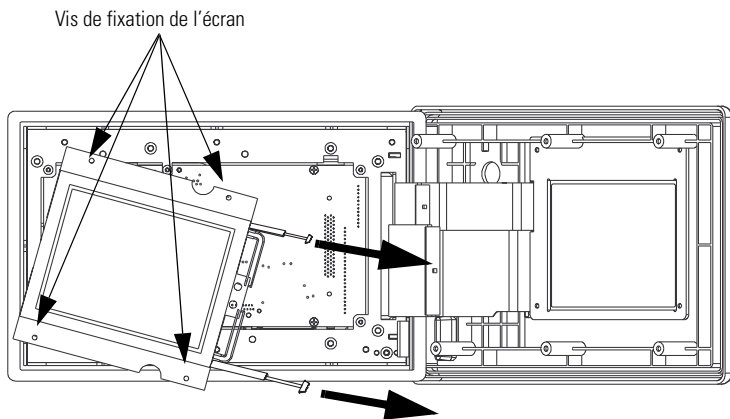

8. Mettez les lampes usagées au rebut en vous conformant à la réglementation en vigueur.

## Mise en place du rétroéclairage

1. Installez le nouveau rétroéclairage. Veillez à ce que les lampes s'enclenchent bien.
2. Placez la plaque de fixation de l'écran sur les espaceurs et remettez en place les quatre vis de la plaque de fixation de l'écran (des vis de rechange sont fournies). Serrez les vis avec un couple de 0,68 - 0,90 Nm.
3. Branchez les lampes sur les câbles appropriés, en veillant à ce que ces derniers s'insèrent bien.
4. Vérifiez que la face antérieure de la fenêtre de l'écran est propre et refermez la face avant en veillant à sa connexion.
5. Remettez les six vis de la face avant en place (des vis de rechange sont fournies). Serrez les vis avec un couple de 1,35 - 1,58 Nm.
6. Mettez le terminal sous tension et vérifiez le fonctionnement du rétroéclairage.
7. Si l'écran ne s'allume pas, consultez le tableau de dépannage dans le manuel utilisateur des PanelView standard (publication 2711-UM014). Vérifiez de nouveau toutes les connexions et assurez-vous que rien ne gêne l'acheminement des câbles.

## Anzeigenhintergrundbeleuchtung für PanelView 600 (Serie C)

### Deutscher Abschnitt

In dieser Anleitung wird beschrieben, wie die Hintergrundbeleuchtung des folgenden PanelView-Terminals ausgewechselt wird:

Terminal	Best.-Nr. der Hintergrundbeleuchtung
PanelView 600 (Serie C)	2711-NL5

#### TIPP

Nur das Terminal PanelView 600 mit Touchscreen wird von dieser Publikation ausgeschlossen.

### Inhalt des Kits

- Ersatzhintergrundbeleuchtung (2 Stück)
- Schrauben für Frontplatte (6 Stück)
- Schrauben für die Montageplatte der Anzeige (4 Stück)

Die Hintergrundbeleuchtung verwendet zur Beleuchtung der Anzeige Kaltkathoden-Fluoreszenzröhren.

#### ACHTUNG



- Unterbrechen Sie vor dem Ersetzen der Hintergrundbeleuchtung die Stromversorgung zum PanelView-Terminal. Wird die Stromversorgung nicht unterbrochen, kann dies zu Stromschlägen und/oder zur Beschädigung des Terminals führen.
- Berühren Sie auf keinen Fall die freigelegten elektronischen Komponenten, um Schäden durch elektrostatische Entladung zu vermeiden.
- Verwenden Sie bei der Installation eine geeignete Antistatik-Vorrichtung.

## So entfernen Sie die Hintergrundbeleuchtung:

1. Schalten Sie das PanelView-Terminal aus.
2. Legen Sie das Terminal auf die Vorderseite. Drehen Sie die sechs Schrauben aus der Frontplatte heraus.

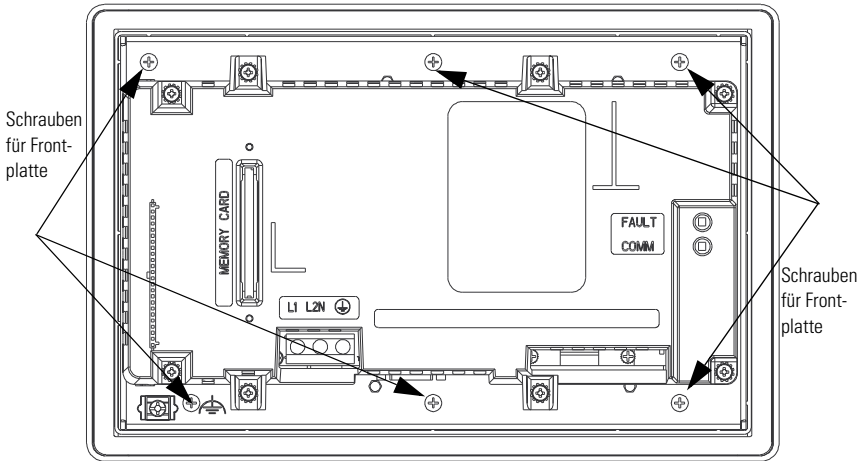

3. Drehen Sie das Terminal um, und legen Sie es auf die hintere Abdeckung.
4. Öffnen Sie die Frontplatte, indem Sie sie nach rechts klappen. Die Kabel müssen vorsichtig gehandhabt werden; stützen Sie die Platte ab, damit die Kabel nicht überspannt werden.

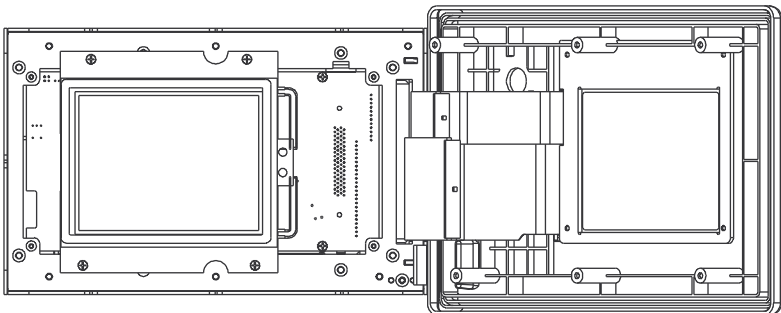

5. Trennen Sie die Kabel von den Hintergrundleuchten.
6. Lösen Sie die vier Schrauben der Anzeigenmontageplatte.
7. Legen Sie die Anzeige auf die Seite. Entfernen Sie die Hintergrundleuchten, indem Sie auf die Verriegelungslasche drücken und gleichzeitig die Drähte vorsichtig und gerade herausziehen.

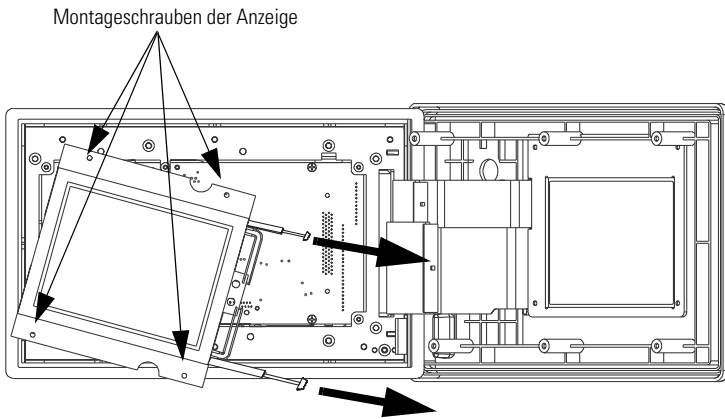

8. Entsorgen Sie die alten Röhren ordnungsgemäß.

## So installieren Sie die Hintergrundbeleuchtung:

1. Installieren Sie die neuen Hintergrundleuchten. Sorgen Sie dafür, dass die Hintergrundleuchten hörbar einrasten.
2. Stellen Sie die Montageplatte der Anzeige auf die Vorsprünge, und installieren Sie die vier Schrauben der Montageplatte. (Ersatzschrauben werden mitgeliefert.) Anzugsdrehmoment für die Schrauben: 0,68 - 0,90 Nm.
3. Verbinden Sie die Hintergrundleuchten mit der entsprechenden Verkabelung. Sorgen Sie dafür, dass die Kabel sicher einrasten.
4. Achten Sie darauf, dass die Rückseite des Anzeigenfensters sauber ist, und schieben Sie die Frontplatte wieder in die richtige Position. Geben Sie dabei auf die Verbindung der Frontplatte Acht.
5. Bringen Sie die sechs Schrauben der Frontplatte wieder an. (Ersatzschrauben werden mitgeliefert.) Anzugsdrehmoment für die Schrauben: 1,35 - 1,58 Nm.
6. Schalten Sie das Gerät ein, und überprüfen Sie, ob die Hintergrundbeleuchtung ordnungsgemäß funktioniert.
7. Wenn die Anzeige nicht beleuchtet wird, ziehen Sie die Tabelle zur Fehlersuche im PanelView Standard-Benutzerhandbuch zu Rate (Publikation 2711-UM014). Überprüfen Sie erneut alle Anschlüsse und die gesamte Verkabelung.



## Retroilluminazione display per PanelView 600 (Serie C)

### Sezione in Italiano

Queste istruzioni descrivono come sostituire la retroilluminazione dei seguenti terminali PanelView:

Terminale	Num. cat. retroilluminazione
PanelView 600 (Serie C)	2711-NL5

#### CONSIGLIO

Questa pubblicazione esclude solo i PanelView 600 Touch-Screen.

### Contenuto del kit

- Lampade di retroilluminazione di ricambio (quantità 2)
- Viti della cornice (quantità 6)
- Viti per piastra di montaggio display (quantità 4)

Il sistema di retroilluminazione utilizza tubi CCFL (a lampada fluorescente con catodo freddo) per illuminare il display.

#### ATTENZIONE



- Scollegare l'alimentazione dal terminale prima di sostituire il sistema di retroilluminazione. In caso contrario, esiste il pericolo di scosse elettriche e/o danni al terminale.
- Non toccare i componenti elettronici scoperti onde evitare danni da scariche elettrostatiche (ESD).
- L'installatore deve utilizzare un'apparecchiatura anti ESD adeguata.

## Per rimuovere la retroilluminazione

1. Togliere l'alimentazione al terminale PanelView.
2. Poggiare il terminale sulla parte frontale. Rimuovere dal pannello le sei viti della cornice.

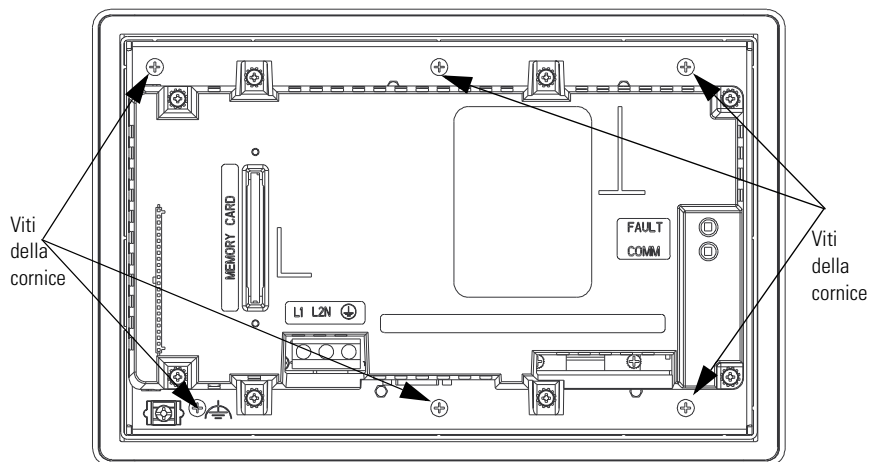

3. Girare il terminale e adagiarlo sul coperchio posteriore.
4. Aprire la cornice verso destra. Fare attenzione ai cavi; sorreggere la cornice in modo che i cavi non vengano strappati.



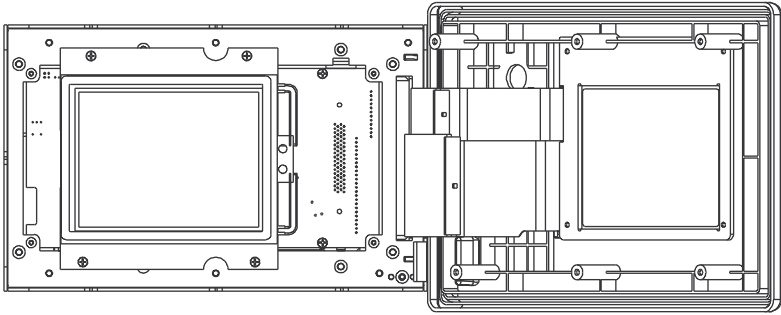

5. Scollegare i cavi della retroilluminazione.
6. Svitare le 4 viti della piastra di montaggio del display.
7. Girare il display su di un lato, rimuovere le lampade di retroilluminazione premendo la linguetta e tirando delicatamente i cavi.

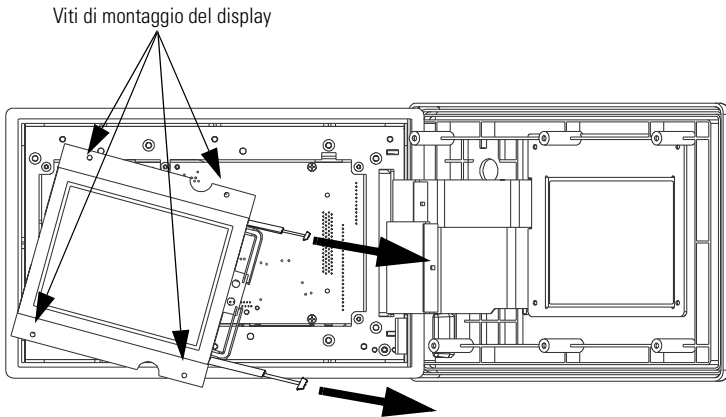

8. Disfarsi dei vecchi tubi secondo la normativa vigente.

## Per installare la retroilluminazione

1. Installare le nuove lampade di retroilluminazione. Assicurarsi che si inseriscano correttamente in posizione.
2. Inserire la piastra di montaggio del display sui distanziatori ed installare le quattro viti. (Le viti di ricambio sono fornite). Stringere le viti con una coppia di 0.68 - 0.90Nm.
3. Collegare le lampade di retroilluminazione ai cavi appropriati, assicurandosi che il collegamento sia saldo (si deve sentire un clic).
4. Accertarsi che la finestra del display sia pulita ed inserire la cornice facendo attenzione ai collegamenti.
5. Installare le 6 viti della cornice. (Le viti di ricambio sono fornite). Stringere le viti con una coppia di 1.35 - 1.58Nm.
6. Applicare l'alimentazione e verificare il funzionamento della retroilluminazione.
7. Se il display non si illumina, consultare la tabella per la ricerca guasti contenuta in PanelView Standard - Manuale dell'utente, pubblicazione 2711-UM014. Controllare tutte le connessioni e l'istadamento dei cavi.



# Retroiluminación de pantalla para PanelView 600 (serie C)

## Sección en español

Este folleto de instrucciones describe el proceso necesario para reemplazar la luz de retroiluminación en el terminal PanelView siguiente:

Terminal	Número de catálogo de la luz de retroiluminación
PanelView 600 (serie C)	2711-NL5

### CONSEJO

Esta publicación sólo excluye el modelo PanelView 600 de pantalla táctil.

## Contenido del juego

- Luz de retroiluminación de repuesto (2)
- Tornillos de bisel (6)
- Tornillos de placa de montaje de pantalla (4)

Para iluminar la pantalla, la luz de retroiluminación emplea tubos de lámpara fluorescente de cátodo frío (CCFL).

### ATENCIÓN



- Desconecte completamente la alimentación del terminal PanelView antes de reemplazar la luz de retroiluminación. Si no desconecta la alimentación eléctrica, pueden producirse descargas eléctricas y/o daños en el terminal.
- No toque los componentes electrónicos que queden al descubierto para evitar daños por descargas electrostáticas (ESD).
- El instalador deberá utilizar un equipo antiestático adecuado.

## Para retirar la luz de retroiluminación

1. Desconecte la alimentación eléctrica del terminal PanelView.
2. Coloque el terminal descansando sobre su parte frontal. Retire los seis tornillos del bisel de la cubierta.

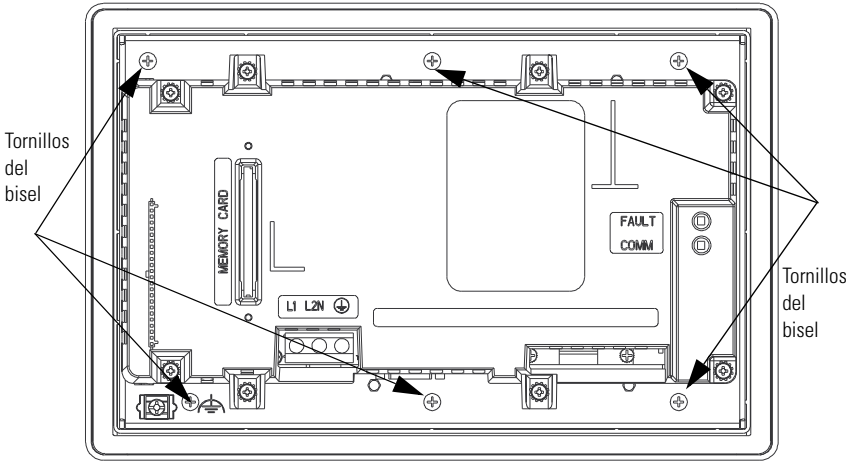

3. Dé la vuelta al terminal de manera que descance sobre la cubierta trasera.
4. Abra el bisel hacia la derecha. Tenga cuidado con los cables; sostenga el bisel para que no se tensen los cables.

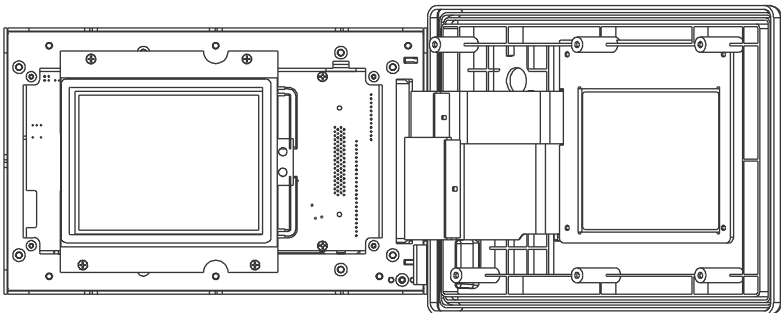

5. Desconecte los cables que van a las luces de retroiluminación.
6. Retire los 4 tornillos de la placa de montaje de la pantalla.
7. Voltee la pantalla sobre uno de sus lados, retire las luces de retroalimentación presionando la pestaña y tirando suavemente de los cables.

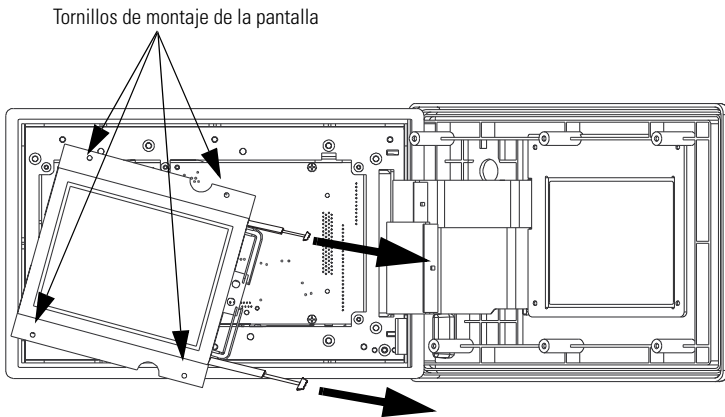

8. Deseche adecuadamente los tubos viejos.

## Para instalar la luz de retroiluminación

1. Instale las nuevas luces de retroiluminación. Asegúrese de que encajan con un clic en su lugar.
2. Sitúe la placa de montaje de la pantalla sobre los separadores e instale los cuatro tornillos de la placa de montaje de la pantalla. (Se proporcionan tornillos de repuesto.) Apriete los tornillos con un par de apriete de 0.68 - 0.90 Nm.
3. Conecte las luces con el cable adecuado, asegurándose de que los cables encajan correctamente con un clic.
4. Compruebe que la parte posterior de la pantalla esté limpia y deslice el bisel en su lugar, prestando especial atención a la conexión del bisel.
5. Instale los seis tornillos del bisel. (Se proporcionan tornillos de repuesto.) Apriete los tornillos con un par de apriete de 1.35 - 1.58 Nm.
6. Conecte la alimentación para comprobar el funcionamiento de la luz de retroiluminación.
7. Si la pantalla no se ilumina, consulte el cuadro de resolución de problemas del Manual del usuario de PanelView estándar, publicación 2711-UM014. Vuelva a comprobar todas las conexiones y las rutas por donde pasa el cableado.



# Lâmpada traseira do PanelView 600 (Série C)

## Seção em português

Esta folha de instruções descreve como substituir a lâmpada traseira no terminal PanelView a seguir:

Terminal	Código de catálogo da lâmpada traseira
PanelView 600 (Série C)	2711-NL5

### DICA

Esta publicação exclui apenas o PanelView 600 Touch.

## Conteúdo do kit

- Substituição da lâmpada traseira (2)
- Parafusos de moldura (6)
- Parafusos da placa de montagem da tela (4)

A lâmpada traseira usa tubos CCFL (luz fria fluorescente catódica) para iluminar a tela.

### ATENÇÃO



- Desconecte totalmente a alimentação do terminal PanelView antes de substituir a lâmpada traseira. Não desconectar totalmente a alimentação pode resultar em choque elétrico e/ou danos ao terminal.
- Não toque em qualquer dos componentes eletrônicos expostos para que não ocorram danos decorrentes de ESD (descarga eletrostática).
- O instalador deve usar um equipamento anti-ESD apropriado.

## Para remover a lâmpada traseira

1. Desligue a alimentação ao terminal PanelView.
2. Assente o terminal de frente. Remova os seis parafusos de moldura da proteção.

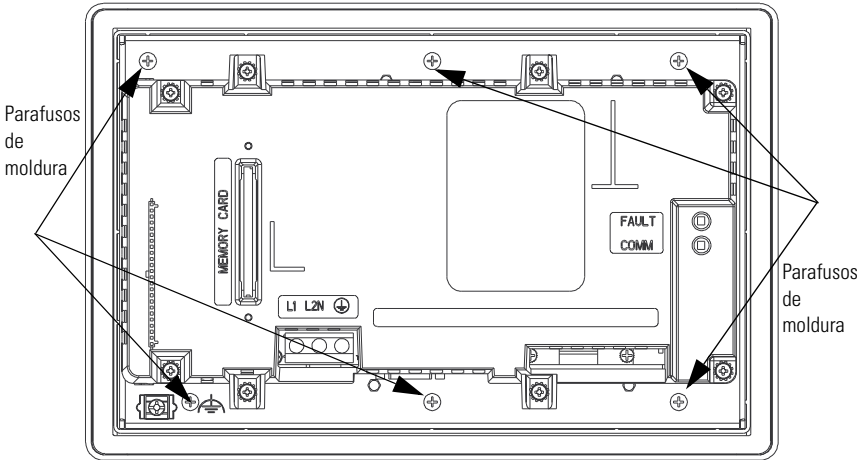

3. Vire o terminal para cima e apoie-o na tampa traseira.
4. Abra a moldura para a direita. Tenha cuidado com os cabos; escore a moldura de modo que os cabos não fiquem esticados.

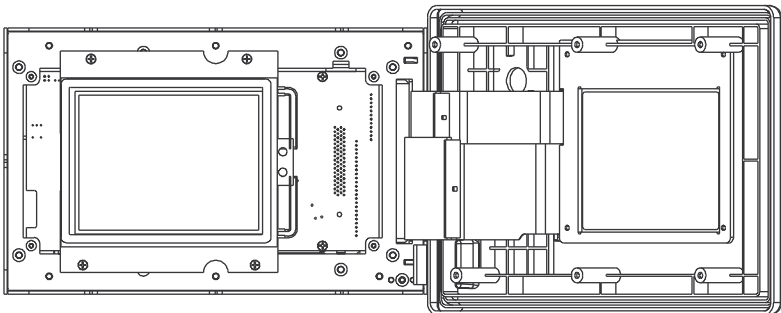



5. Desconecte os cabos das lâmpadas traseiras.
6. Solte os 4 parafusos da placa de montagem da tela.
7. Vire a tela para o lado, remova as lâmpadas traseiras pressionando a aba e, mantendo os fios retos, puxe-os cuidadosamente para fora.

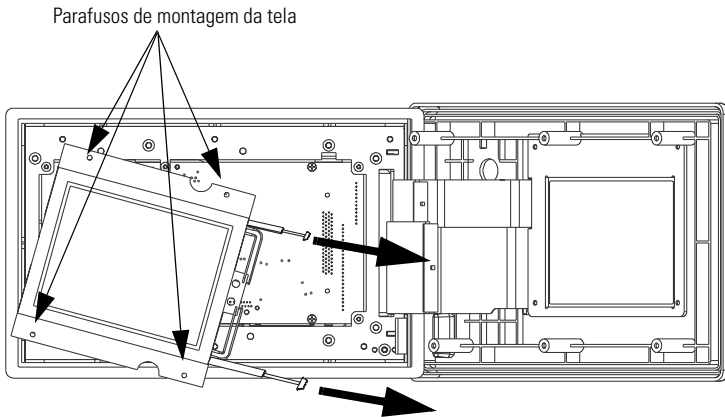

8. Descarte os tubos antigos adequadamente.

## Para instalar a lâmpada traseira

1. Instale as lâmpadas novas. Assegure-se de que elas se encaixem na posição.
2. Coloque a placa de montagem da tela sobre cavaletes e instale nela os quatro parafusos. (São fornecidos parafusos de substituição.) O torque de aperto dos parafusos é de 0,68 - 0,90 Nm.
3. Conecte as lâmpadas traseiras no cabo apropriado, certificando-se de que os cabos encaixam-se firmemente.
4. Assegure-se de que a parte de trás da janela da tela esteja limpa e deslize a moldura para dentro da posição, tomando muito cuidado com a conexão da moldura.
5. Instale seis parafusos de moldura. (São fornecidos parafusos de substituição.) O torque de aperto dos parafusos é de 1,35 - 1,58 Nm.
6. Aplique a alimentação e verifique a operação da lâmpada traseira.
7. Se o display não acender, consulte o quadro de localização de falhas no Manual do Usuário do PanelView Standard, publicação 2711-UM014. Verifique novamente todas as conexões e libere os percursos de distribuição do cabeamento.



# Rockwell Automation Support

Rockwell Automation provides technical information on the web to assist you in using our products. At <http://support.rockwellautomation.com>, you can find technical manuals, a knowledge base of FAQs, technical and application notes, sample code and links to software service packs, and a MySupport feature that you can customize to make the best use of these tools.

For an additional level of technical phone support for installation, configuration and troubleshooting, we offer TechConnect Support programs. For more information, contact your local distributor or Rockwell Automation representative, or visit <http://support.rockwellautomation.com>.

## Installation Assistance

If you experience a problem with a hardware module within the first 24 hours of installation, please review the information that's contained in this manual. You can also contact a special Customer Support number for initial help in getting your module up and running:

United States	1.440.646.3223 Monday – Friday, 8am – 5pm EST
Outside United States	Please contact your local Rockwell Automation representative for any technical support issues.

## New Product Satisfaction Return

Rockwell tests all of our products to ensure that they are fully operational when shipped from the manufacturing facility. However, if your product is not functioning and needs to be returned:

United States	Contact your distributor. You must provide a Customer Support case number (see phone number above to obtain one) to your distributor in order to complete the return process.
Outside United States	Please contact your local Rockwell Automation representative for return procedure.

[www.rockwellautomation.com](http://www.rockwellautomation.com)

### Corporate Headquarters

Rockwell Automation, 777 East Wisconsin Avenue, Suite 1400, Milwaukee, WI, 53202-5302 USA, Tel: (1) 414.212.5200, Fax: (1) 414.212.5201

### Headquarters for Allen-Bradley Products, Rockwell Software Products and Global Manufacturing Solutions

Americas: Rockwell Automation, 1201 South Second Street, Milwaukee, WI 53204-2496 USA, Tel: (1) 414.382.2000, Fax: (1) 414.382.4444

Europe: Rockwell Automation SA/NV, Vorstlaan/Boulevard du Souverain 36-BP 3A/B, 1170 Brussels, Belgium, Tel: (32) 2 663 0600, Fax: (32) 2 663 0640

Asia Pacific: Rockwell Automation, 27/F Citicorp Centre, 18 Whitfield Road, Causeway Bay, Hong Kong, Tel: (852) 2887 4788, Fax: (852) 2508 1846

### Headquarters for Dodge and Reliance Electric Products

Americas: Rockwell Automation, 6040 Ponders Court, Greenville, SC 29615-4617 USA, Tel: (1) 864.297.4900, Fax: (1) 864.281.2433

Europe: Rockwell Automation, Brühlstraße 22, D-74834 Elztal-Dallau, Germany, Tel: (49) 6261 9410, Fax: (49) 6261 17741

Asia Pacific: Rockwell Automation, 55 Newton Road, #11-01/02 Revenue House, Singapore 307987, Tel: (65) 351 6723, Fax: (65) 355 1733

Publication 2711-IN040A-MU-P - October 2003

PN 41061-339-01(1)

Copyright © 2003 Rockwell Automation, Inc. All rights reserved. Printed in the U.S.A.