



Adapter Kit for PanelView 1400e Touch Screen Terminal Cutout

2711-NR7T, 2711P-RAT12E

Description

Use the Cutout Adapter Kit to mount the following terminals into an existing PanelView 1400e Touch Screen terminal cutout.

- PanelView 1000 Touch
- PanelView 1000e Touch
- RAC6182 12.1 inch Industrial Computer Touch
- PanelView Plus 1250 Touch

Package Contents

The Cutout Adapter Kit includes:

- 1 touch screen cutout adapter plate with gasket
- 12 #10-32 nuts with flat washers

To install the terminal, you need:

- slot or Phillips screwdriver

Dimensions

The cutout adapter plate is designed to fit into the existing cutout and stud-mounts for the PanelView 1400e. The following illustration shows the cutout assembly dimensions. The dimensions are given in inches (mm).

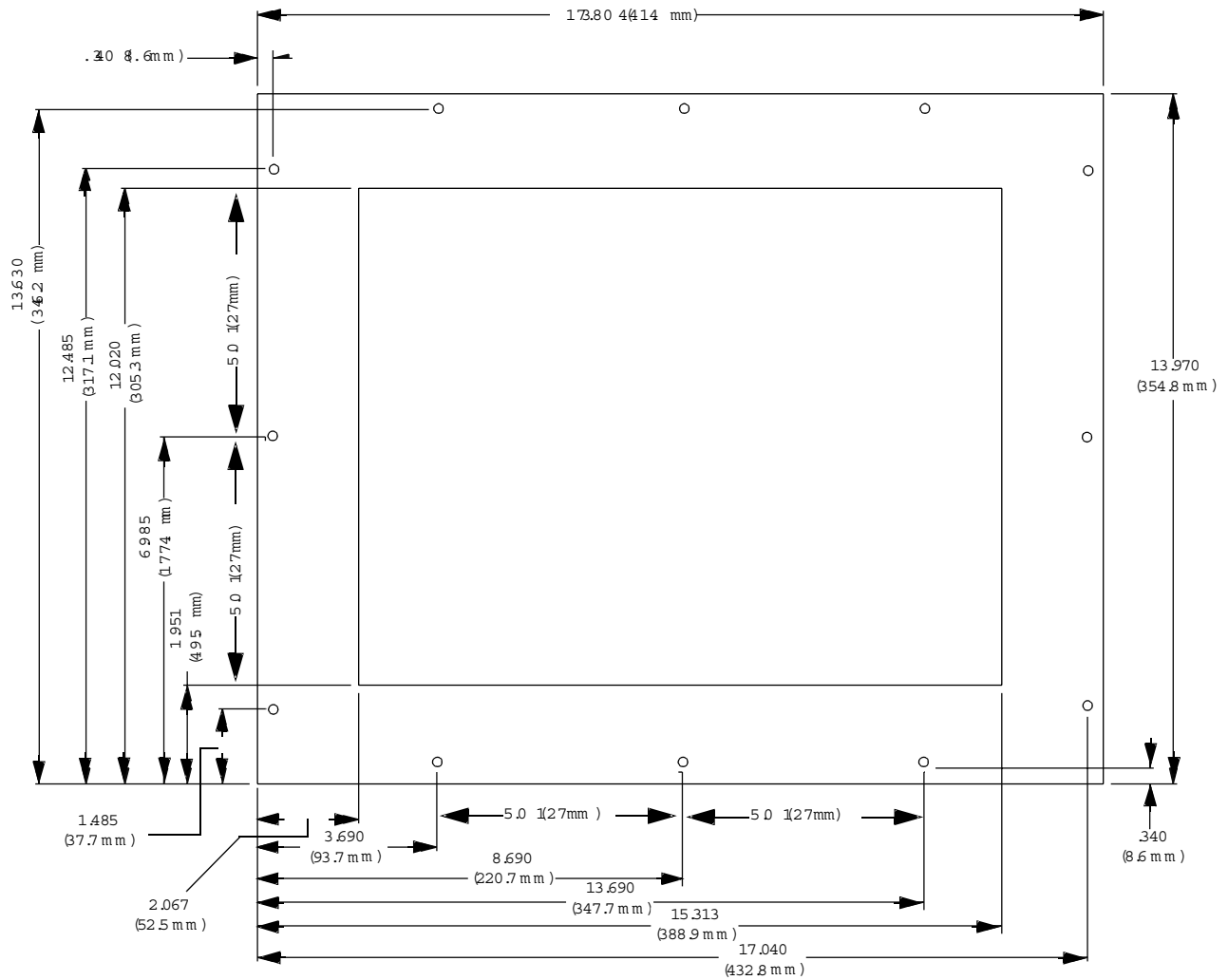

Mounting the Cutout Adapter and New Terminal

Follow the steps below to mount the new terminal into the existing PanelView 1400e Touch Screen terminal cutout.

Disconnect the Terminal

1. Disconnect power at the source and remove the power cord from the PanelView 1400e terminal.
2. Disconnect all communication cables from the PanelView 1400e terminal.

ATTENTION



Make sure that the power cord of the PanelView 1400e terminal is disconnected, and that all cables have been disconnected from the rear of the terminal.

Remove the Existing Terminal

1. Remove the mounting clips or nuts and washers that secure the PanelView 1400e terminal to the panel.
2. Slide the existing terminal out from the terminal.

Attach the Cutout Adapter Plate to the Panel

1. Align the cutout adapter to the desired position.
2. Push the cutout adapter plate onto the panel until the gasket material is flush with the front of the panel.
3. Using the 12 nuts with flat washers, fasten the cutout adapter plate to the panel.
Tighten the washers until the gasket is slightly compressed.
4. Using the torque wrench, tighten the nuts to no more than 10 inch-pounds (a torque of 10 inch-pounds attains a NEMA Type 4X rating). Do not over-tighten.

Attach the Terminal to Adapter Plate

1. Insert the new touch screen terminal into the adapter plate cutout until the terminal gasket is flush with the front of the adapter plate.
2. Install the mounting clips according to the Installation Instructions of the new terminal. The ends of the clips slide into the slots on the terminal.

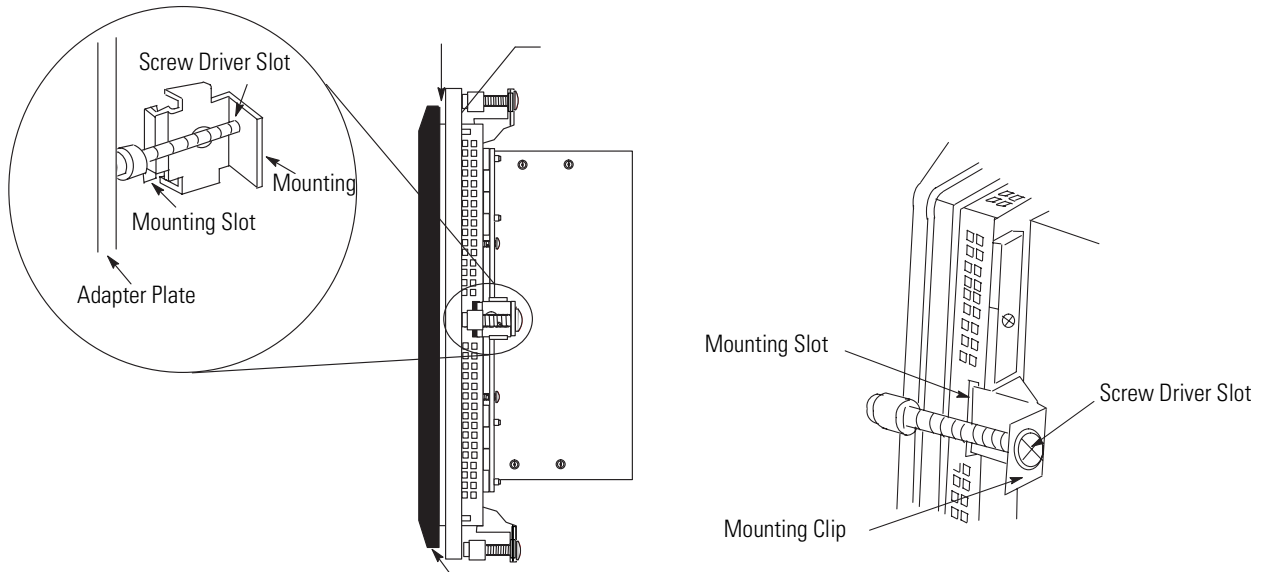

3. Tighten the screws on the mounting clips by hand until the gasket seal contacts the mounting surface uniformly.
4. Using the torque wrench, tighten the screws on the mounting clips to the torque rating provided in the Installation Instructions of the new terminal. Do not overtighten.

ATTENTION



Tighten mounting clips to the proper torque to provide a proper seal and to prevent potential damage to the terminal. Allen-Bradley assumes no responsibility for water or chemical damage to the terminal or other equipment within the enclosure because of improper installation.

The new touch screen terminal is now ready for operation.

PanelView, PanelView Plus, Allen-Bradley, and Rockwell Automation are trademarks of Rockwell Automation, Inc.

Trademarks not belonging to Rockwell Automation are property of their respective companies.

www.rockwellautomation.com

Power, Control and Information Solutions Headquarters

Americas: Rockwell Automation, 1201 South Second Street, Milwaukee, WI 53204-2496 USA, Tel: (1) 414.382.2000, Fax: (1) 414.382.4444

Europe/Middle East/Africa: Rockwell Automation, Vorstlaan/Boulevard du Souverain 36, 1170 Brussels, Belgium, Tel: (32) 2 663 0600, Fax: (32) 2 663 0640

Asia Pacific: Rockwell Automation, Level 14, Core F, Cyberport 3, 100 Cyberport Road, Hong Kong, Tel: (852) 2887 4788, Fax: (852) 2508 1846