



## Bridge Fan and Capacitor Replacement (for 3000A 1395 DC Drives)

### Contents

This document shows how to remove and replace a bridge fan and fan capacitor in a 3000A 1395 DC drive.



**ATTENTION:** Both the bridge fan **and** the fan capacitor must be replaced together when installing this kit. Equipment failure or equipment damage may result if only one item is replaced.

### What This Kit Contains

Using the table below, verify that you have received the appropriate items in your kit:

For this part:	You should receive this quantity:
bridge fan	1
capacitor (25 $\mu$ F)	1
mounting bracket	1

### Other Items Needed

Before you begin, be sure you also have the following:

- Tools you will need for:
  - Measuring voltages (multimeter)
  - Removing and fastening screws (slotted screwdriver, ratchet with extension, 3/8" socket)
  - Torquing screws (torque wrench for 20 lb-ft / 27 N-m)
  - Drilling holes (drill with 1/8" bit)
- Documentation:
  - Your drive system schematics
  - Publication 1395-5.40, *Bulletin 1395 Digital DC Drive–User Manual*
  - Publication 2361-5.01, *Bulletin 1395 Digital DC Drive in Bulletin 2361 Motor Control Center for Drive Systems–User Manual*

## Safety Precautions

The following general precautions apply when servicing drives:



---

**ATTENTION:** Only those familiar with the drive system, the products used in the system, and the associated machinery should plan or implement the installation, startup, and future maintenance of the system. Failure to comply can result in personal injury and/or equipment damage.

**ATTENTION:** Verify that all sources of AC and DC power are deenergized and locked out or tagged out in accordance with the requirements of ANSI/NFPA 70E, Part II.

**ATTENTION:** The system may contain stored energy devices. To avoid the hazard of electrical shock, verify that all voltage on capacitors has been discharged before attempting to service, repair, or remove a drive system or its components. You should only attempt the procedures in this manual if you are qualified to do so and are familiar with solid-state control equipment and the safety procedures in publication NFPA 70E.

**ATTENTION:** When servicing any unit, do not drop any nuts, bolts, washers, etc. inside the unit, as they may cause a short circuit on power up.

**ATTENTION:** This drive system contains ESD (Electrostatic Discharge) sensitive parts and assemblies. Static control precautions are required when installing, testing, or repairing this assembly. Component damage can result if ESD control procedures are not followed. If you are not familiar with static control procedures, refer to Allen-Bradley publication 8000-4.5.2, *Guarding Against Electrostatic Damage* or any other applicable ESD protection handbook.

---

## Special Instructions

**Important:** You will need to reuse parts that are removed from the unit. Place parts, in the order removed, on a clean surface.

## Preliminary Steps

Before replacing the bridge fan and fan capacitor, shut off the drive power. Wait five minutes for all voltage to discharge. Open the bridge bay door and remove all Lexan™ guards that shield the bridge fan.

*Note: The bridge fan **and** fan capacitor must be replaced together.*

## Removing the Bridge Fan

1. Using a meter, test the voltage across the three phases of the AC line.



**ATTENTION:** If there is any voltage present, remove the source of the voltage. Check for voltages again before proceeding to the next step.

2. Remove the air filter from the fan inlet cover.
3. Remove the bolts which secure the support beam and take the beam out (see Figure 1).
4. Remove the fan inlet cover screws (as shown in Figure 1). Remove the cover from the assembly.
5. Disconnect the power connector for the fan.
6. Remove the four screws from the fan mounting bracket (as shown in Figure 1).
7. Remove the four screws which attach the fan to the bracket.

**Figure 1**  
Replacing the Bridge Fan

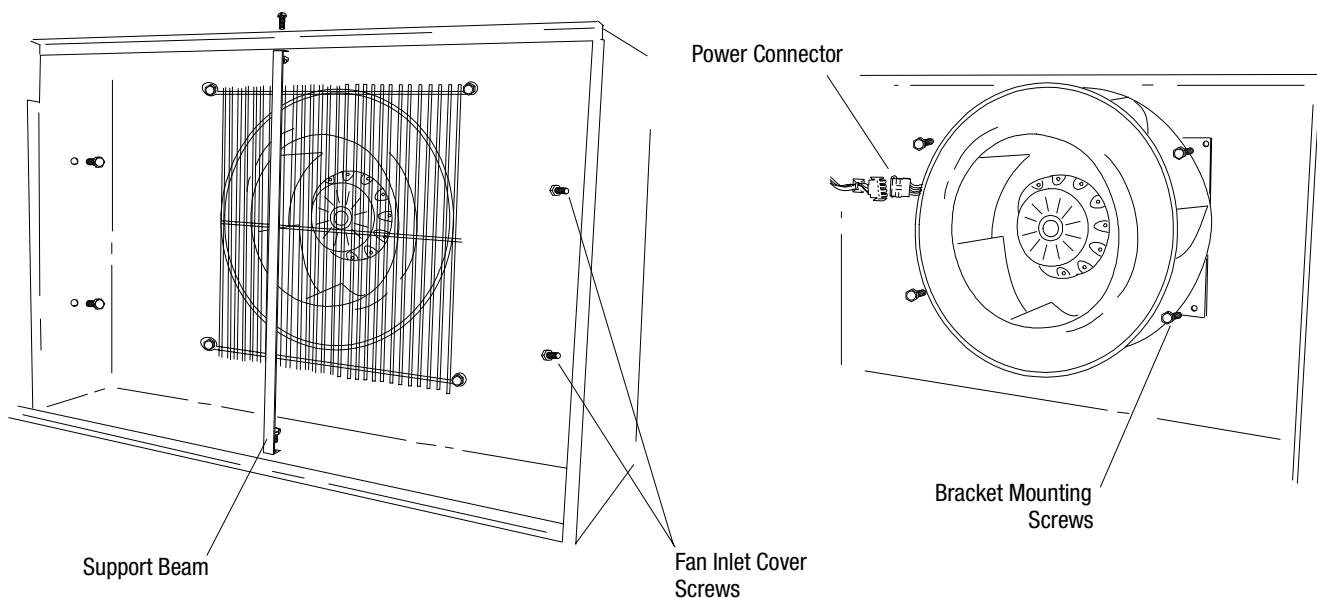

## Replacing the Capacitor

After removing the bridge fan, use the following steps to replace the fan capacitor.

1. Disconnect the leads from the fan capacitor (see Figure 2).
2. Remove the screws which secure the capacitor bracket. Remove the bracket and capacitor from the unit.
3. If the existing bracket is larger than the bracket included in the kit, perform the following steps:
  - a. Mark the point where the new hole is to be placed (see Figure 2). You may use the new bracket in the kit as a guide.
  - b. Drill a 1/8" hole at the point indicated in Figure 2.
  - c. Vacuum any metal shavings from inside or outside of the unit. Do not use compressed air.
4. Using the new bracket in the kit, secure the new capacitor into the unit.
5. Connect the leads to the fan capacitor as shown in Figure 2.
6. Insert the air filter into the fan inlet cover.

**Figure 2**  
Replacing the Capacitor

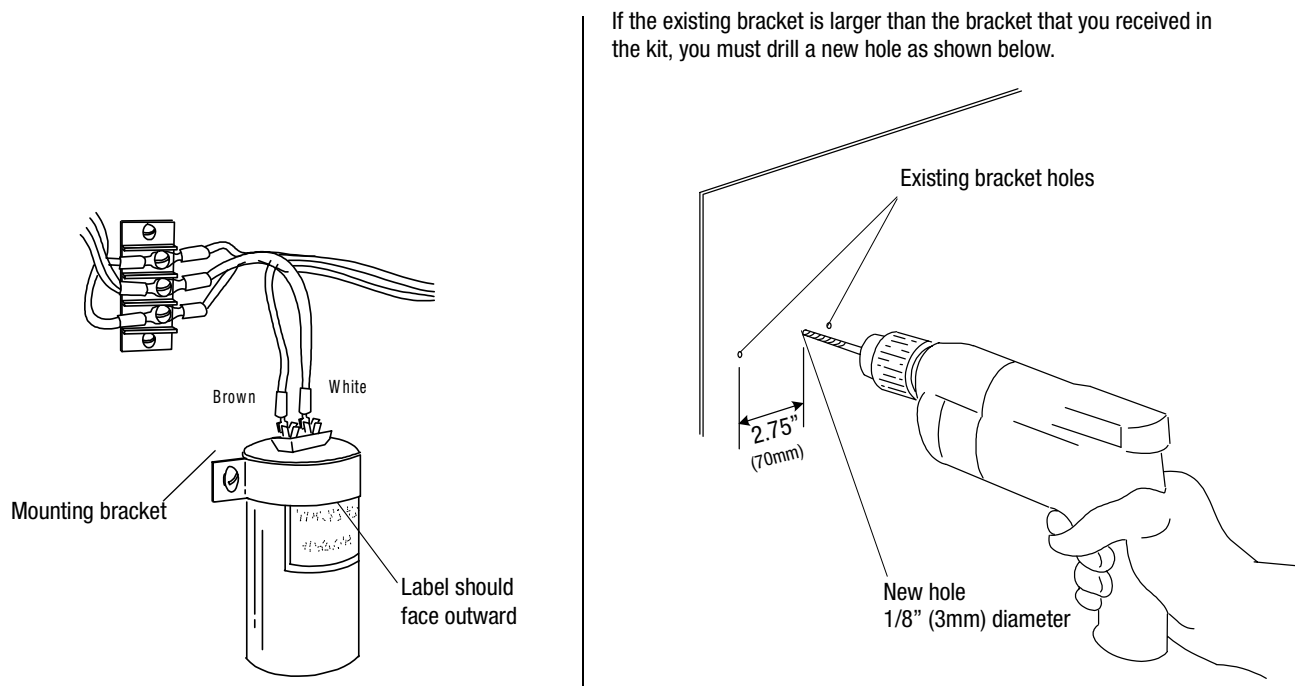

## Installing the New Bridge Fan

1. Secure the new bridge fan to the mounting bracket with its four mounting screws. Torque to 20 lb-ft (27 N-m).
2. Secure the mounting bracket to the unit with its four mounting screws. Torque to 20 lb-ft (27 N-m).
3. Connect the fan power connector as shown in Figure 1.
4. Install the fan inlet cover and secure it to the unit with its four mounting screws. Torque to 20 lb-ft (27 N-m).
5. Install the support beam and secure it to the unit with its two mounting screws (see Figure 1). Torque to 20 lb-ft (27 N-m).

## Concluding Steps

After installing the new bridge fan and bridge fan capacitor, replace all Lexan shielding to the unit. Check the unit for any tools or debris, then close the bay door. Discard any damaged parts according to your company procedures and local ordinances.

Lexan is a trademark of General Electric Corporation

---

**Reach us now at [www.rockwellautomation.com](http://www.rockwellautomation.com)**

Wherever you need us, Rockwell Automation brings together leading brands in industrial automation including Allen-Bradley controls, Reliance Electric power transmission products, Dodge mechanical power transmission components, and Rockwell Software. Rockwell Automation's unique, flexible approach to helping customers achieve a competitive advantage is supported by thousands of authorized partners, distributors and system integrators around the world.



**Americas Headquarters**, 1201 South Second Street, Milwaukee, WI 53204, USA, Tel: (1) 414 382-2000, Fax: (1) 414 382-4444  
**European Headquarters SA/NV**, avenue Herrmann Debroux, 46, 1160 Brussels, Belgium, Tel: (32) 2 663 06 00, Fax: (32) 2 663 06 40  
**Asia Pacific Headquarters**, 27/F Citicorp Centre, 18 Whitfield Road, Causeway Bay, Hong Kong, Tel: (852) 2887 4788, Fax: (852) 2508 1846

**Rockwell  
Automation**

Publication 2361-5.29 April 1999  
Supersedes Publication 2361-5.16 - June 1998

PN 192463  
Copyright 1999 of Rockwell International Corporation. Printed in the USA