

Armature SCR Replacement (for 3000A 1395 Drives)

Contents

This document shows how to remove and replace armature SCRs in a 3000A 1395 DC drive.

What This Kit Contains

Using the table below, verify that you have received the appropriate items in your kit:

For this part:	You should receive this quantity:
silicon-controlled rectifier (SCR)	2
bottle of silicone oil	1

Other Items Needed

Before you begin, be sure you also have the following:

- Tools needed for:
 - Removing, tightening, and torquing nuts and bolts (ratchet with extension, 3/8", 9/16", and 1" sockets, torque wrench for 50 lb-in and 25 lb-ft)
 - Loosening and tightening screws (slotted screwdriver)
 - Testing for voltage (multimeter)
- Documentation:
 - Your drive system schematics
 - Publication 1395-5.40, *Bulletin 1395 Digital DC Drive—User Manual*
 - Publication 2361-5.01, *Bulletin 1395 Digital DC Drive in Bulletin 2361 Motor Control Center for Drive Systems—User Manual*

Safety Precautions

The following general precautions apply when working on drives:



ATTENTION: Only those familiar with the drive system, the products used in the system, and the associated machinery should plan or implement the installation, startup, and future maintenance of the system. Failure to comply can result in personal injury and/or equipment damage.

ATTENTION: Verify that all sources of AC and DC power are deenergized and locked out or tagged out in accordance with the requirements of ANSI/NFPA 70E, Part II.

ATTENTION: The system may contain stored energy devices. To avoid the hazard of electrical shock, verify that all voltage on capacitors has been discharged before attempting to service, repair, or remove a drive system or its components. You should only attempt the procedures in this manual if you are qualified to do so and are familiar with solid-state control equipment and the safety procedures in publication NFPA 70E.

ATTENTION: When servicing any unit, do not drop any nuts, bolts, washers, etc. inside the unit, as they may cause a short circuit on power up.

ATTENTION: This drive system contains ESD (Electrostatic Discharge) sensitive parts and assemblies. Static control precautions are required when installing, testing, or repairing this assembly. Component damage can result if ESD control procedures are not followed. If you are not familiar with static control procedures, refer to Rockwell Automation publication 8000-4.5.2, *Guarding Against Electrostatic Damage* or any other applicable ESD protection handbook.

Special Instructions

Important: You will need to reuse parts that are removed from the drive. Place parts, in the order removed, on a clean surface.

Important: Some washers, such as clamp and Belleville washers, have only one correct orientation.

Preliminary Steps

Before replacing the armature SCRs, shut off the drive power, wait five minutes for the voltage to discharge, open the bridge bay door, and remove the Lexan™ shielding.

Removing the Heatpipe Assembly

1. Using a voltmeter, test the voltage across the three phases, then across the heatpipe assembly components (including the SCRs).



ATTENTION: If there is any voltage present, remove the source of the voltage and check for voltages again before proceeding to the next step.

2. Unplug the SCR leads from all the armature-pulse transformer boards. (For SD3100 drives, tag all the SCR leads and disconnect them from the pulse-gate amplifier boards.)
3. Remove the armature-pulse transformer board panel by releasing the black latches on the left and right sides of the panel.
4. Disconnect the three thermal switches and remove the wiring from the mounting clips.
5. Remove the two bolts which connect the assembly to the output busbar.
6. Remove the two bolts which connect the center heatpipe to the incoming AC busbar.
7. Remove the two bolts from the top of the assembly where the Glastic™ shroud is mounted to the back plane.



ATTENTION: The heatpipe assembly weighs about 75 lbs. Take the proper precautions (adhere to your company material handling procedures) when removing the assembly to prevent personal injury and damage to the equipment.

8. Lift the assembly out from the drive.

Figure 1
Removing the Heatpipe Assembly

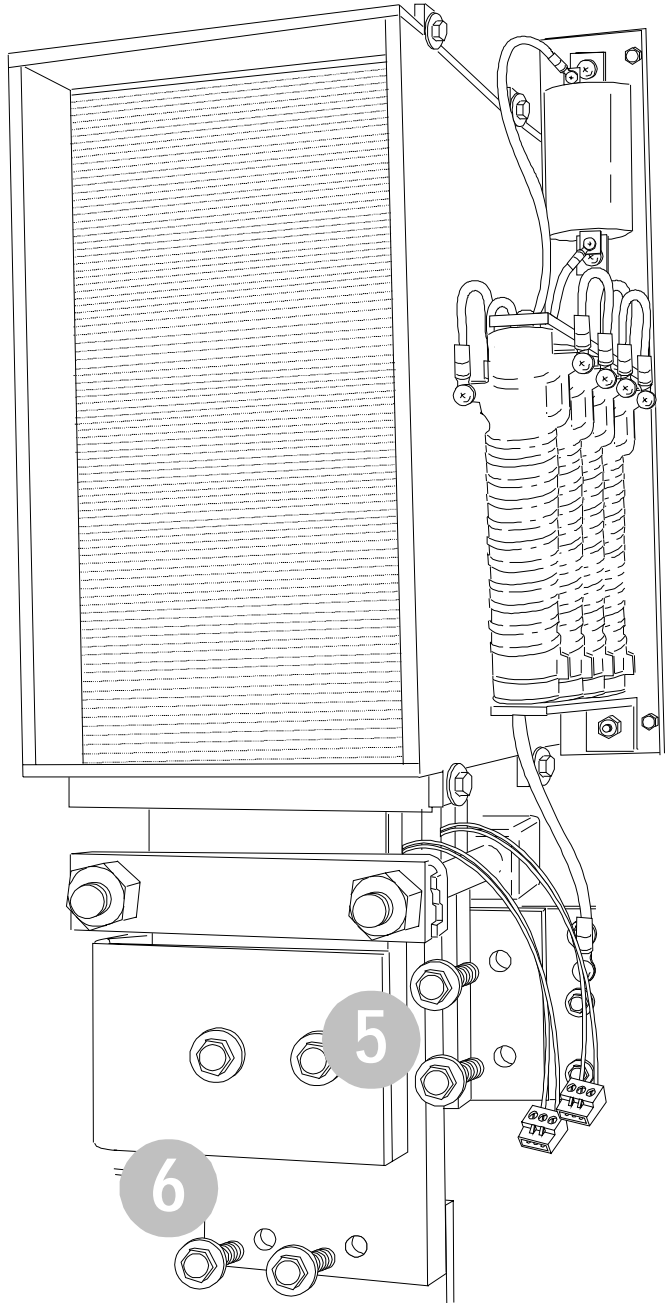
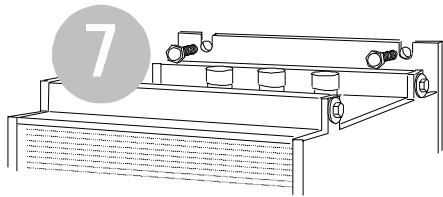
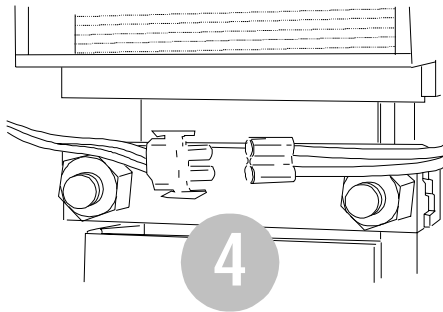
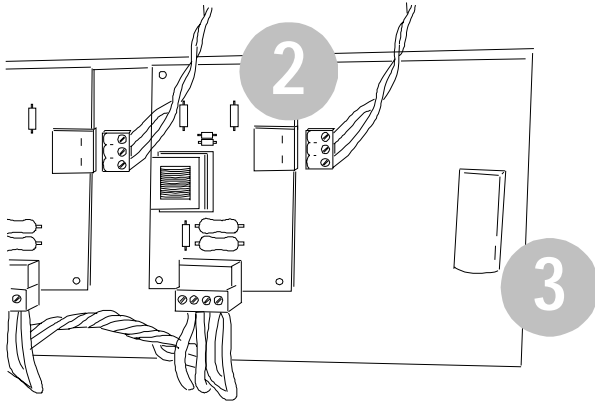

Removing the SCRs

Set the heatpipe assembly on a solid surface and remove the SCRs with the following procedures:

1. Remove the SCR leads from the armature-pulse transformer board connectors (not necessary for SD3100 drives).
2. Remove the two bolts from the left side of the heatpipe pole-face (these bolts connect the U-shaped output busbar on the assembly).
3. Remove the four screws from either side of the Glastic frame. Remove the Glastic sides, bottom, top, and brackets from the assembly.
4. Remove the two clamp nuts and lift the front spring assembly from the clamp.
5. Remove the SCRs to be changed (noting the orientation).

Figure 2
Disassembling The Heatpipe Assembly

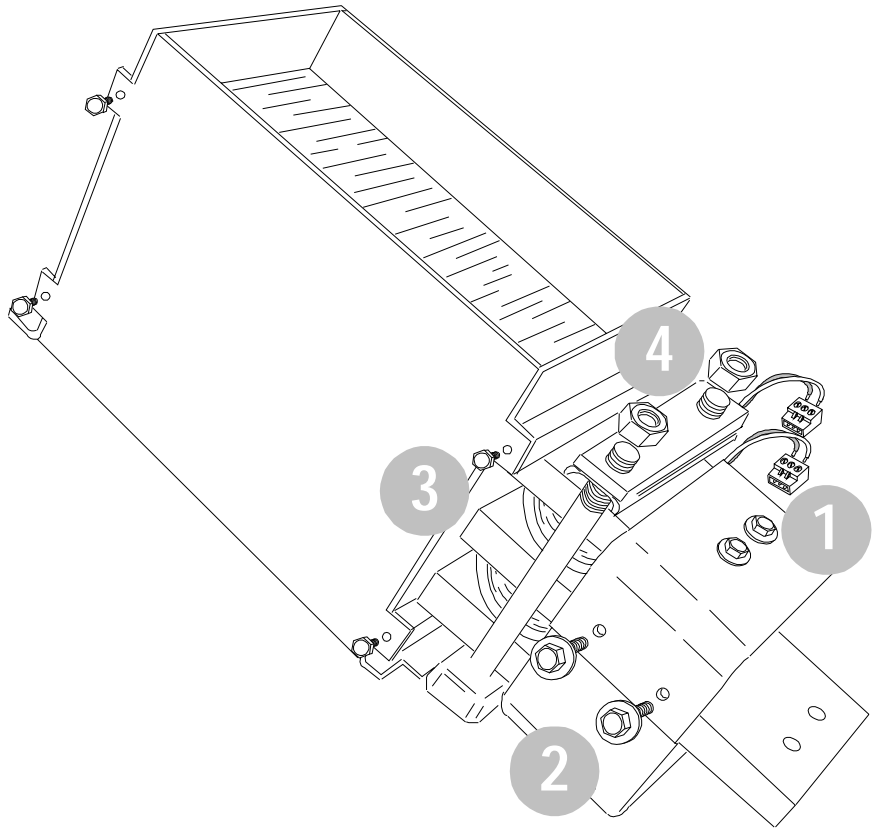

Replacing the SCRs



ATTENTION: The heatpipe assembly weighs about 75 lbs. Take the proper precautions (adhere to your company material handling procedures) when lifting the assembly to prevent personal injury and damage to the equipment.

1. Connect the armature-pulse transformer board connectors to the SCR leads (SD3100 drives will need to have pulse-gate amplifier board connectors crimped onto the SCR leads).

1395 Drives

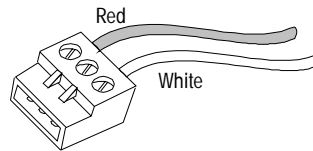

SD3100 Drives

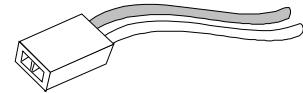

2. Apply silicone oil to the contact surfaces of the SCR.
3. Place the SCR, orienting it properly, and fit the roll pins into the SCR indentations (take care not to damage the SCR). The gate leads should extend out the right side (see the leads illustrated in Figure 1).



ATTENTION: Ensure that the SCRs are installed with the proper polarity. Improper installation will result in damage to the power bridge and may damage other externally connected equipment.

4. Replace the front spring assembly onto the clamp, replace the clamp washers, and screw on the clamp nuts.
5. Replace the Glastic frame and screw in the mounting bolts. Torque to 50 lb-in.
6. Secure the U-shape output busbar, replacing the two bolts and torquing them to 25 lb-ft.
7. Torque the spring assembly to 10,000 lb-ft (10 on spring indicator).

Figure 3
SCR Orientation (Positive)

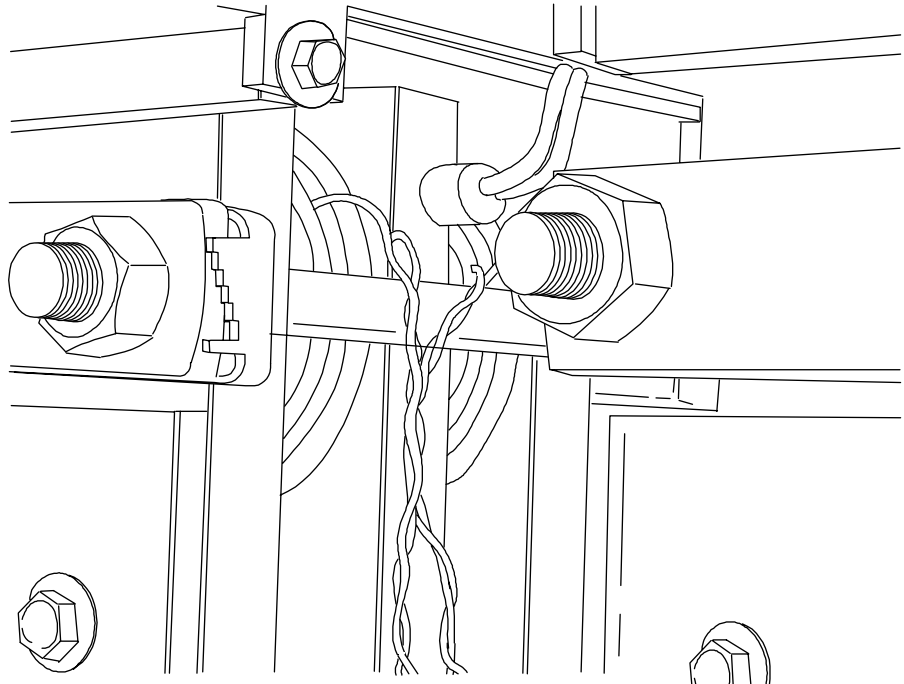

Replacing the Heatpipe Assembly

1. Lift the assembly into the drive. Take care not to damage the assembly.
2. Replace the two bolts to the top of the assembly, mounting the Glastic to the drive.
3. Connect the three thermal switches into their ports and clip the wires into the brackets.
4. Screw in the two bolts which connect the center heatpipe to the incoming AC busbar. Torque to 25 lb-ft.
5. Screw in the two bolts which connect the assembly to the output busbar. Torque to 25 lb-ft.
6. Mount the armature-pulse transformer board panel, securing with the black latches on the left and right sides of the panel.
7. Connect all the SCR leads to the respective armature-pulse transformer boards. (For SD3100 drives, connect all the SCR leads to the pulse-gate amplifier boards).
8. Verify that the SCRs are connected to the proper boards. The red leads should connect to terminals labeled R, and the white leads should connect to terminals labeled W.

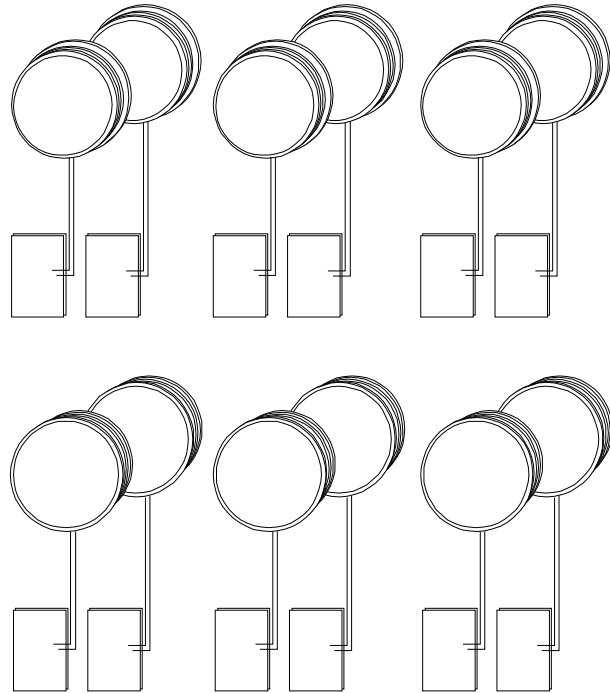

Concluding Steps

After installing the assembly, replace all Lexan shielding and secure the bay door. Dispose of old parts according to your company procedures and local ordinances.

Lexan is a trademark of General Electric Corp.
Glastic is a trademark of Glastic, Inc.



Rockwell Automation helps its customers receive a superior return on their investment by bringing together leading brands in industrial automation, creating a broad spectrum of easy-to-integrate products. These are supported by local technical resources available worldwide, a global network of system solutions providers, and the advanced technology resources of Rockwell.

Worldwide representation.



Argentina • Australia • Austria • Bahrain • Belgium • Bolivia • Brazil • Bulgaria • Canada • Chile • China, People's Republic of • Colombia • Costa Rica • Croatia • Cyprus • Czech Republic • Denmark • Dominican Republic • Ecuador • Egypt • El Salvador • Finland • France • Germany • Ghana • Greece • Guatemala • Honduras • Hong Kong • Hungary • Iceland • India • Indonesia • Iran • Ireland • Israel • Italy • Jamaica • Japan • Jordan • Korea • Kuwait • Lebanon • Macau • Malaysia • Malta • Mexico • Morocco • The Netherlands • New Zealand • Nigeria • Norway • Oman • Pakistan • Panama • Peru • Philippines • Poland • Portugal • Puerto Rico • Qatar • Romania • Russia • Saudi Arabia • Singapore • Slovakia • Slovenia • South Africa, Republic of • Spain • Sweden • Switzerland • Taiwan • Thailand • Trinidad • Tunisia • Turkey • United Arab Emirates • United Kingdom • United States • Uruguay • Venezuela

Rockwell Automation Headquarters, 1201 South Second Street, Milwaukee, WI 53204 USA, Tel: (1) 414 382-2000, Fax: (1) 414 382-4444

Rockwell Automation European Headquarters SA/NV, avenue Hermann Debrouxlaan, 46, 1160 Brussels, Belgium, Tel: (32) 2 663 06 00, Fax: (32) 2 663 06 40

Rockwell Automation Asia Pacific Headquarters, 27/F Citicorp Centre, 18 Whitfield Road, Causeway Bay, Hong Kong, Tel: (852) 2887 4788, Fax: (852) 2508 1846