

## 24V DC Power Supply Replacement (for 1250, 1650, and 3000A 1395 DC Drives)

### Contents

This document shows how to remove and replace a 24V DC power supply for a 1250, 1650, or 3000A 1395 DC drive.

### What This Kit Contains

Using the table below, verify that you have received the appropriate items in your kit:

<b>For this part:</b>	<b>You should receive this quantity:</b>
power supply	1

### Other Items Needed

Before you begin, be sure you also have the following:

- Tools needed for:
  - Removing, loosening, and tightening screws (slotted and Phillips screwdrivers)
  - Test for voltages (multimeter)
- Documentation:
  - Your drive system schematics
  - Publication 1395-5.40, *Bulletin 1395 Digital DC Drive—User Manual*
  - Publication 2361-5.01, *Bulletin 1395 Digital DC Drive in Bulletin 2361 Motor Control Center for Drive Systems—User Manual*

## Safety Precautions

The following general precautions apply when working on drives:

---



**ATTENTION:** Only those familiar with the drive system, the products used in the system, and the associated machinery should plan or implement the installation, startup, and future maintenance of the system. Failure to comply can result in personal injury and/or equipment damage.

**ATTENTION:** Verify that all sources of AC and DC power are deenergized and locked out or tagged out in accordance with the requirements of ANSI/NFPA 70E, Part II.

**ATTENTION:** The system may contain stored energy devices. To avoid the hazard of electrical shock, verify that all voltage on capacitors has been discharged before attempting to service, repair, or remove a drive system or its components. You should only attempt the procedures in this manual if you are qualified to do so and are familiar with solid-state control equipment and the safety procedures in publication NFPA 70E.

**ATTENTION:** When servicing any unit, do not drop any nuts, bolts, washers, etc. inside the unit, as they may cause a short circuit on power up.

**ATTENTION:** This drive system contains ESD (Electrostatic Discharge) sensitive parts and assemblies. Static control precautions are required when installing, testing, or repairing this assembly. Component damage can result if ESD control procedures are not followed. If you are not familiar with static control procedures, refer to Rockwell Automation publication 8000-4.5.2, *Guarding Against Electrostatic Damage* or any other applicable ESD protection handbook.

---

## Special Instructions

**Important:** You will need to reuse parts that are removed from the drive. Place parts, in the order removed, on a clean surface.

**Important:** Some washers, such as clamp and Belleville washers, have only one correct orientation.

## Preliminary Steps

Before replacing the power supply, shut off the drive power, wait five minutes for the voltage to discharge, open the disconnect bay door, and remove the Lexan™ shielding.

## Removing the Power Supply

1. With a voltmeter, test the voltage across the three phases, then across the power supply terminals.



**ATTENTION:** If there is any voltage present, remove the source of the voltage and check for voltages again before proceeding to the next step.

2. Remove the input and output leads from the bottom side of the power supply (while the flip-down panel is closed).
3. Remove the two bottom mounting screws.
4. Open the flip-down panel by loosening the two set screws.
5. Remove the two top mounting screws and remove the power supply.

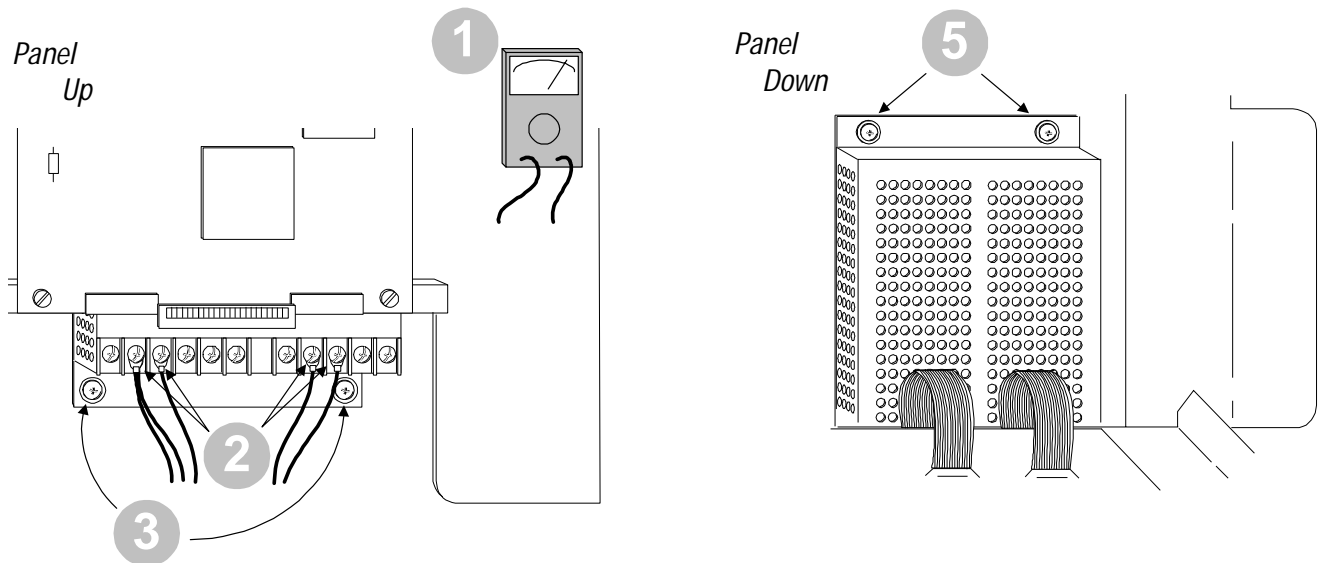

## Installing the Power Supply

1. Slide the new power supply into place and screw in the two top mounting screws.
2. Raise and secure the flip-down panel with the two set screws.
3. Screw in the two bottom mounting screws.
4. Verify that the following terminals are jumpered together:
  - terminals 7 and 8
  - terminals 9 and 10
5. Connect the input and output leads to the respective terminals as follows:

**Note:** Failure to properly connect the wires to the power supply will result in damage to the power supply and/or to the drive.

- Connect red wire, A9(L1), and black wire, A2-L1, to terminal 1 on the supply
- Connect white wire, A9(N2), to terminal 2 on the power supply
- Connect black wire, A9(-V8), to terminal 8 on the power supply
- Connect black wire, A9(+V9), to terminal 9 on the power supply

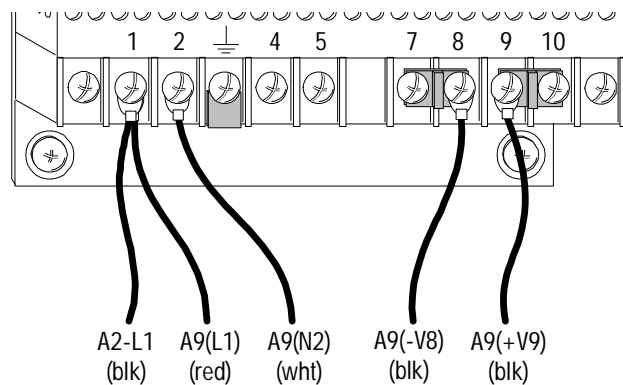

## Concluding Steps

After installing the power supply, replace all Lexan shielding and secure the disconnect bay door. Dispose of old parts according to your company procedures and local ordinances.

Lexan is a trademark of General Electric Corp.



Rockwell Automation helps its customers receive a superior return on their investment by bringing together leading brands in industrial automation, creating a broad spectrum of easy-to-integrate products. These are supported by local technical resources available worldwide, a global network of system solutions providers, and the advanced technology resources of Rockwell.

## Worldwide representation.



Argentina • Australia • Austria • Bahrain • Belgium • Bolivia • Brazil • Bulgaria • Canada • Chile • China, People's Republic of • Colombia • Costa Rica • Croatia • Cyprus • Czech Republic • Denmark • Dominican Republic • Ecuador • Egypt • El Salvador • Finland • France • Germany • Ghana • Greece • Guatemala • Honduras • Hong Kong • Hungary • Iceland • India • Indonesia • Iran • Ireland • Israel • Italy • Jamaica • Japan • Jordan • Korea • Kuwait • Lebanon • Macau • Malaysia • Malta • Mexico • Morocco • The Netherlands • New Zealand • Nigeria • Norway • Oman • Pakistan • Panama • Peru • Philippines • Poland • Portugal • Puerto Rico • Qatar • Romania • Russia • Saudi Arabia • Singapore • Slovakia • Slovenia • South Africa, Republic of • Spain • Sweden • Switzerland • Taiwan • Thailand • Trinidad • Tunisia • Turkey • United Arab Emirates • United Kingdom • United States • Uruguay • Venezuela

Rockwell Automation Headquarters, 1201 South Second Street, Milwaukee, WI 53204 USA, Tel: (1) 414 382-2000, Fax: (1) 414 382-4444

Rockwell Automation European Headquarters SA/NV, avenue Hermann Debrouxlaan, 46, 1160 Brussels, Belgium, Tel: (32) 2 663 06 00, Fax: (32) 2 663 06 40

Rockwell Automation Asia Pacific Headquarters, 27/F Citicorp Centre, 18 Whitfield Road, Causeway Bay, Hong Kong, Tel: (852) 2867 4788, Fax: (852) 2508 1846