

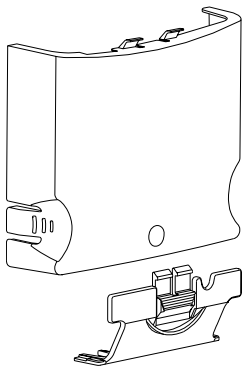

PowerFlex 4/40/40P Replacement Cover  
Ersatz-Frontdeckel für PowerFlex 4/40/40P  
Capot de rechange du PowerFlex 4/40/40P  
Coperchio di ricambio PowerFlex 4/40/40P  
Tapa de reemplazo del PowerFlex 4/40/40P  
PowerFlex 4/40/40P vervangdeksel  
Tampa de Reposição do PowerFlex 4/40/40P

**Installation Instructions**  
**Installationsanleitung**  
**Installation**  
**Instalazione**  
**Instalación**  
**Instructies**  
**Instalação**



SK-U1-ACVR1-A1  
SK-U1-ACVR1-B1  
SK-U1-BCVR1-B1  
SK-U1-BCVR1-C1  
SK-U1-DCVR3-B1  
SK-U1-DCVR3-C1

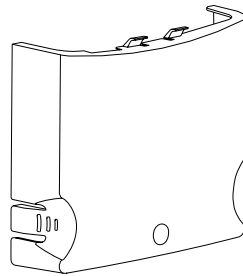

SK-U1-CVR2-A1  
SK-U1-CVR2-B1  
SK-U1-CVR2-C1

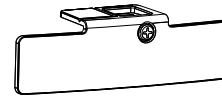

SK-U1-DCVR4-EN

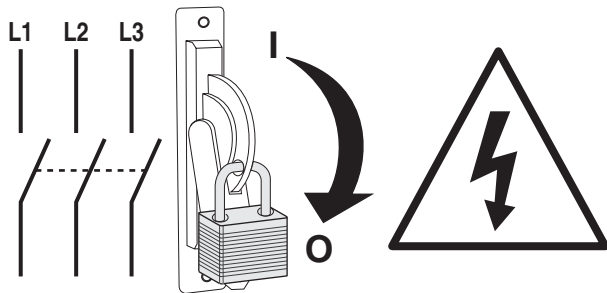

Wait three minutes for capacitors to discharge to safe voltage levels.

Drei Minuten warten, bis die Kondensatoren sich auf eine sichere Spannung entladen haben.

Attendre trois minutes pour s'assurer que les condensateurs se sont déchargés jusqu' à des niveaux de tension sans danger.

Attendere tre minuti affinché i condensatori si scarichino fino a raggiungere un livello di tensione sicuro.

Espere tres minutos a que los condensadores se descar-guen a niveles seguros de tensión; de lo contrario puede sufrir lesiones o incluso la muerte.

Wacht drie minuten zodat de condensators zich kunnen ontladen tot een veilig niveau.

Espere três minutos para que os capacitores descarreguem a níveis seguros de tensão.

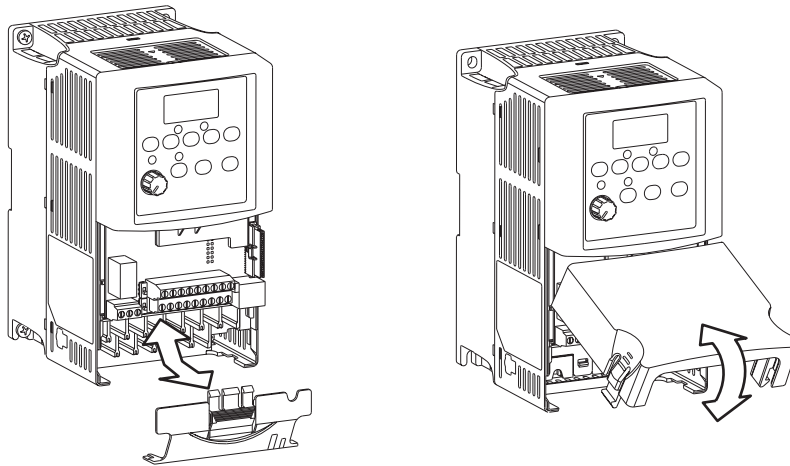

**IP20/Open Type (PowerFlex 40P)**

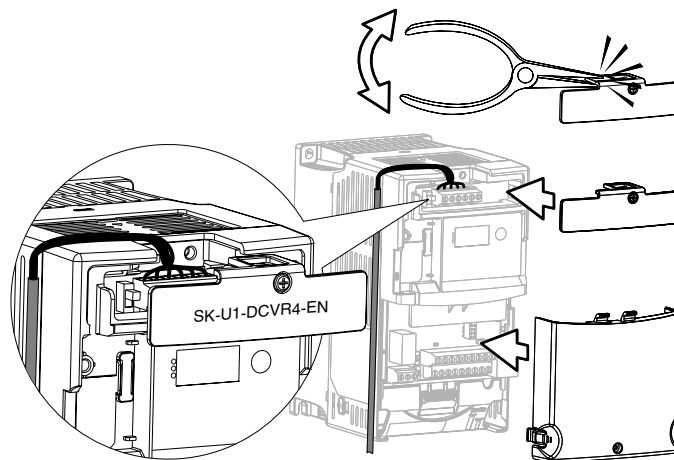

**IP30/NEMA 1/UL Type (PowerFlex 40P)**

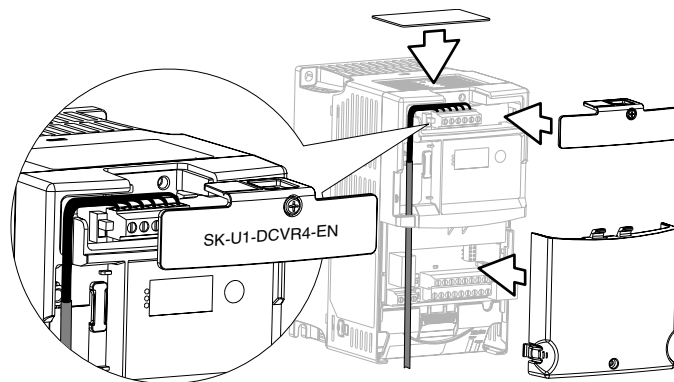

[www.rockwellautomation.com](http://www.rockwellautomation.com)

**Power, Control and Information Solutions Headquarters**

Americas: Rockwell Automation, 1201 South Second Street, Milwaukee, WI 53204-2496 USA, Tel: (1) 414.382.2000, Fax: (1) 414.382.4444

Europe/Middle East/Africa: Rockwell Automation, Vorstlaan/Boulevard du Souverain 36, 1170 Brussels, Belgium, Tel: (32) 2 663 0600, Fax: (32) 2 663 0640

Asia Pacific: Rockwell Automation, Level 14, Core F, Cyberport 3, 100 Cyberport Road, Hong Kong, Tel: (852) 2887 4788, Fax: (852) 2508 1846

Publication 22-IN004B-MU-P – April 2006  
Supersedes 22-IN004A-MU-P

Copyright © 2006 Rockwell Automation, Inc. All rights reserved. Printed in Taiwan.