

PowerFlex Active Front End in IP20 2500 MCC Style Enclosure Frame 10 Bus Splice Kit

Catalog Number	SK-Y1-BUSSPLICE-F10 (for use on right or left side)
Electrical Rating ⁽¹⁾	1250 Amps
Compatible Products	PowerFlex Active Front End Frame 10 in IP20 2500 MCC Style enclosure (Catalog Nos. 20YD460P... , 20YD460W... , 20YF325P... , and 20YF325W...)
Certification ⁽²⁾	

(1) For MCC bus splices.

(2) PowerFlex Active Front End UL listed up to 520 amps DC.

This bus splice kit **must be used** with barrier kit SK-Y1-MCCBARRIER.

Topic	Page
Additional Resources	1
Where the Kit Is Used	2
What the Kit Contains	2
Right-side Connection	3
Left-side Connection	7

Additional Resources

These documents contain more information on related products from Rockwell Automation.

Resource	Description
PowerFlex Active Front End User Manual, publication 20Y-UM001	Provides installation, wiring, operating, and troubleshooting information.
PowerFlex Active Front End—Frame 10 Hardware Service Manual, publication 20Y-TG001	Provides Frame 10 hardware service information and schematic diagrams.

You can view or download publications at <http://www.rockwellautomation.com/literature/>. To order paper copies of technical documentation, contact your local Allen-Bradley distributor or Rockwell Automation sales representative.



ATTENTION: To avoid an electric shock hazard, verify that the voltage on the bus capacitors has discharged completely before performing any work on the Active Front End. After power is removed from the Active Front End, wait 5 minutes for the bus capacitors to discharge. Check the DC bus voltage between the DC+ and DC- terminals, between the DC+ terminal and the chassis, and between the DC- terminal and the chassis. The measured voltage must be zero for all three measurements.



ATTENTION: To guard against personal injury and or equipment damage caused by an ARC Flash, the user must identify the ARC Flash requirements per NFPA 70E.



ATTENTION: If you do not follow ESD control procedures, the PowerFlex Active Front End, which contains electrostatic discharge (ESD) sensitive parts and assemblies, can be damaged. Static control precautions are required when installing, testing, servicing, or repairing the Active Front End. If you are unfamiliar with static control procedures, see Guarding Against Electrostatic Damage, publication 8000-4.5.2, or any other applicable ESD protection handbook.



ATTENTION: An incorrectly applied or installed Active Front End can result in component damage or a reduction in product life. Wiring or application errors such as undersizing the motor, incorrect or inadequate AC supply, or excessive ambient temperatures can result in malfunction of the system.



ATTENTION: The user is responsible for conforming with all applicable local, national, and international codes. Failure to observe this precaution can result in damage to, or destruction of, the equipment.



ATTENTION: Only qualified personnel familiar with the construction and operation of this equipment and the hazards that are involved must plan or implement system installation, startup, and subsequent maintenance. Failure to comply can result in personal injury and/or equipment damage.

Where the Kit Is Used

This kit can be used with only an Active Front End Frame 10 in an IP20 2500 MCC Style enclosure to connect bus bars to an adjacent (right or left side) IP20 2500 MCC Style enclosure with the same bus bar alignment. This provides an in-line common bus system configuration.

What the Kit Contains

SK-Y1-BUSSPLICE-F10 Kit Supplied Parts/Hardware	Part Number	Quantity
PowerFlex 750 High HP Ground Splice	PN-226139	2
MCC Centerline Bus Splice (right or left)	PN-73937	2
Washer, Flat, M10, 10.5 mm ID x 21 mm OD	419064-1SL	16
MCC Bus Clamp Assembly	40319-400-01	8
Hex Nut, Conical Spring Washer, M10 x 13.3 mm	29355-002-01	16
Screw, Hex Flange HD, Taptite, M6 x 20 mm (for PE connection only)	29171-640-02	8

Right-side Connection

To connect the bus bars and attach an enclosure to the right side of the AFE enclosure, follow these steps.

Step 1: Remove power from the AFE.



ATTENTION: To avoid an electric shock hazard, verify that the voltage on the bus capacitors has discharged completely before servicing. Check the DC bus voltage between the +DC and -DC terminals, between the +DC terminal and the chassis, and between the -DC terminal and the chassis. The voltage must be zero for all three measurements.

- a. Turn off and lock out input power.

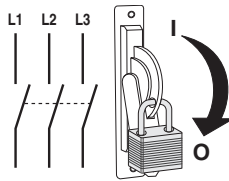

- b. Wait five minutes for bus capacitors to discharge.
- c. Verify that there is no voltage at the AFE input power terminals.
- d. Check the DC bus voltage between the +DC and -DC terminals, between the +DC terminal and the chassis, and between the -DC terminal and the chassis.
The voltage must be zero for all three measurements before proceeding.

Step 2: Remove left side covers from the enclosure being connected to the AFE.

Step 3: Remove the AFE enclosure right side covers to access the bus bars.

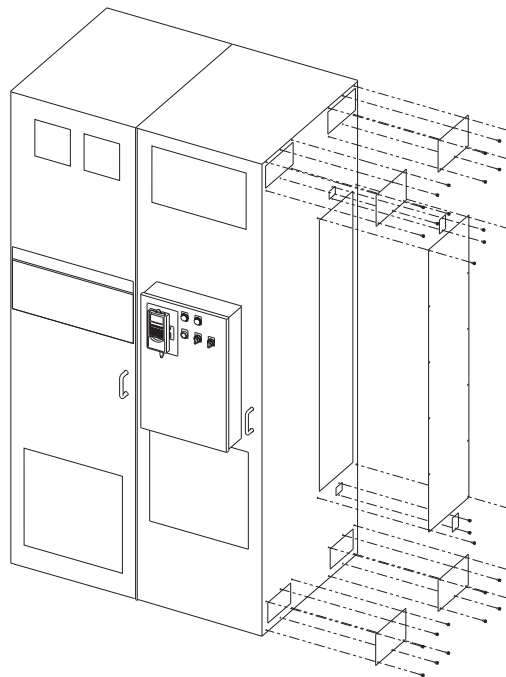

Step 4: Connect the MCC bus and PE ground splices to the AFE bus and ground bars, respectively.

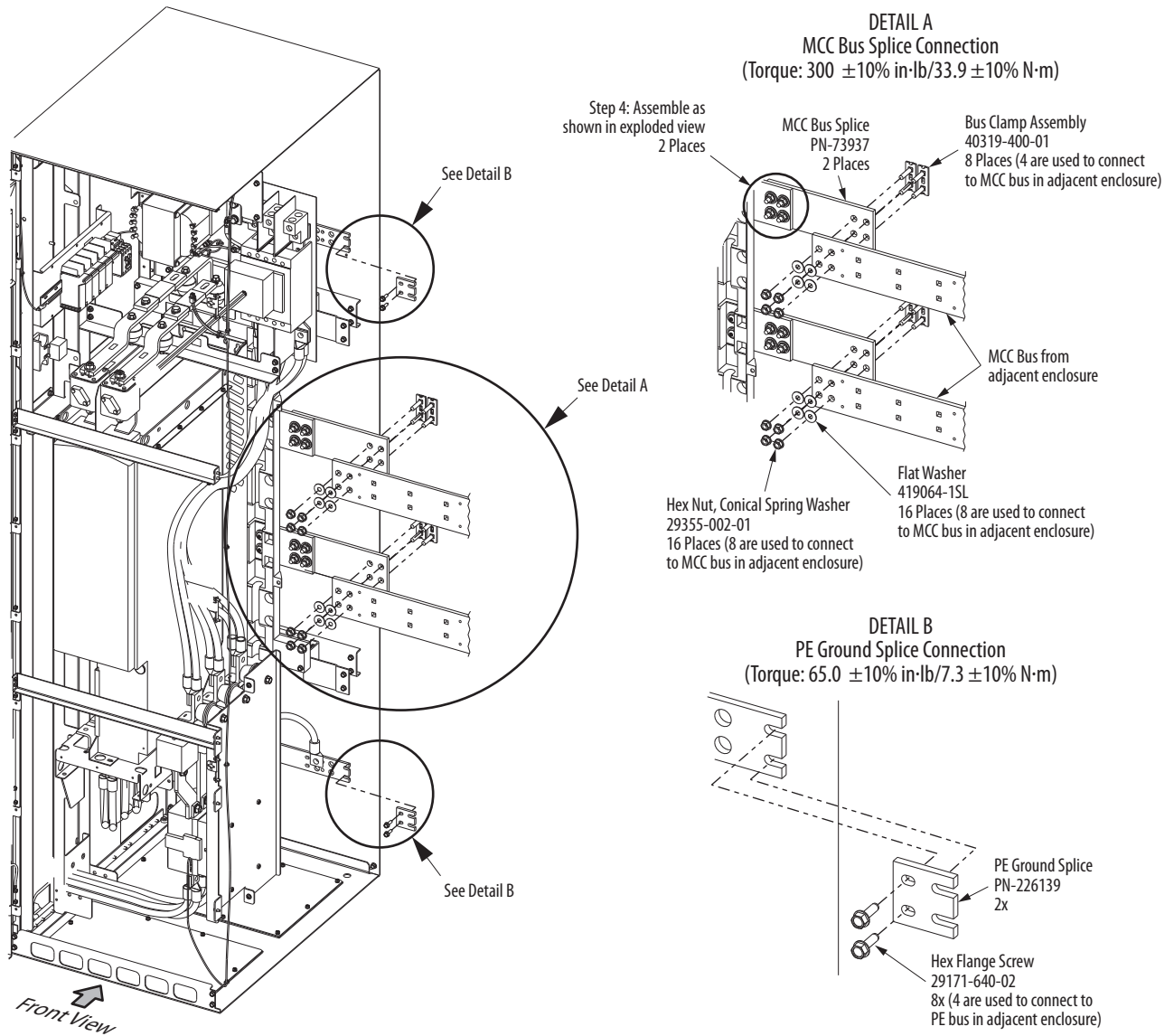

- a. Assemble the MCC bus splices to the AFE horizontal bus bars as shown using the supplied hardware.
Torque to $300 \pm 10\%$ in-lb ($33.9 \pm 10\%$ N•M).
- b. Assemble the PE ground splices to the AFE top and bottom PE ground bus bars using the supplied hardware.
Torque to $65.0 \pm 10\%$ in-lb ($7.3 \pm 10\%$ N•M).

Step 5: Attach both enclosures using the air barrier panels and hardware supplied in the barrier kit (catalog number SK-Y1-MCCBARRIER).



ATTENTION: The barrier kit must be used between the enclosures being attached together to maintain proper air flow within each individual enclosure. Failure to use the barrier kit can result in overheating that can cause equipment damage.

- a. Note the air barrier panel orientations in this figure, position the barrier panels onto the right side of the AFE enclosure, and attach the panels using the supplied hardware (see table below).

Barrier Panels on Right Side of AFE Enclosure

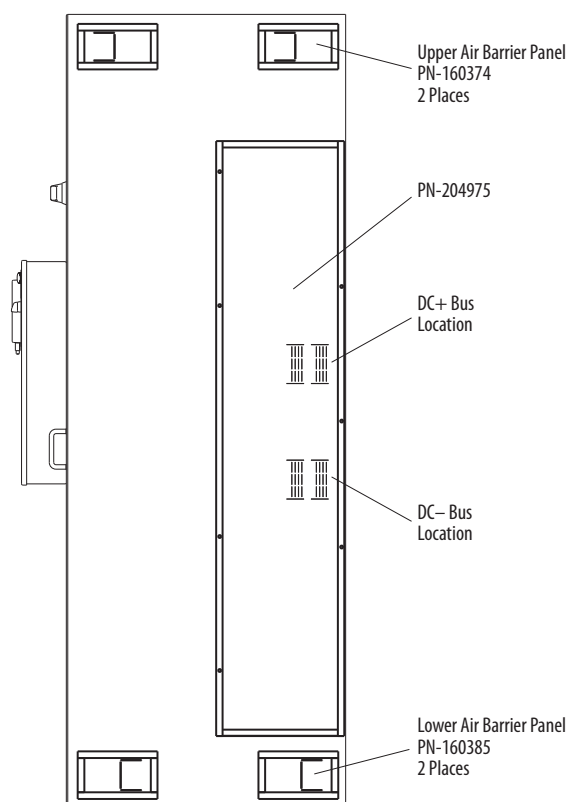

SK-Y1-MCCBARRIER Kit Supplied Parts/Hardware	Part Number	Quantity
PowerFlex 755 High HP Cabinet Barrier Panel, Rear	PN-204975	1
Cabinet Barrier Panel, Upper	PN-160374	2
Cabinet Barrier Panel, Lower	PN-160385	2
Screw, Hex Flange HD, Taptite, M6 x 20 mm	29171-640-02	22

- b. Attach the right side of the AFE enclosure to the left side of the adjacent enclosure.

Torque fasteners to 55.0 in•lb (6.2 N•M) when fastening the enclosures together.

Step 6: Connect the MCC bus and PE ground splices in the AFE enclosure to the bus and ground bars, respectively, in the other enclosure.

- a. Assemble the MCC bus splices to the horizontal bus bars in the other enclosure using the supplied hardware.
Torque to $300 \pm 10\%$ in•lb ($33.9 \pm 10\%$ N•M).
- b. Assemble the PE ground splices to the top and bottom PE ground bus bar connections in the other enclosure using the supplied hardware.
Torque to $65.0 \pm 10\%$ in•lb ($7.3 \pm 10\%$ N•M)

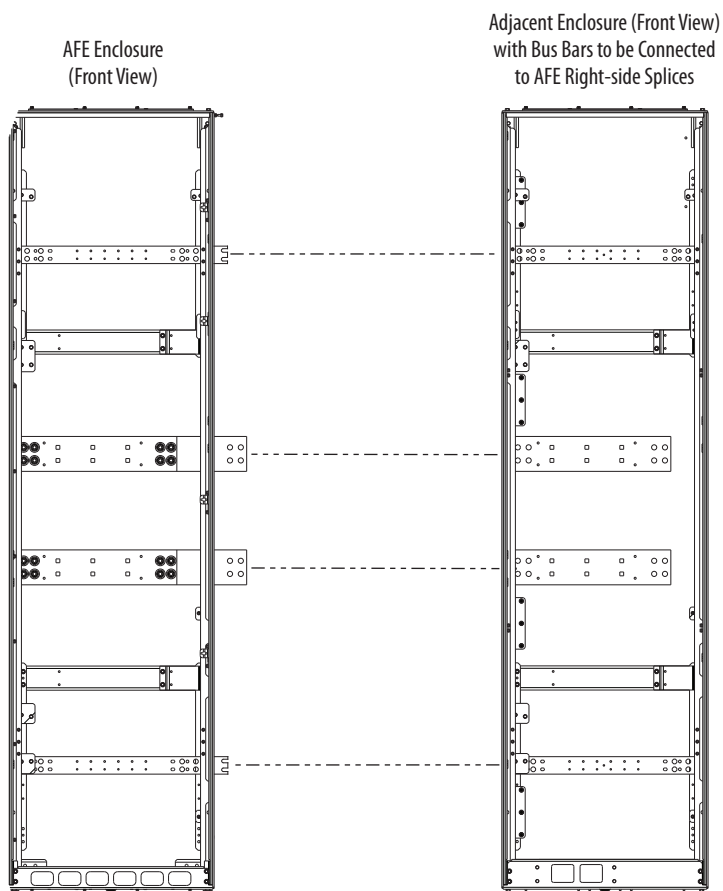

Left-side Connection

To attach the bus bars and enclosure to the left side of the AFE, follow these steps.

Step 1: Remove power from the AFE.



ATTENTION: To avoid an electric shock hazard, verify that the voltage on the bus capacitors has discharged completely before servicing. Check the DC bus voltage between the +DC and -DC terminals, between the +DC terminal and the chassis, and between the -DC terminal and the chassis. The voltage must be zero for all three measurements.

- a. Turn off and lock out input power.

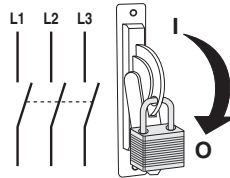

- b. Wait five minutes for bus capacitors to discharge.
- c. Verify that there is no voltage at the AFE input power terminals.
- d. Check the DC bus voltage between the +DC and -DC terminals, between the +DC terminal and the chassis, and between the -DC terminal and the chassis.
The voltage must be zero for all three measurements before proceeding.

Step 2: Remove right side covers from the enclosure being connected to the AFE.

Step 3: Remove the AFE enclosure left side covers to access the bus bars.

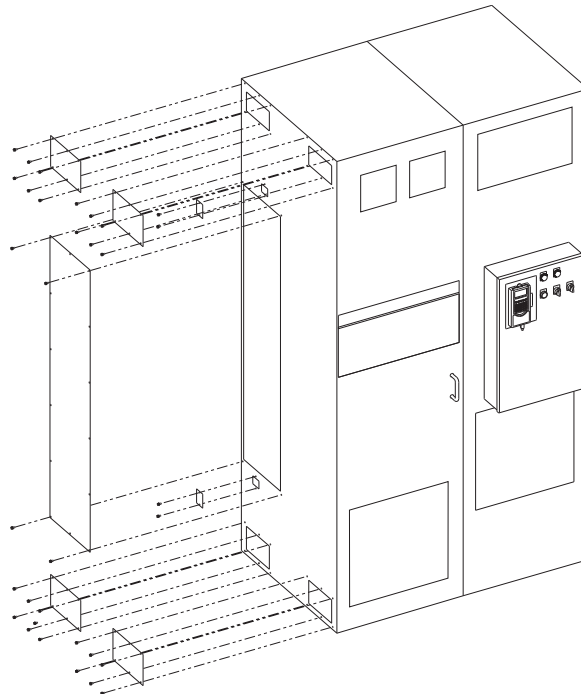

Step 4: Connect the MCC bus and PE ground splices to the AFE bus and ground bus bars, respectively.

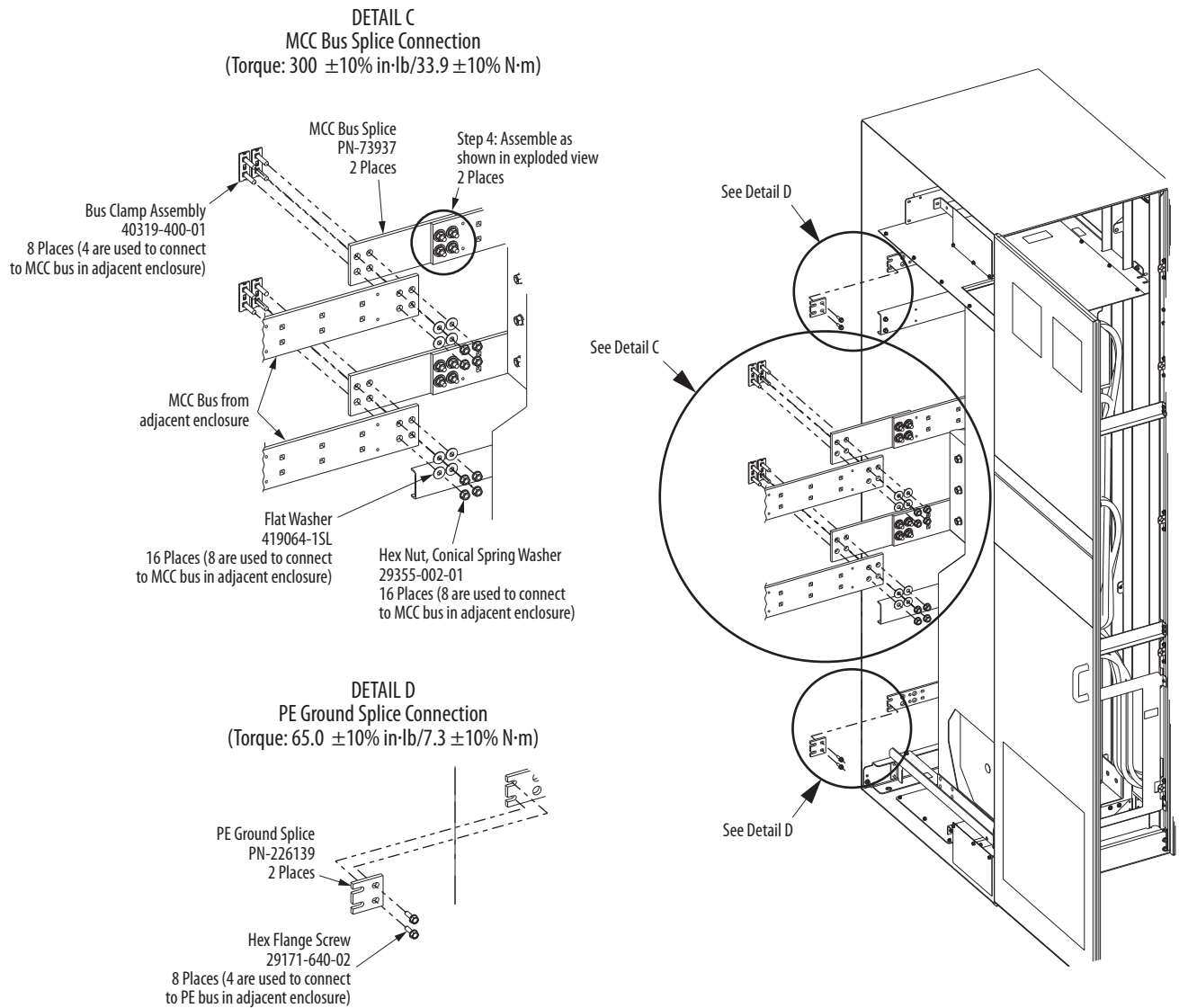

- a. Assemble the MCC bus splices to the AFE horizontal bus bars using the supplied hardware.
Torque to 300 ±10% in•lb (33.9 ±10% N•M).
- b. Assemble the PE ground splices to the AFE top and bottom PE ground bus bars using the supplied hardware.
Torque to 65.0 ±10% in•lb (7.3 ±10% N•M).

Step 5: Attach both enclosures using the air barrier panels and hardware supplied in the barrier kit (catalog number SK-Y1-MCCBARRIER).



ATTENTION: The barrier kit must be used between the enclosures being attached together to maintain proper air flow within each individual enclosure. Failure to use the barrier kit can result in overheating that can cause equipment damage.

- a. Note the air barrier panel orientations in this figure, position the barrier panels onto the left side of the AFE enclosure, and attach the panels using the supplied hardware (see table below).

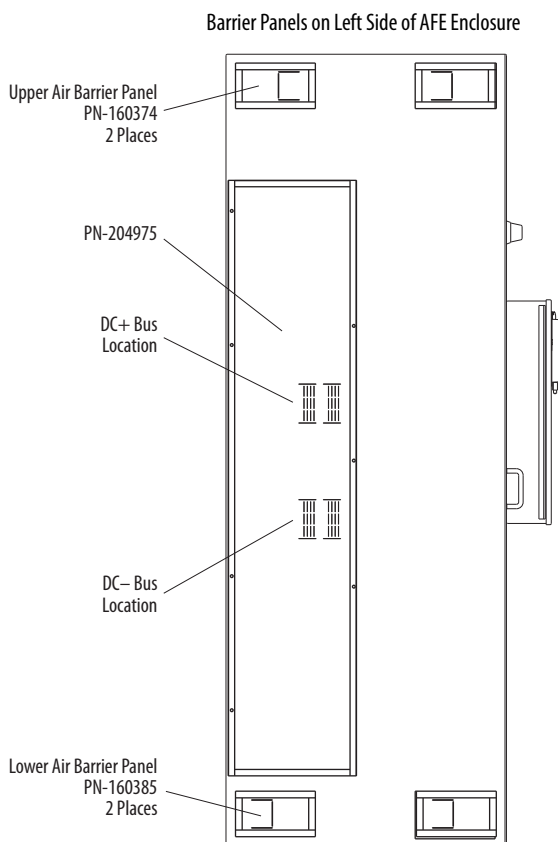

SK-Y1-MCCBARRIER Kit Supplied Parts/Hardware	Part Number	Quantity
PowerFlex 755 High HP Cabinet Barrier Panel, Rear	PN-204975	1
Cabinet Barrier Panel, Upper	PN-160374	2
Cabinet Barrier Panel, Lower	PN-160385	2
Screw, Hex Flange HD, Taptite, M6 x 20 mm	29171-640-02	22

- b. Attach the left side of the AFE enclosure to the right side of the adjacent enclosure.

Torque fasteners to 55.0 in•lb (6.2 N•M) when fastening the enclosures together.

Step 6: Connect the MCC bus and PE ground splices in the AFE enclosure to the bus and ground bars, respectively, in the other enclosure.

- a. Assemble the MCC bus splices to the horizontal bus bars in the other enclosure using the supplied hardware.
Torque to $300 \pm 10\%$ in•lb ($33.9 \pm 10\%$ N•M).
- b. Assemble the PE ground splices to the top and bottom PE ground bus bar connections in the other enclosure using the supplied hardware.
Torque to $65.0 \pm 10\%$ in•lb ($7.3 \pm 10\%$ N•M).

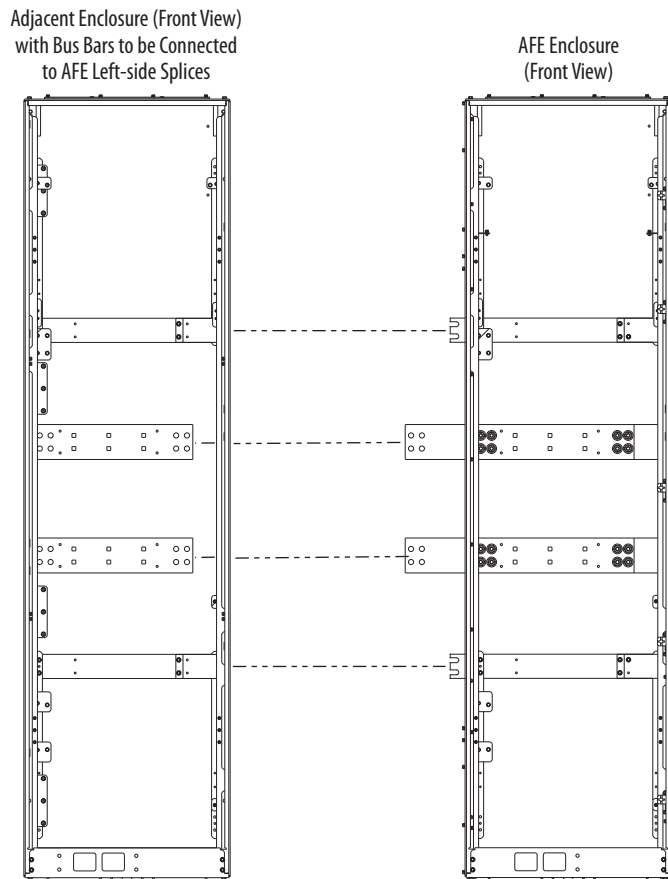

U.S. Allen-Bradley Drives Technical Support - Tel: (1) 262.512.8176, Fax: (1) 262.512.2222, E-mail: support@drives.ra.rockwell.com
Online: www.ab.com/support/abdrives

Allen-Bradley, Rockwell Software, Rockwell Automation, and TechConnect are trademarks of Rockwell Automation, Inc.
Trademarks not belonging to Rockwell Automation are property of their respective companies.

www.rockwellautomation.com

Power, Control and Information Solutions Headquarters

Americas: Rockwell Automation, 1201 South Second Street, Milwaukee, WI 53204-2496 USA, Tel: (1) 414.382.2000, Fax: (1) 414.382.4444
Europe/Middle East/Africa: Rockwell Automation NV, Pegasus Park, De Kleetlaan 12a, 1831 Diegem, Belgium, Tel: (32) 2 663 0600, Fax: (32) 2 663 0640
Asia Pacific: Rockwell Automation, Level 14, Core F, Cyberport 3, 100 Cyberport Road, Hong Kong, Tel: (852) 2887 4788, Fax: (852) 2508 1846