

en Installation instructions E300 Comunication module

- de** Installationsanleitung Kommunikationsmodul E300
- fr** Notice d'installation Module de communication E300
- it** Istruzioni per l'installazione Modulo di comunicazione E300
- zh** 安装说明 E300 通信模块
- es** Instrucciones de instalación Módulo de comunicación E300
- ru** инструкция по установке Коммуникационный модуль E300
- pt** Instruções de instalação E300 módulo de comunicação
- ko** 설치 매뉴얼 E300 통신 모듈



At the end of its life, this equipment should be collected separately from any unsorted municipal waste.

- en ATTENTION! HAZARDOUS VOLTAGE!**
The installation and the operation of this device and any maintenance must be carried out by a qualified person in accordance with specific local standards and safety regulations. Before installing this device, read these operating instructions carefully. Do not touch live parts. To avoid damages to persons and material the devices have to be replaced in case of mechanical and/or electrical damage.
(Follow NFPA 70E requirements).
- de ACHTUNG! GEFÄHRLICHE SPANNUNG!**
Die Installation und der Betrieb dieses Geräts sowie jegliche Wartung müssen von einer qualifizierten Person gemäß den spezifischen örtlichen Normen und Sicherheitsvorschriften durchgeführt werden. Lesen Sie vor der Installation des Geräts diese Betriebsanleitung sorgfältig durch. Aktive Teile dürfen nicht berührt werden. Um Schäden an Personen und Material zu vermeiden, müssen die Geräte bei mechanischen und/oder elektrischen Schäden an den Geräten ersetzt werden.
- fr ATTENTION! TENSION DANGEREUSE!**
L'installation, l'utilisation et la maintenance de ce dispositif doivent être réalisées par du personnel qualifié conformément aux normes et réglementations de sécurité locales. Avant d'installer le dispositif, lisez attentivement ces directives d'utilisation. Ne touchez pas les pièces sous tension. Afin d'éviter les dommages causés aux personnes et aux biens, les dispositifs doivent être remplacés en cas de dommage mécanique et/ou électrique. (Respectez les exigences NFPA 70E).
- it ATTENZIONE! PERICOLO TENSIONE!**
L'installazione e il funzionamento di questo dispositivo e qualsiasi manutenzione devono essere eseguiti da una persona qualificata in conformità con le norme locali e di sicurezza specifiche. Prima di installare questo dispositivo, leggere attentamente queste istruzioni per l'uso. Non toccare le parti in tensione. Per evitare danni a persone e materiali, i dispositivi devono essere sostituiti in caso di danni meccanici e/o elettrici.
- zh 注意! 电压危险!**
本设备的安装和操作以及所有维护工作均必须由合格的人员按照当地的具体标准和安安全守则进行。安装本设备前, 请仔细阅读这些操作说明。请勿触摸带电部分。为了避免人员伤亡和材料损坏, 如果在出现机械和/或电气损坏, 必须更换此设备。

- es ¡ATENCIÓN! ¡VOLTAJE PELIGROSO!**
La instalación y operación de este dispositivo, así como cualquier mantenimiento, debe ser realizado por una persona cualificada de acuerdo con estándares locales y reglamentos de seguridad específicos. Antes de instalar este dispositivo, lea atentamente las instrucciones de uso. No toque piezas bajo tensión. Para evitar daños personales y materiales, los dispositivos deben reemplazarse en caso de fallo mecánico o eléctrico. (Siga los requisitos NFPA 70E).
- ru ВНИМАНИЕ! ОПАСНОЕ НАПРЯЖЕНИЕ!**
Установка и эксплуатация этого устройства, а также любое техническое обслуживание и ремонт должны выполняться квалифицированным специалистом согласно соответствующим местным стандартам и нормам техники безопасности. Перед установкой данного устройства внимательно прочтите настоящую инструкцию по эксплуатации. Не прикасайтесь к токоведущим частям. В случае возникновения механических и/или электрических повреждений необходимо заменять устройства во избежание травматизма персонала и повреждения материальной части.
- pt ATENÇÃO! TENSÃO PERIGOSA!**
A instalação e operação deste dispositivo e qualquer manutenção devem ser feitas por pessoal qualificado, de acordo com as normas locais e regulamentações de segurança. Antes de instalar este dispositivo, leia com atenção as instruções de operação. Não toque em peças energizadas. Para evitar danos a pessoas e materiais, os dispositivos devem ser substituídos em caso de dano mecânico e/ou elétrico.
- ko 주의! 위험한 전압!**
이 장치의 설치 및 작동과 유지 보수는 유자격 직원이 지역 표준 및 안전 규정에 따라 수행해야 합니다. 이 장치를 설치하기 전에 사용자 매뉴얼을 주의 깊게 읽으십시오. 작동 중인 부품에 손을 대지 마십시오. 인적 및 물적 피해를 방지할 수 있도록 기계적 및/또는 전기적 손상이 발생하는 경우에 장치를 교체해야 합니다.

Features - EtherNet (193-ECM-ETR)

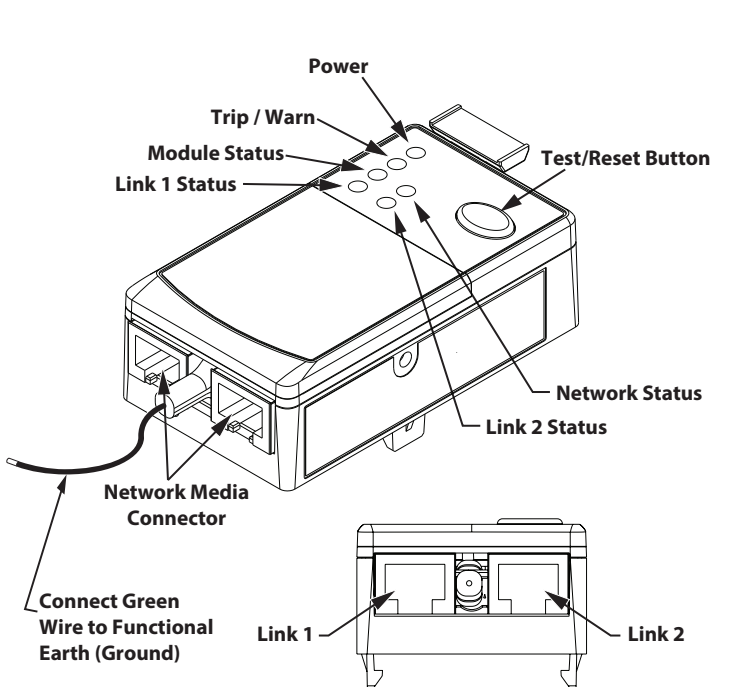

Network Information

- MAC Id
- Serial Number
- Firmware Revision

Node Address

Node Address	Function
001 - 254	Set IP Address to 192.168.1.xxx
255 - 887	Set IP Address via DHCP or use static IP Address
889 - 999	Reset to factory defaults
888	Reset to factory defaults
000	Administration mode

Features - DeviceNet (193-ECM-DNT)

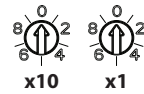
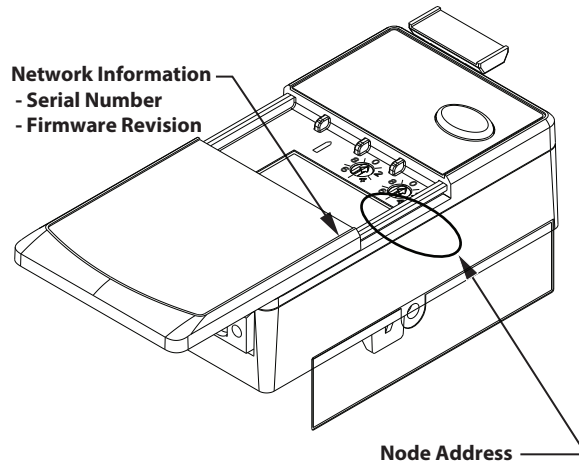
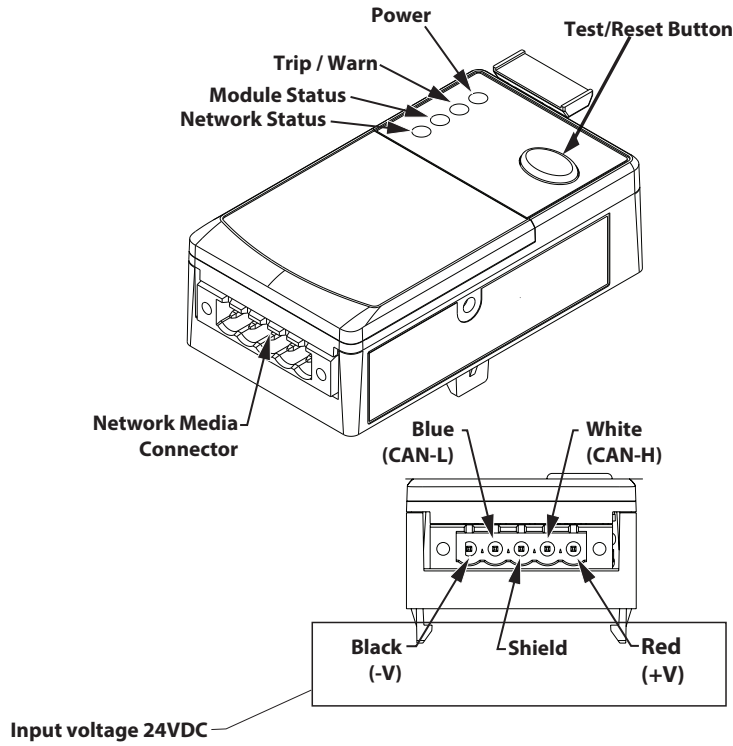

Node Address	Function
00 - 63	Set node address to xx
64 - 76	Software sets node address
78 - 98	Software sets node address
88	Reset to factory defaults
77	Administration mode



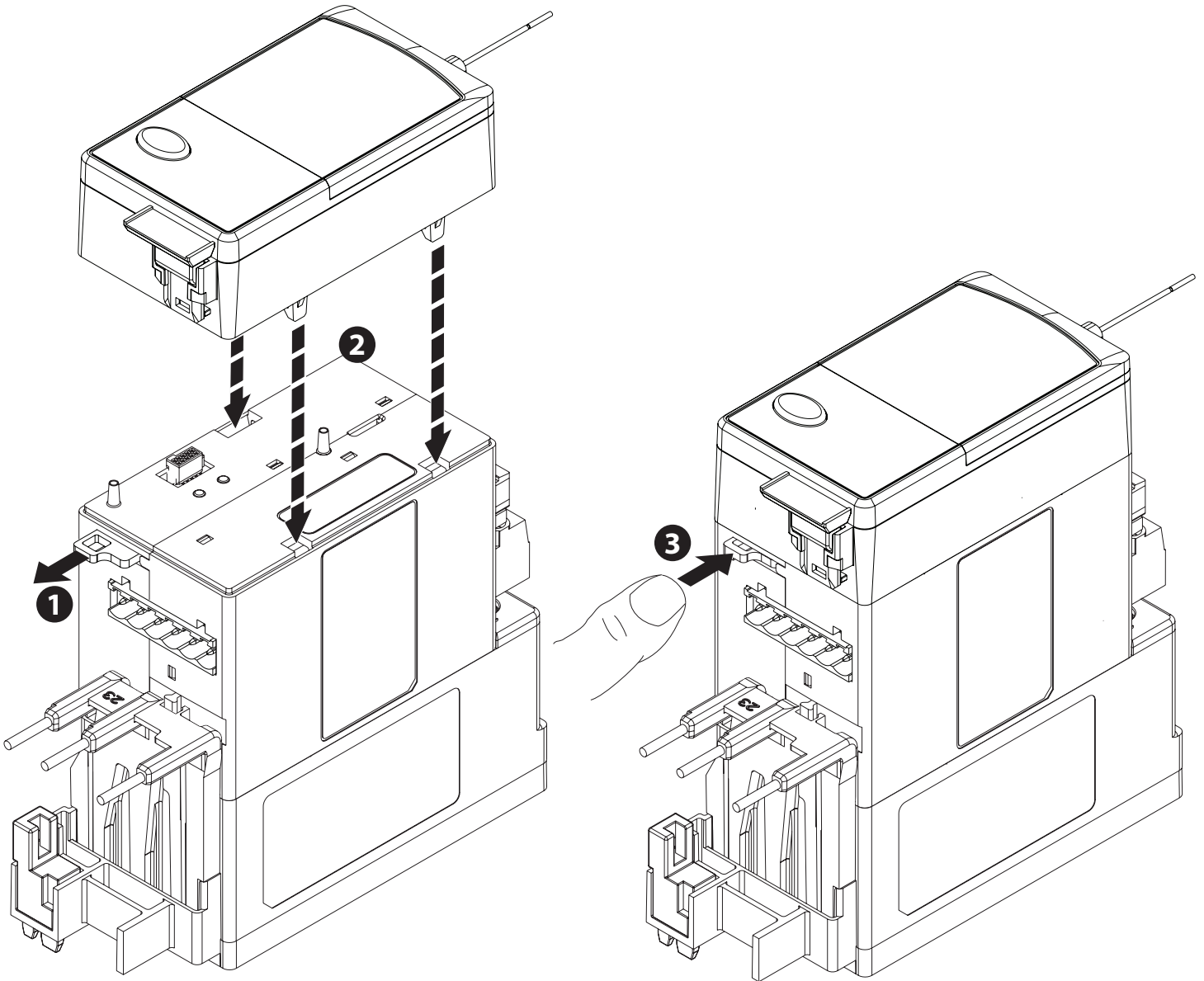

Installation



Recommended Ethernet cables

1585J-M8TBJM-2	RJ45 Straight Male to RJ45 Straight Male, Teal Robotic TPE, Weld Splatter, Flex Rated, 2 m
1585J-M8HBJM-2	RJ45 Straight Male to RJ45 Straight Male, Teal PVC, 600V Rated, 2 m

Custom lengths available up to 99 meters

Connect with us.    

For Technical Support, visit rok.auto/support.

Rockwell Automation maintains current product environmental compliance information on its website at rok.auto/pec.

Product certificates are located in the Rockwell Automation Literature Library: rok.auto/certifications.

Rockwell Otomasyon Ticaret A.Ş., Kar Plaza İş Merkezi E Blok Kat:6 34752 İçerenköy, İstanbul, Tel: +90 (216) 5698400

EEE Yönetmeliğine Uygundur.

rockwellautomation.com

expanding human possibility™

AMERICAS: Rockwell Automation, 1201 South Second Street, Milwaukee, WI 53204-2496 USA, Tel: 414.382.2000, Fax: (1) 414.382.4444

EUROPE/MIDDLE EAST/AFRICA: Rockwell Automation NV, Pegasus Park, De Kleetlan 12a, 1831 Diegem, Belgium, Tel: (32) 2663 0600, Fax: (32) 2663 0640

ASIA PACIFIC: Rockwell Automation, Level 14, Core F, Cyberport 3, 100 Cyberport Road, Hong Kong, Tel: (852) 2887 4788, Fax: (852) 2501846



PN-510353

DIR 10000518535 (Version 02)

Publication 193-IN059C-EN-P - March 2021 | Supersedes Publication 193-IN059B-EN-P - July 2018

Copyright © 2021 Rockwell Automation, Inc. All Rights Reserved. Printed in USA.