



## **Zone Control I/O Cards**

Catalog Numbers 1799-ZCIOB, 1799-D10U10BZC,  
1799-ZCIOV, 1799-D10U10VZC

### **Inside . . .**

<b>For</b>	<b>See page</b>
Important User Information	2
Environment and Enclosure	3
About the Cards	4
Install the Card	5
Set the Node Address	5
Mount the Card	7
Connect the Card	9
Communicate with the Card	13
Configure the Parameters	14
Troubleshoot the Zone Cards	16
Technical Support	18
Specifications	19

## Important User Information

Solid state equipment has operational characteristics differing from those of electromechanical equipment. *Safety Guidelines for the Application, Installation and Maintenance of Solid State Controls* (Publication SGI-1.1 available from your local Rockwell Automation sales office or online at <http://www.literature.rockwellautomation.com>) describes some important differences between solid state equipment and hard-wired electromechanical devices. Because of this difference, and also because of the wide variety of uses for solid state equipment, all persons responsible for applying this equipment must satisfy themselves that each intended application of this equipment is acceptable.





In no event will Rockwell Automation, Inc. be responsible or liable for indirect or consequential damages resulting from the use or application of this equipment.

The examples and diagrams in this manual are included solely for illustrative purposes. Because of the many variables and requirements associated with any particular installation, Rockwell Automation, Inc. cannot assume responsibility or liability for actual use based on the examples and diagrams.

No patent liability is assumed by Rockwell Automation, Inc. with respect to use of information, circuits, equipment, or software described in this manual.

Reproduction of the contents of this manual, in whole or in part, without written permission of Rockwell Automation, Inc., is prohibited.

Throughout this manual, when necessary, we use notes to make you aware of safety considerations.

<b>WARNING</b> 	Identifies information about practices or circumstances that can cause an explosion in a hazardous environment, which may lead to personal injury or death, property damage, or economic loss.
<b>IMPORTANT</b>	Identifies information that is critical for successful application and understanding of the product.
<b>ATTENTION</b> 	Identifies information about practices or circumstances that can lead to personal injury or death, property damage, or economic loss. Attentions help you identify a hazard, avoid a hazard and recognize the consequences.
<b>SHOCK HAZARD</b> 	Labels may be located on or inside the equipment (e.g., drive or motor) to alert people that dangerous voltage may be present.
<b>BURN HAZARD</b> 	Labels may be located on or inside the equipment (e.g., drive or motor) to alert people that surfaces may be dangerous temperatures.

---

## Environment and Enclosure

---

**ATTENTION**

This equipment is intended for use in a Pollution Degree 2 industrial environment, in overvoltage Category II applications (as defined in IEC publication 60664-1), at altitudes up to 2000 meters without derating.

This equipment is considered Group 1, Class A industrial equipment according to IEC/CISPR Publication 11. Without appropriate precautions, there may be potential difficulties ensuring electromagnetic compatibility in other environments due to conducted as well as radiated disturbance.

This equipment is supplied as open type equipment. It must be mounted within an enclosure that is suitably designed for those specific environmental conditions that will be present and appropriately designed to prevent personal injury resulting from accessibility to live parts. The interior of the enclosure must be accessible only by the use of a tool. Subsequent sections of this publication may contain additional information regarding specific enclosure type ratings that are required to comply with certain product safety certifications.

NOTE: See NEMA Standards publication 250 and IEC publication 60529, as applicable, for explanations of the degrees of protection provided by different types of enclosure. Also, see the appropriate sections in this publication, as well as the Allen-Bradley publication 1770-4.1, Industrial Automation Wiring and Grounding Guidelines, for additional installation requirements pertaining to this equipment.

---

## About the Cards

The 1799 Zone Control I/O cards are 20-point I/O cards that communicate via the DeviceNet network. These cards are intended for material handling and other applications. The cards also have Zone Interlocking Protocol (ZIP) capability, which lets the cards communicate directly with each other without hard wiring them together and using a scanner.

These cards have 10 inputs and 10 outputs. Inputs are 24V dc sourcing (PNP) or sinking (NPN). Outputs are self-protected 24V dc sourcing (1799-ZCIOB and -D10U10BZC) or sinking (1799-ZCIOV and -D10U10VZC).

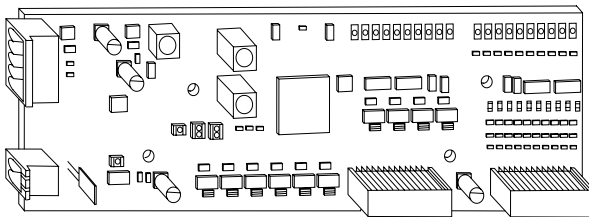

43040

## Parts List

Your package contains:

- One 1799 Zone Control card
- DeviceNet connector
- Auxiliary power connector
- Mounting plate and four mounting screws
- These installation instructions

## Optional Hardware

All mating connectors and mounting hardware must be ordered separately. The following table identifies the different connector and hardware options.

Option	Catalog Number	Third Party Supplier & Part Number
2 DIN rail brackets (4 screws)	1799-BRKD	N/A
2, 12-position, gold-plated I/O mating connectors	1799-12SPCON	Phoenix - FK-MC 0.5/12-ST-2.5AU - 1923432

---

## Install the Card

To install the card:

- Set the node address
- Mount the card (brackets, mounting plate)
- Connect the card (DeviceNet network, auxiliary power, I/O)
- Communicate with your card
- Configure the parameters

More detailed information about each of these steps is in the following procedures.

---

## Prevent Electrostatic Discharge

### ATTENTION



This equipment is sensitive to electrostatic discharge, which can cause internal damage and affect normal operation. Follow these guidelines when you handle this equipment:

- Touch a grounded object to discharge potential static.
- Wear an approved grounding wriststrap.
- Do not touch connectors or pins on component boards.
- Do not touch circuit components inside the equipment.
- If available, use a static-safe workstation.
- When not in use, store the equipment in appropriate static-safe packaging.

---

## Set the Node Address

Valid node addresses are **00** to **63**.

Set the node address using the rotary switches or a DeviceNet configuration tool such as RSNetWorx for DeviceNet software. Setting the switches between **64** and **99** lets the software have address control.

### IMPORTANT

You must use RSNetWorx for DeviceNet software, revision 3.21 or later with the Zone Control I/O cards.

---

Each card is shipped with the node address set to **63** in the card's memory. The rotary switches are set for position **99** at shipment. The switches are located near the center of the card. The two switches are:

- MSD (most significant digit)
- LSD (least significant digit)

To reset the node address, use a small blade screwdriver to rotate the switches. Line up the small arrow on the switch with the number setting you wish to use.

The rotary switches are read only when you apply power to the card. Settings between 64 and 99 cause the card to use the last valid node address stored in the card's memory.

For example, the last setting in memory is 40. If a change is made to 68, and then you apply power to the card, the address will default to 40.

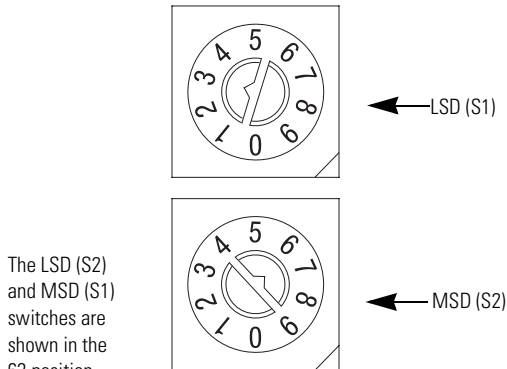

42496

The card is equipped with AutoBaud detect. AutoBaud lets the card detect the communication rate on your DeviceNet network and automatically adjusts to that rate. The card is shipped with AutoBaud enabled.

## Mount the Card

The Zone Control card comes with a mounting plate. You have the option to order the DIN-rail brackets (1799-BRKD) for mounting directly on a DIN rail.

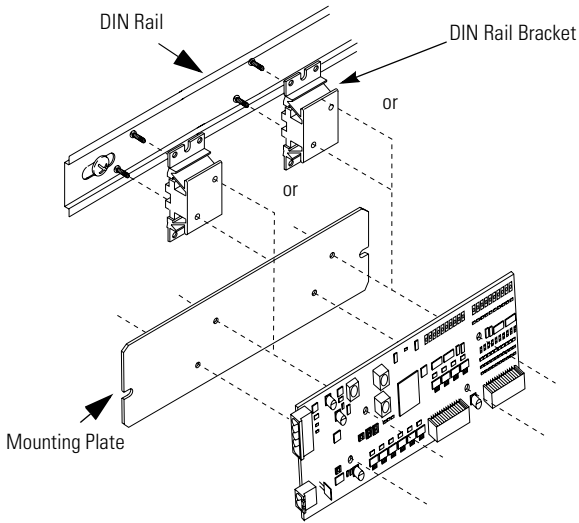

43041

You can also mount the card in an enclosure with pre-tapped holes, which accommodate M3 x 0.5 mm screws.

### Card Dimensions

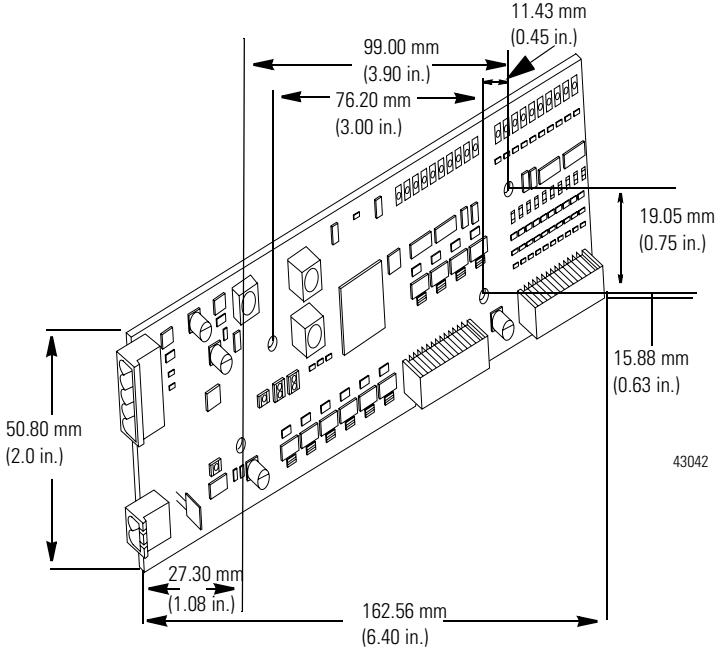

## Connect the Card

Use the following pictures and tables to help you connect the DeviceNet connectors, auxiliary power connectors, and I/O connectors to the card.

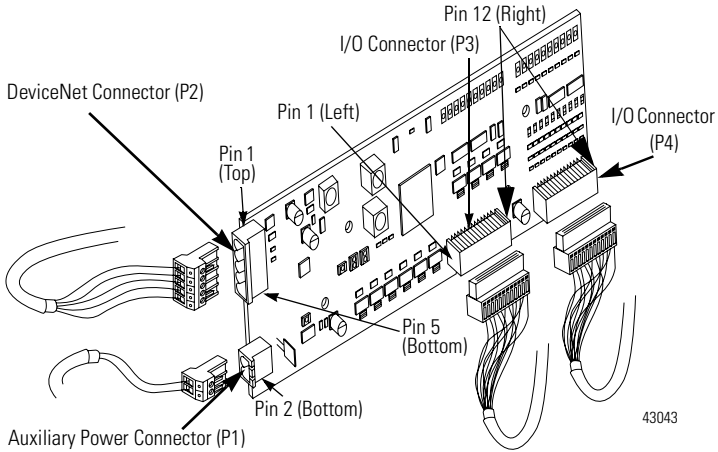

The following table identifies the signal for each 1799-D16U16B and 1799-D16U16BL pin number on the I/O connector.

**P1** Auxiliary Power Connector

Pin	Signal
1	24V dc
2	24V dc Ret

**P2** DeviceNet Connector

Pin	Insulation Colors
1	Black
2	Blue
3	Shield
4	White
5	Red

**P3** I/O Connector

Pin	Signal
1	Output 0
2	Output 1
3	Output 2
4	24V dc Ret
5	Output 3
6	Output 4
7	Output 5
8	Output 6
9	24V dc
10	Output 7
11	Output 8
12	Output 9

**P4** I/O Connector

Pin	Signal
1	Input 0
2	Input 1
3	Input 2
4	In Common
5	Input 3
6	Input 4
7	Input 5
8	Input 6
9	In Common
10	Input 7
11	Input 8
12	Input 9

## Auxiliary Power Specifications

The power source used to supply the auxiliary power to the outputs must be one of the following:

- a 10 to 30V dc Class 2 power supply, or
- a 10 to 30V dc UL Listed or recognized power supply with isolated outputs limited to 200VA in each ungrounded output line.

This condition requires that the card and power source be mounted in a suitable, ultimate enclosure with proper spacings maintained.

## Connect the Field Output Device to the Output Connector (P3)

The 1799-ZCIOB and 1799-D10U10BZC cards have outputs that supply current to your field output device (sourcing outputs). Use the following wiring diagram to connect the outputs on this card.

### *1799-ZCIOB and -D10U10BZC Outputs (Sourcing)*

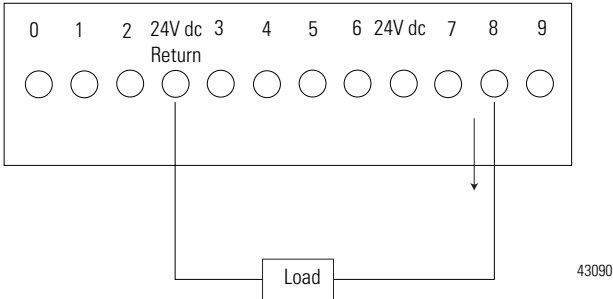

The 1799-ZCIOV and 1799-D10U10VZC cards have outputs that receive current from your field output device (sinking outputs). Use the following wiring diagram to configure the outputs on this card.

### 1799-ZCIOV and -D10U10VZC Outputs (Sinking)

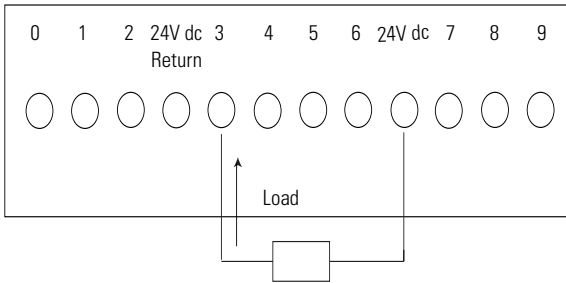

43091

### Connect the Field Input Device to the Input Connector (P4)

The 1799-ZCIOB, 1799-D10U10BZC, 1799-ZCIOV, and 1799-D10U10VZC cards have universal inputs that provide operation with either sourcing or sinking input devices. The universal feature lets you configure the inputs as either all sinking or all sourcing. Use the following wiring diagrams to connect the inputs on the cards.

---

**IMPORTANT**

All field input devices in each group of eight must be of the same type, either sinking or sourcing. The card will not operate if the types are mixed.

---

*Inputs (Sinking)*

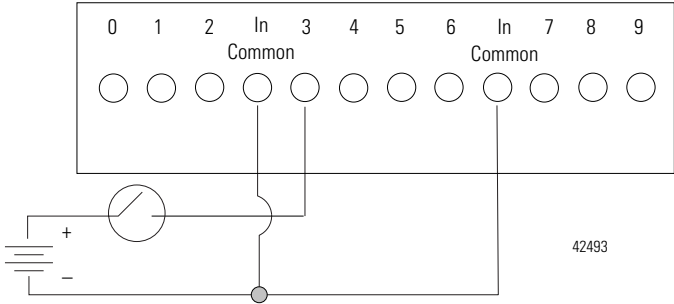

*Inputs (Sourcing)*

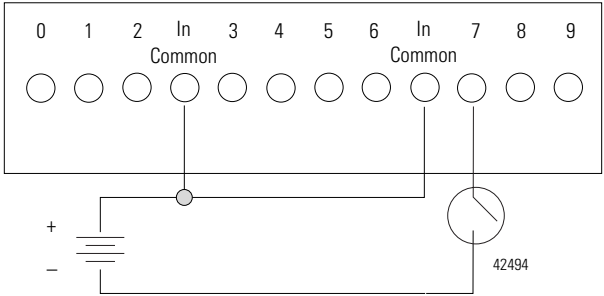

**Communicate with the Card**

This card exchanges I/O with the master on the DeviceNet network through a cyclic, polled, or change-of-state connection.

The card consumes and produces I/O data as follows:

<b>I/O Connection Type</b>	<b>Consumes</b>	<b>Produces</b>
Cyclic	2 Bytes	7 Bytes
Polled	2 Bytes	7 Bytes
Change-of-state	2 Bytes	7 Bytes

Cyclic — the card produces and consumes its I/O cyclically at the rate configured by the master on the DeviceNet network.

Polled — the master initiates communication by sending its polled I/O message to the card. The card consumes the message, updates any outputs, and produces a response containing the input data.

Change-of-state — a production occurs when an input changes. A heartbeat production occurs if no input condition change occurs within the expected packet rate. This heartbeat production tells the master that the card is ready to communicate. Consumption occurs when data changes and the master produces new output data to the card.

Refer to the following table for the word and bit definitions:

Byte	Bit 7	Bit 6	Bit 5	Bit 4	Bit 3	Bit 2	Bit 1	Bit 0
<b>Prod 0</b>	Input 7	Input 6	Input 5	Input 4	Input 3	Input 2	Input 1	Input 0
<b>Prod 1</b>	RSVD	Logic Ena	RSVD				Input 9	Input 8
<b>Prod 2</b>	Output 7	Output 6	Output 5	Output 4	Output 3	Output 2	Output 1	Output 0
<b>Prod 3</b>	RSVD						Output 9	Output 8
<b>Prod 4</b>	NetOut 7	NetOut 6	NetOut 5	NetOut 4	NetOut 3	NetOut 2	NetOut 1	NetOut 0
<b>Prod 5</b>	CCV 7	CCV 6	CCV 5	CCV 4	CCV 3	CCV 2	CCV 1	CCV 0
<b>Prod 6</b>	CCV 15	CCV 14	CCV 13	CCV 12	CCV 11	CCV 10	CCV 9	CCV 8
<b>Cons 0</b>	Output 7	Output 6	Output 5	Output 4	Output 3	Output 2	Output 1	Output 0
<b>Cons 1</b>	RSVD						Output 9	Output 8

RSVD = Reserved, Logic Ena = DeviceLogix enabled, NetOut = Network Output, CCV = Configuration Consistency Value,

## Configure the Parameters

The Zone Control cards have 42 parameters that are configurable through a DeviceNet configuration tool such as RSNetWorx for DeviceNet software. The DeviceNet configuration tools require an Electronic Data Sheet (EDS) for the Zone Control cards to configure the card's parameters. Find the EDS file can be found at <http://www.odva.org>.

Use the descriptions in the following table to help you configure the non-DeviceLogix parameters.

<b>Parameter</b>	<b>Description</b>
Baud Rate	Controls the card's communication rate.
AutoBaud	Enables the card to match the network's communication rate. When enabled, Baud Rate parameter is ignored.
Input Off-to-On Filter Time	Controls the amount of time the input must be in the on state before the card reports the input as on.
Input On-to-Off Filter Time	Controls the amount of time the input must be in the off state before the card reports the input as off.
Output Idle State	Controls the state of each output when the DeviceNet master is in an idle state.
Output Fault State	Controls the state of each output when the card loses communication with the DeviceNet master.
Output Idle Value	Controls the value that outputs will have when the output idle state is set to use idle value.
Output Fault Value	Controls the value that outputs will have when the output fault state is set to use fault value.

These DeviceLogix capable cards have additional parameters that are described in the DeviceLogix User Manual, publication number ACIG-UM001, and in the Embedded I/O for DeviceNet Technical Data, publication number 1799-TD001.

## Troubleshoot the Zone Cards

This card has the following indicators, shown in the picture below:

- Card status indicator
- Network status indicator
- DeviceLogix status
- Auxiliary power indicator
- I/O status indicators

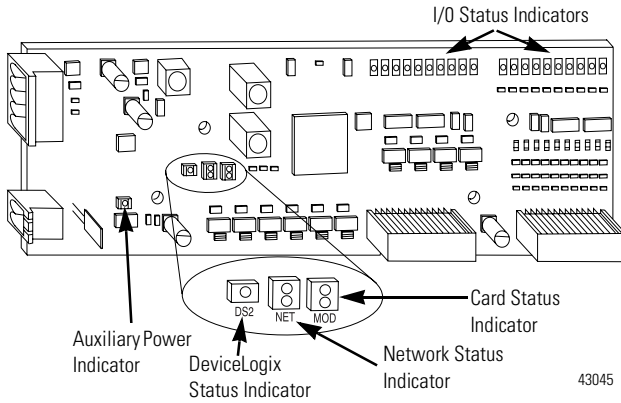

*Card Status Indicator (Labeled MOD)*

<b>Indication</b>	<b>Status</b>
None	No power
Green Blinking Solid	Needs commissioning Device operational
Red Blinking Solid	Minor fault Critical fault

*Network Status Indicator (Labeled NET)*

<b>Indication</b>	<b>Status</b>
None	Not on-line
Green Blinking Solid	On-line/no connections On-line/connected
Red Blinking Solid	Connection timed out Failed communication: a duplicate node address exists or card is at the wrong communication rate

*DeviceLogix Status Indicator (Labeled DS2)*

<b>Indication</b>	<b>Status</b>
None	Logic disabled
Green Solid Blinking	Logic enabled Local forces applied and local logic enabled

*Auxiliary Power Indicator (Labeled AUX PWR)*

<b>Indication</b>	<b>Status</b>
None	No auxiliary power
Green	Auxiliary power present

*I/O Status Indicators (Labeled Inputs and Outputs)*

<b>Indication</b>	<b>Status</b>
None	Input or output point off
Yellow	Input or output point on

## **Technical Support**

For additional troubleshooting information on the 1799 Zone Control I/O Cards, access Rockwell Automation's technical support services at 440.646.3223 or at <http://www.ab.com>.

## Specifications

### 10 Input/10 Output Card-Cat. Nos. 1799-ZCIOB, -D10U10BZC, -ZCIOV, & -D10U10VZC

Input Specification	Max	Min
Inputs per Block	10 sinking or sourcing, Type 1 + compatible	
Off-state: Voltage Current	5V dc 1.5 mA	- -
On-state: Voltage Current	30V dc 6 mA	10V dc 2 mA
Output Specification	Maximum	Minimum
Outputs per Block	10 sinking or sourcing, 0.5A, short circuit protected, pilot duty	
Output Auxiliary Voltage	30V	10V
On-state Voltage Drop	250 mV	-
On-state Current	0.5 A	-
Off-state Leakage	20 $\mu$ A	-
Card Current (All Outputs On)	4.0 A	-
Surge Current - for 10 ms, Repeatable Every 2 s (Individual Outputs)	1.0 A	-

### General Specifications

LED Indicators	Card Status - red/green, Network Status - red/green, Auxiliary Power - green, DeviceLogix Status - green, Input Point LED - yellow, Output Point LED -yellow
Dimensions - Millimeters (Inches)	26H x 51W x 163D (1.0H x 2.0W x 6.4D)
Operating Temperature	IEC 60068-2-1 (Test Ad, Operating Cold), IEC 60068-2-2 (Test Bd, Operating Dry Heat), IEC 60068-2-14 (Test Nb, Operating Thermal Shock): -10...60 $^{\circ}$ C (14...140 $^{\circ}$ F)

**10 Input/10 Output Card-Cat. Nos. 1799-ZCIOB, 1799-D10U10BZC, 1799-ZCIOV, & 1799-D10U10VZC**

**General Specifications (continued)**

Storage Temperature	IEC 60068-2-1 (Test Ab, Un-packaged Non-operating Cold), IEC 60068-2-2 (Test Bb, Un-packaged Non-operating Dry Heat), IEC 60068-2-14 (Test Na, Un-packaged Non-operating Thermal Shock): -40...85 °C (-40...185 °F)
Relative Humidity	IEC 60068-2-30 (Test Db, Un-packaged Non-operating Damp Heat): 5 to 95% non-condensing
Vibration	IEC60068-2-6 (Test Fc, Operating): 5 g @ 10...500 Hz
Shock	IEC60068-2-27 (Test Ea, Unpackaged Shock): Operating 30 g Non-operating 50 g
Emissions	CISPR 11: Group 1, Class A
ESD Immunity	IEC 61000-4-2: 6 kV indirect contact discharges
Radiated RF Immunity	IEC 61000-4-3: 10 V/m with 1k Hz sine-wave 80%AM from 30...1000 MHz 10 V/m with 200 Hz 50% Pulse 100%AM at 900 Mhz
EFT/B Immunity	IEC 61000-4-4: ±2 kV at 5 kHz on power ports ±4 kV at 2.5 kHz on signal ports ±2 kV at 5 kHz on communications ports
Surge Transient Immunity	IEC 61000-4-5: ±2 kV line-earth(CM) on power ports ±2 kV line-line(DM) and ±4 kV line-earth(CM) on signal ports ±2 kV line-line(CM) on communications ports
Conducted RF Immunity	IEC 61000-4-6: 10 Vrms with 1 kHz sine-wave 80%AM from 150 kHz...80 MHz
Enclosure Type Rating	None (open-style)

**10 Input/10 Output Card-Cat. Nos. 1799-ZCIOB, 1799-D10U10BZC, 1799-ZCIOV, & 1799-D10U10VZC**
**General Specifications (continued)**

DeviceNet Power: Voltage Current	25V dc max 125 mA max	11V dc min -
DeviceNet Power Circuit Type	Class 2	
Auxiliary Power: Voltage Current	30V dc max 4.0 A min (all outputs on)	10V dc min 100 mA min (All Outputs Off)
Auxiliary Supply Power Rating	Isolated outputs limited to 200VA in each ungrounded output line	
Isolation Voltage (Continuous-voltage Withstand Rating)	Tested to withstand 1000V dc for 60 s	
Conductors Wire Size	DeviceNet power: 0.25...2.5 mm <sup>2</sup> (22...14 AWG) solid or stranded copper wire rated at 75 °C or greater. Auxiliary power: 0.80...2.5 mm <sup>2</sup> (18...14 AWG) solid or stranded copper wire rated at 75 °C or greater. DeviceNet: 0.25...2.5 mm <sup>2</sup> (22...14 AWG) solid or stranded copper wire rated at 75 °C or greater. (See publication DNET-UM072) I/O: 0.13...0.5 mm <sup>2</sup> (26...20 AWG) solid or stranded copper wire rated at 75 °C or greater.	
Wiring Category <sup>(1)</sup>	1 - on signal ports 1 - on power ports 2 - on communications ports	

**10 Input/10 Output Card-Cat. Nos. 1799-ZCIOB, 1799-D10U10BZC, 1799-ZCIOV, & 1799-D10U10VZC**

**General Specifications (continued)**

Certifications <sup>(2)</sup> (When product is marked)	c-UR-us	UL Recognized Component Industrial Control Equipment, certified for US and Canada
	CE	European Union 89/336/EEC EMC Directive, compliant with: EN 50082-2; Industrial Immunity EN 61326; Meas./Control/Lab., Industrial Requirements EN 61000-6-2; Industrial Immunity EN 61000-6.4; Industrial Emissions EN 61131-2; Programmable Controllers (Clause 8, Zone A & B)
	C-Tick	Australian Radiocommunications Act, compliant with: AS/NZS CISPR 11; Industrial Emissions
	ODVA	ODVA conformance tested to DeviceNet specifications

Note: In order to comply with CE Low Voltage Directives (LVD), you must use either a NEC Class 2, a Safety Extra Low Voltage (SELV) or a Protected Extra Low Voltage (PELV) power supply to power this adapter. A SELV supply cannot exceed 30V rms, 42.4V peak or 60V dc under normal conditions and under single fault conditions. A PELV supply has the same rating and is connected to protected earth.

<sup>(1)</sup> Use this Conductor Category information for planning conductor routing. Refer to Publication 1770-4.1, "Industrial Automation Wiring and Grounding Guidelines".

<sup>(2)</sup> See the Product Certification link at [www.ab.com](http://www.ab.com) for Declarations of Conformity, Certificates, and other certification details.

RSNetWorx for DeviceNet and DeviceLogix are trademarks of Rockwell Automation, Inc.

Trademarks not belonging to Rockwell Automation are property of their respective companies.

**Notes:**

# Rockwell Automation Support

Rockwell Automation provides technical information on the web to assist you in using its products. At <http://support.rockwellautomation.com>, you can find technical manuals, a knowledge base of FAQs, technical and application notes, sample code and links to software service packs, and a MySupport feature that you can customize to make the best use of these tools.

For an additional level of technical phone support for installation, configuration and troubleshooting, we offer TechConnect Support programs. For more information, contact your local distributor or Rockwell Automation representative, or visit <http://support.rockwellautomation.com>.

## Installation Assistance

If you experience a problem with a hardware module within the first 24 hours of installation, please review the information that's contained in this manual. You can also contact a special Customer Support number for initial help in getting your module up and running:

United States	1.440.646.3223 Monday – Friday, 8am – 5pm EST
Outside United States	Please contact your local Rockwell Automation representative for any technical support issues.

## New Product Satisfaction Return

Rockwell tests all of its products to ensure that they are fully operational when shipped from the manufacturing facility. However, if your product is not functioning and needs to be returned:

United States	Contact your distributor. You must provide a Customer Support case number (see phone number above to obtain one) to your distributor in order to complete the return process.
Outside United States	Please contact your local Rockwell Automation representative for return procedure.

[www.rockwellautomation.com](http://www.rockwellautomation.com)

### Corporate Headquarters

Rockwell Automation, 777 East Wisconsin Avenue, Suite 1400, Milwaukee, WI, 53202-5302 USA, Tel: (1) 414.212.5200, Fax: (1) 414.212.5201

### Headquarters for Allen-Bradley Products, Rockwell Software Products and Global Manufacturing Solutions

Americas: Rockwell Automation, 1201 South Second Street, Milwaukee, WI 53204-2496 USA, Tel: (1) 414.382.2000, Fax: (1) 414.382.4444  
Europe/Middle East/Africa: Rockwell Automation SA/NV, Vorstlaan/Boulevard du Souverain 36, 1170 Brussels, Belgium, Tel: (32) 2 663 0600, Fax: (32) 2 663 0640  
Asia Pacific: Rockwell Automation, Level 14, Core F, Cyberport 3, 100 Cyberport Road, Hong Kong, Tel: (852) 2887 4788, Fax: (852) 2508 1846

### Headquarters for Dodge and Reliance Electric Products

Americas: Rockwell Automation, 6040 Ponders Court, Greenville, SC 29615-4617 USA, Tel: (1) 864.297.4800, Fax: (1) 864.281.2433  
Europe/Middle East/Africa: Rockwell Automation, Herman-Heinrich-Gossen-Strasse 3, 50858 Köln, Germany, Tel: 49 (0) 2234 379410, Fax: 49 (0) 2234 3794164  
Asia Pacific: Rockwell Automation, 55 Newton Road, #11-01/02 Revenue House, Singapore 307987, Tel: (65) 6356 9077, Fax: (65) 6356 9011

Publication 1799-IN007D-EN-P - October 2005

PN 957955-52

Supersedes Publication 1799-IN007C-EN-P - November 2004

Copyright © 2005 Rockwell Automation, Inc. All rights reserved. Printed in the U.S.A.