



Installation Instructions

CompactBlock Distributed I/O on Remote I/O Series D

(Cat. No. 1791R-16B0, -0B16P, -8B8P, -4B4P, -8V8P)

1791R CompactBlock™ I/O modules are stand-alone 24V dc Block I/O products that communicate via a Remote I/O link. Each Remote I/O node consists of either one base module or one base module and one expansion module. Any expansion module can be coupled with any base module. CompactBlock 1791R consists of only base modules. The expansion modules are part of the CompactBlock 1791D family of products.

CompactBlock Remote I/O modules must be installed in a secondary enclosure. Base modules are equipped with 8 to 16 points.

CompactBlock Remote I/O provides both sinking and sourcing inputs and outputs. Sinking inputs are 24V dc IEC Type 3 compatible. Self-protected 24V dc outputs can provide up to 0.5 amp each.

Important User Information

Because of the variety of uses for the products described in this publication, those responsible for the application and use of these products must satisfy themselves that all necessary steps have been taken to assure that each application and use meets all performance and safety requirements, including any applicable laws, regulations, codes and standards. In no event will Allen-Bradley be responsible or liable for indirect or consequential damage resulting from the use or application of these products.

2 CompactBlock Distributed I/O on Remote I/O Series D

Any illustrations, charts, sample programs, and layout examples shown in this publication are intended solely for purposes of example. Since there are many variables and requirements associated with any particular installation, Allen-Bradley does not assume responsibility or liability (to include intellectual property liability) for actual use based upon the examples shown in this publication.

Allen-Bradley publication SGI-1.1, *Safety Guidelines for the Application, Installation and Maintenance of Solid-State Control* (available from your local Allen-Bradley office), describes some important differences between solid-state equipment and electromechanical devices that should be taken into consideration when applying products such as those described in this publication.

Reproduction of the contents of this copyrighted publication, in whole or part, without written permission of Rockwell Automation, is prohibited.

Throughout this publication, notes may be used to make you aware of safety considerations. The following annotations and their accompanying statements help you to identify a potential hazard, avoid a potential hazard, and recognize the consequences of a potential hazard:

WARNING

Identifies information about practices or circumstances that can cause an explosion in a hazardous environment, which may lead to personal injury or death, property damage, or economic loss.

IMPORTANT

Identifies information that is critical for successful application and understanding of the product.

ATTENTION

Identifies information about practices or circumstances that can lead to personal injury or death, property damage, or economic loss.

Environment and Enclosure

This equipment is intended for use in a Pollution Degree 2 industrial environment, in overvoltage Category II applications (as defined in IEC publication 60664-1), at altitudes up to 2000 meters without derating.

This equipment is considered Group 1, Class A industrial equipment according to IEC/CISPR Publication 11. Without appropriate precautions, there may be potential difficulties ensuring electromagnetic compatibility in other environments due to conducted as well as radiated disturbance.

ATTENTION



This equipment is supplied as "enclosed" equipment. It should not require additional system enclosure when used in locations consistent with the enclosure type ratings stated in the Specifications section of this publication. Subsequent sections of this publication may contain additional information regarding specific enclosure type ratings, beyond what this product provides, that are required to comply with certain product safety certifications.

NOTE: See NEMA Standards publication 250 and IEC publication 60529, as applicable, for explanations of the degrees of protection provided by different types of enclosure. Also, see the appropriate sections in this publication, as well as the Allen-Bradley publication 1770-4.1 ("Industrial Automation Wiring and Grounding Guidelines"), for additional installation requirements pertaining to this equipment.

Rockwell Automation Support

Rockwell Automation provides technical information on the web to assist you in using our products. At <http://support.rockwellautomation.com>, you can find technical manuals, a knowledge base of FAQs, technical and application notes, sample code and links to software service packs, and a MySupport feature that you can customize to make the best use of these tools.

For an additional level of technical phone support for installation, configuration and troubleshooting, we offer TechConnect Support programs. For more information, contact your local distributor or Rockwell Automation representative, or visit <http://support.rockwellautomation.com>.

Installation Assistance

If you experience a problem with a hardware module within the first 24 hours of installation, please review the information that's contained in this manual. You can also contact a special Customer Support number for initial help in getting your module up and running:

United States	1.440.646.3223 Monday – Friday, 8am – 5pm EST
Outside United States	Please contact your local Rockwell Automation representative for any technical support issues.

New Product Satisfaction Return

Rockwell tests all of our products to ensure that they are fully operational when shipped from the manufacturing facility. However, if your product is not functioning and needs to be returned:

United States	Contact your distributor. You must provide a Customer Support case number (see phone number above to obtain one) to your distributor in order to complete the return process.
Outside United States	Please contact your local Rockwell Automation representative for return procedure.

Installing CompactBlock I/O

Follow these steps, to install the 1791R I/O module:

1. Set the Node Address on the Base Module.
2. Mount the Block(s).
3. Connect the Input/Output Wires to the Block.
4. Connect the RIO Cable.
5. Select termination for the module.
6. Connect power to the module.
7. Remove the terminal block.
8. Insert the terminal block.
9. Communicate with the 1791R Module.

These steps are explained in detail in the following procedures.

Preventing Electrostatic Discharge

This equipment is sensitive to electrostatic discharge, which can cause internal damage and affect normal operation. Follow these guidelines when you handle this equipment:

ATTENTIO

- Touch a grounded object to discharge potential static.
 - Wear an approved grounding wriststrap.
 - Do not touch connectors or pins on component boards.
 - Do not touch circuit components inside the equipment.
 - If available, use a static-safe workstation.
 - When not in use, store the equipment in appropriate static-safe packaging.
-

Set the Node Address on the Base Module

The node address for network connection is set using two 8-bit DIP switches. To set the node address, lift the door containing the status LEDs on the top left side of the module. The switches are read at module power up only. The rack address setting and the starting quarter setting are described below.

IMPORTANT

It is important to monitor the rack fault bit. When installing a system for the first time, it is possible to mistakenly put devices with duplicate rack addresses on the same network. Blocks with duplicate addresses may in certain instances cause outputs to toggle on/off until the duplicate address error is corrected.

View when looking into module

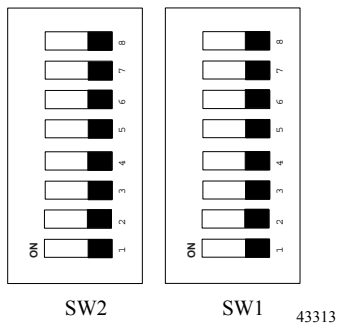

DIP Switch Settings

The 1791R DIP switches are described in the table below.

DIP Switch	Description	Starting Quarter		
SW1	Starting Quarter	SW1-2	SW1-1	Module Group
	Starting Quarter	0	0	0 (1st)
		0	1	2 (2nd)
		1	0	4 (3rd)
		1	1	6 (4th)

DIP Switch	No.	Description	
SW1	3	Rack Address	See table below.
	4	Rack Address	
	5	Rack Address	
	6	Rack Address	
	7	Rack Address	
	8	Rack Address	

Rack Address (6 bit): Position in scanner data mapping.

Starting Quarter: Position in Rack Address with 1/4 rack size data.

8 CompactBlock Distributed I/O on Remote I/O Series D

Rack addresses are listed in the table below.

1747-SN Rack Number	1771-SN Rack Number	PLC-2 Rack Number	PLC-5 Rack Number	PLC5/250 Rack Number	PLC-3 Rack Number	SW1 Switch Position					
						8	7	6	5	4	3
Rack 0	Rack 1	Rack 1	Not Valid	Rack 0	Rack 0	0	0	0	0	0	0
Rack 1	Rack 2	Rack 2	Rack 1	Rack 1	Rack 1	0	0	0	0	0	1
Rack 2	Rack 3	Rack 3	Rack 2	Rack 2	Rack 2	0	0	0	0	1	0
Rack 3	Rack 4	Rack 4	Rack 3	Rack 3	Rack 3	0	0	0	0	1	1
	Rack 5	Rack 5	Rack 4	Rack 4	Rack 4	0	0	0	1	0	0
	Rack 6	Rack 6	Rack 5	Rack 5	Rack 5	0	0	0	1	0	1
	Rack 7	Rack 7	Rack 6	Rack 6	Rack 6	0	0	0	1	1	0
			Rack 7	Rack 7	Rack 7	0	0	0	1	1	1
			Rack 10	Rack 10	Rack 10	0	0	1	0	0	0
			Rack 11	Rack 11	Rack 11	0	0	1	0	0	1
			Rack 12	Rack 12	Rack 12	0	0	1	0	1	0
			Rack 13	Rack 13	Rack 13	0	0	1	0	1	1
			Rack 14	Rack 14	Rack 14	0	0	1	1	0	0
			Rack 15	Rack 15	Rack 15	0	0	1	1	0	1
			Rack 16	Rack 16	Rack 16	0	0	1	1	1	0
			Rack 17	Rack 17	Rack 17	0	0	1	1	1	1
			Rack 20	Rack 20	Rack 20	0	1	0	0	0	0
			Rack 21	Rack 21	Rack 21	0	1	0	0	0	1
			Rack 22	Rack 22	Rack 22	0	1	0	0	1	0
			Rack 23	Rack 23	Rack 23	0	1	0	0	1	1
		Rack 24	Rack 24	Rack 24	0	1	0	1	0	0	
		Rack 25	Rack 25	Rack 25	0	1	0	1	0	1	
		Rack 26	Rack 26	Rack 26	0	1	0	1	1	0	
		Rack 27	Rack 27	Rack 27	0	1	0	1	1	1	

1747-SN Rack Number	1771-SN Rack Number	PLC-2 Rack Number	PLC-5 Rack Number	PLC5/250 Rack Number	PLC-3 Rack Number	SW1 Switch Position					
						8	7	6	5	4	3
				Rack 30	Rack 30	0	1	1	0	0	0
				Rack 31	Rack 31	0	1	1	0	0	1
				Rack 32	Rack 32	0	1	1	0	1	0
				Rack 33	Rack 33	0	1	1	0	1	1
				Rack 34	Rack 34	0	1	1	1	0	0
				Rack 35	Rack 35	0	1	1	1	0	1
				Rack 36	Rack 36	0	1	1	1	1	0
				Rack 37	Rack 37	0	1	1	1	1	1
					Rack 40	1	0	0	0	0	0
					Rack 41	1	0	0	0	0	1
					Rack 42	1	0	0	0	1	0
					Rack 43	1	0	0	0	1	1
					Rack 44	1	0	0	1	0	0
					Rack 45	1	0	0	1	0	1
					Rack 46	1	0	0	1	1	0
					Rack 47	1	0	0	1	1	1
					Rack 50	1	0	1	0	0	0
					Rack 51	1	0	1	0	0	1
					Rack 52	1	0	1	0	1	0
					Rack 53	1	0	1	0	1	1
					Rack 54	1	0	1	1	0	0
					Rack 55	1	0	1	1	0	1
					Rack 56	1	0	1	1	1	0
					Rack 57	1	0	1	1	1	1
					Rack 60	1	1	0	0	0	0
					Rack 61	1	1	0	0	0	1

10 CompactBlock Distributed I/O on Remote I/O Series D

1747-SN Rack Number	1771-SN Rack Number	PLC-2 Rack Number	PLC-5 Rack Number	PLC5/250 Rack Number	PLC-3 Rack Number	SW1 Switch Position					
						8	7	6	5	4	3
					Rack 62	1	1	0	0	1	0
					Rack 63	1	1	0	0	1	1
					Rack 64	1	1	0	1	0	0
					Rack 65	1	1	0	1	0	1
					Rack 66	1	1	0	1	1	0
					Rack 67	1	1	0	1	1	1
					Rack 70	1	1	1	0	0	0
					Rack 71	1	1	1	0	0	1
					Rack 72	1	1	1	0	1	0
					Rack 73	1	1	1	0	1	1
					Rack 74	1	1	1	1	0	0
					Rack 75	1	1	1	1	0	1
					Rack 76	1	1	1	1	1	0
					Not Valid	1	1	1	1	1	1

Rack address 77 is an illegal configuration.

PLC-5/11 processors can scan rack 03.

PLC5/15 and PLC-5/20 processors can scan racks 01-03.

PLC5/25 and PLC-5/30 processors can scan racks 01-07.

PLC5/40 and PLC-5/40L processors can scan racks 01-17.

PLC5/60 and PLC-5/60L processors can scan racks 01-27.

PLC5/250 processors can scan racks 00-37.

DIP Switch	No.	Description	ON	OFF
SW2	1	Comm Rate	00=57.6K 10=230.4K	01=115.2K 11=230.4K
	2	Comm Rate		
	3		N/A	
	4	Hold Last State	Hold Last State	Output Reset
	5	Processor Restart/Lockout	Lockout	Restart
	6	Last I/O	Last Rack	Not Last Rack
	7	Filter Speed Setting	00=2ms 01=8ms	10=4ms 11=16ms
	8	Filter Speed Setting		

Mount the Block(s)

The base and expansion modules mount to a panel or DIN rail which must be grounded before installing the module(s).

Base Module Mounting

Install the Compact**Block** base module on a panel or DIN rail.

WARNING



When used in a Class I, Division 2, hazardous location, this equipment must be mounted in a suitable enclosure with proper wiring method that complies with the governing electrical codes.

12 CompactBlock Distributed I/O on Remote I/O Series D

Panel Mounting

1. Place the module against the panel where you want to mount it.
2. Drill holes in the panel that are aligned with mounting holes on the module.
3. Place screws through each of the 2 mounting holes and tighten until the module is firmly in place.

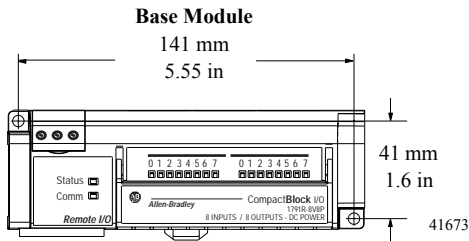

DIN Rail Mounting

1. Hook top of slot over the DIN Rail.
2. Pull down on the locking lever while pressing the block against the rail.

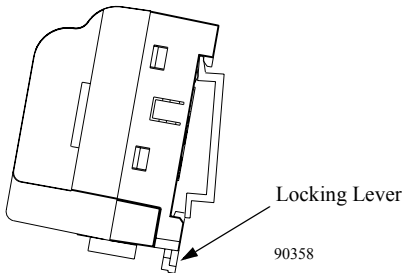

3. Push up on the locking lever to secure the block to the rail when block is flush against the rail.

Connecting an Expansion Module to a Base Module

ATTENTION



Expansion blocks should not be installed when power is applied to the base.

IMPORTANT

Carefully read the section on I/O images for 1791R base modules starting on page 22 to change produce and consume data sizes.

1. Remove the expansion covers from both the base and expansion modules.
2. Position the expansion block with the proper spacing. See the illustration below.

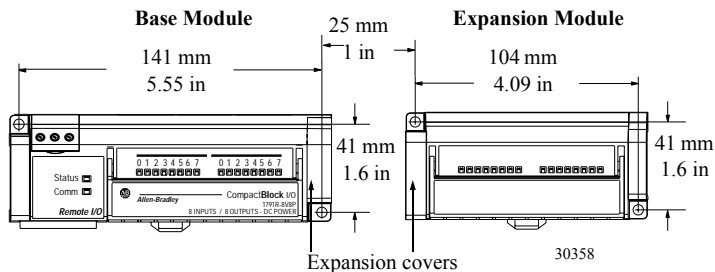

3. Mount expansion module using panel or DIN rail mounting, as described in the previous section.

14 CompactBlock Distributed I/O on Remote I/O Series D

4. Plug the expansion cable into both the base and expansion modules.
-

IMPORTANT

The expansion cable can only be connected to the modules such that the red stripe on the cable is on top as shown below.

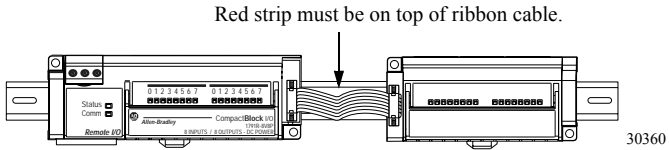

5. Replace the expansion covers on both modules.

Connect the Input/Output Wires to the Block

Two sets of VDC+ and GND power pins are located on each terminal (one for each bank of 8 points) except on the 1791R-4B4P module. The following figures show the wiring information for both sinking and sourcing wiring. Input and Output wiring use up to 14AWG (2mm²) stranded (Cu) with 3/64 inch insulation.

WARNING



Use supply wires suitable for 30°C above surrounding ambient.

Output Wiring Diagram for 1791R-0B16P and 1791D-0B16PX Modules

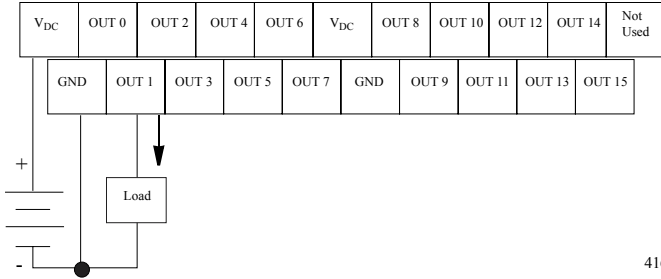

Input Wiring Diagram for 1791R-16B0 and 1791D-16B0X Modules

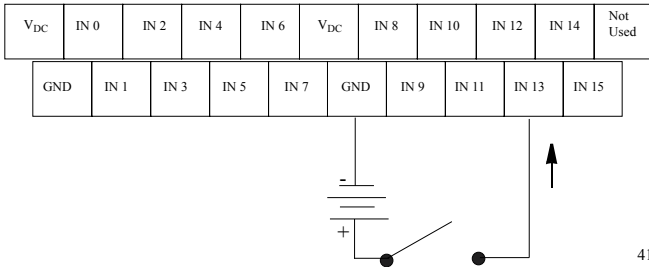

Wiring Diagram for the 1791R-8B8P Module

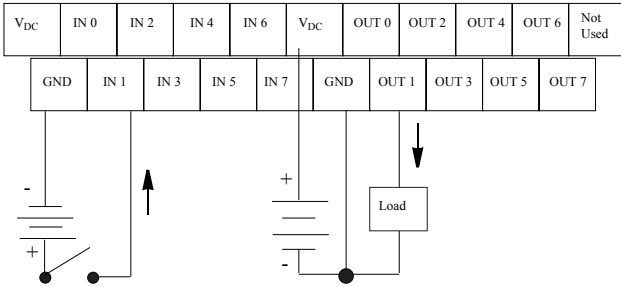

41672

Wiring Diagram for the 1791R-4B4P Module

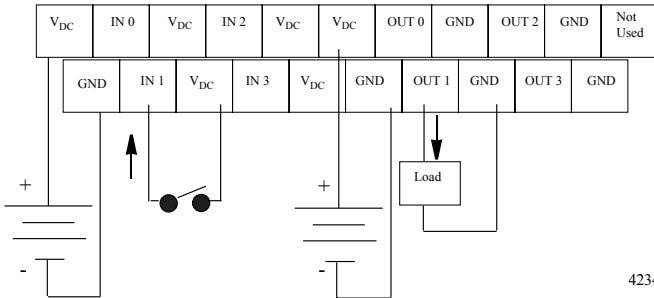

42344

Wiring Diagram for the 1791R-8V8P Module

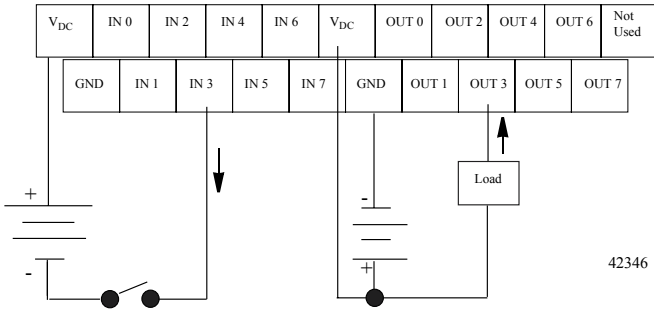

Output Wiring Diagram for 1791D-0V16PX Module

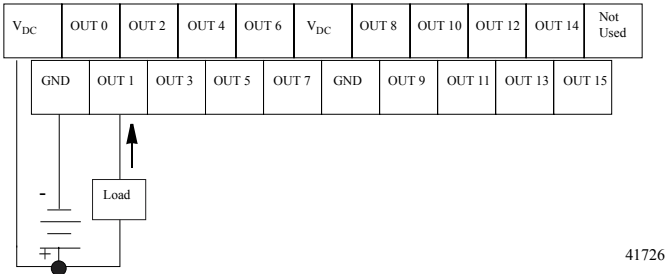

Input Wiring Diagram for 1791D-16V0X Module

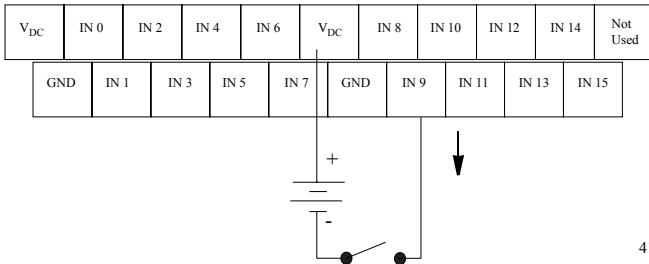

Connect the Remote I/O Terminal Connector

Refer to the following information when connecting the Remote I/O terminal connector to the 1791R block I/O.

WARNING



If you connect or disconnect the serial cable with power applied to this module or the serial device on the other end of the cable, an electrical arc can occur. This could cause an explosion in hazardous location installations. Be sure that power is removed or the area is nonhazardous before proceeding.

1. Connect the Remote I/O female 3-pin connector to the terminal connector as shown below.

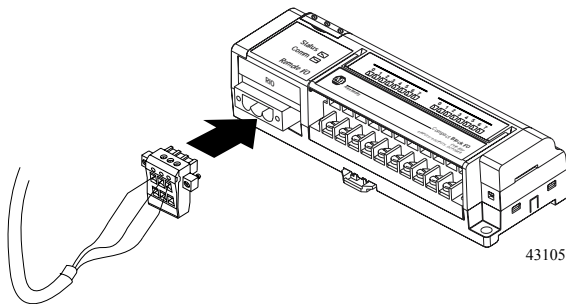

2. Connect the terminal connector to the Block. Use the side screws on the terminal connector to fasten it to the Block.

Pin Number:	Wire Color:	Description:
1	blue	Line 1
2	shield	Shield
3	clear	Line 2

Select Termination for the Module

The terminator resistor is provided in the module. Use the DIP switches to select termination for the module. See below.

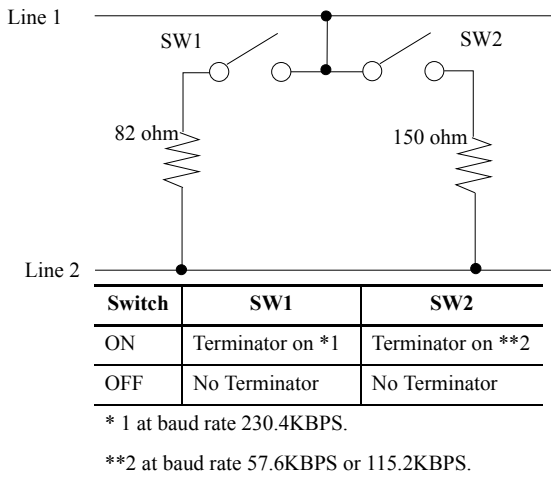

43107

Base Module to Expansion Interface

The base module is linked to the expansion module with an 8-bit parallel bus, control lines, Vcc and ground connections, a reset/initialization line, and an expansion presence line. The 8-bit bus is multiplexed so that 16 bits of data (1 for each I/O point) can be transmitted/received with two transfers. The reset/initialization line is used during initialization of the module. The presence line is used for the detection of an expansion module at power up and for a period of each data transfer. Module ID is read over this bus at power up.

1791R modules supply expansion power via expansion bus as follows:

Expansion power voltage	5Vdc
Expansion power current	100mA

Connect Power to the Module

To apply power to the 1791R module, refer to the illustration below.

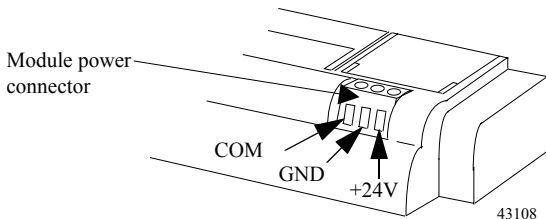

Pin Number	Name
1	Com (24V dc return)
2	Gnd (Field ground)
3	+24V dc

Remove the Terminal Block

WARNING



When you connect or disconnect the Removable Terminal Block (RTB) with field side power applied, an electrical arc can occur. This could cause an explosion in hazardous location installations.

Be sure that power is removed or the area is nonhazardous before proceeding.

Follow the directions below to remove the CompactBlock terminal block.

1. Unscrew the two retaining screws on the side of the terminal block.

2. Lift the terminal block out of the base.

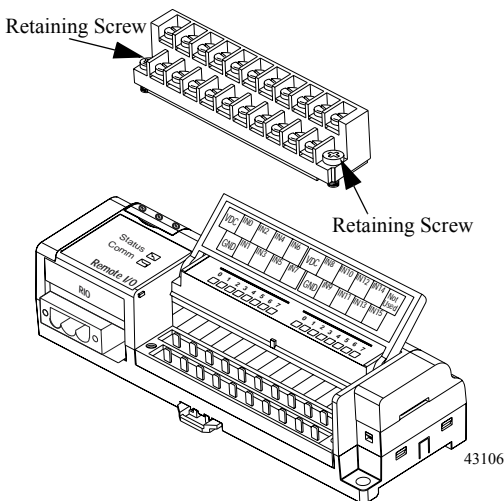

Insert the Terminal Block

Follow the directions below to insert the Compact**Block** terminal block.

1. Insert the terminal block by aligning it and pushing it back until it rests against the back of the module.
2. Tighten the screws on each side of the terminal block until the terminal block is firmly in place.

Communicate With the 1791R Module

Determine the Baud Rate for Your Remote I/O Connection

Use the DIP switches to set the baud rate before you power up the module.

Refer to the following table for baud rate specifications.

Baud Rate	Cable Length
57.6KBPS	3048m
115.2KBPS	1524m
230.4KBPS	762m

I/O Image Word/Bit Definitions

The smallest portion of a scanner's I/O image that can be allocated to a single Remote I/O device is two logical groups or 1/4 logical rack. A device's starting group must begin at even group numbers (0, 2, 4, or 6). See your scanner documentation for further details.

All combinations of 1791R base and expansion modules will fit in the space allocated by 1/4 logical rack, except for the 1791D-N4CV2X analog module, which fits in a 3/4 rack.

I/O images for 1791 Remote I/O base modules follow.

16B0																
	17	16	15	14	13	12	11	10	7	6	5	4	3	2	1	0
Input Image	In 15	In 14	In 13	In 12	In 11	In 10	In 9	In 8	In 7	In 6	In 5	In 4	In 3	In 2	In 1	In 0
Input Image	Reserved															
Output Image	Reserved															
Output Image	Reserved															

0B16P																
	17	16	15	14	13	12	11	10	7	6	5	4	3	2	1	0
Input Image	Reserved															
Input Image	Reserved															
Output Image	O 15	O 14	O 13	O 12	O 11	O 10	O 9	O 8	O 7	O 6	O 5	O 4	O 3	O 2	O 1	O 0
Output Image	Reserved															

8B8P/8V8P																
	17	16	15	14	13	12	11	10	7	6	5	4	3	2	1	0
Input Image	Reserved								In 7	In 6	In 5	In 4	In 3	In 2	In 1	In 0
Input Image	Reserved															
Output Image	Reserved								O 7	O 6	O 5	O 4	O 3	O 2	O 1	O 0
Output Image	Reserved															

4B4P																
	17	16	15	14	13	12	11	10	7	6	5	4	3	2	1	0
Input Image	Reserved											In 3	In 2	In 1	In 0	
Input Image	Reserved															
Output Image	Reserved											O 3	O 2	O 1	O 0	
Output Image	Reserved															

24 CompactBlock Distributed I/O on Remote I/O Series D

The following examples are for 1791 Remote I/O base modules with expansion modules.

0B16P with 0B16PX																
	17	16	15	14	13	12	11	10	7	6	5	4	3	2	1	0
Input Image	Reserved															
Input Image	Reserved															
Output Image	O 15	O 14	O 13	O 12	O 11	O 10	O 9	O 8	O 7	O 6	O 5	O 4	O 3	O 2	O 1	O 0
Output Image	EX O 15	EX O 14	EX O 13	EX O 12	EX O 11	EX O 10	EX O 9	EX O 8	EX O 7	EX O 6	EX O 5	EX O 4	EX O 3	EX O 2	EX O 1	EX O 0

16B0 with 16BOX																
	17	16	15	14	13	12	11	10	7	6	5	4	3	2	1	0
Input Image	In 15	In 14	In 13	In 12	In 11	In 10	In 9	In 8	In 7	In 6	In 5	In 4	In 3	In 2	In 1	In 0
Input Image	EX In 15	EX In 14	EX In 13	EX In 12	EX In 11	EX In 10	EX In 9	EX In 8	EX In 7	EX In 6	EX In 5	EX In 4	EX In 3	EX In 2	EX In 1	EX In 0
Output Image	Reserved															
Output Image	Reserved															

16B0 with 0B16X or 0B16P with 16BOX																
	17	16	15	14	13	12	11	10	7	6	5	4	3	2	1	0
Input Image	In 15	In 14	In 13	In 12	In 11	In 10	In 9	In 8	In 7	In 6	In 5	In 4	In 3	In 2	In 1	In 0
Input Image	Reserved															
Output Image	O 15	O 14	O 13	O 12	O 11	O 10	O 9	O 8	O 7	O 6	O 5	O 4	O 3	O 2	O 1	O 0
Output Image	Reserved															

8B8P with 16BOX or 8V8P with 16VOX																
	17	16	15	14	13	12	11	10	7	6	5	4	3	2	1	0
Input Image	EX In 7	EX In 6	EX In 5	EX In 4	EX In 3	EX In 2	EX In 1	EX In 0	In 7	In 6	In 5	In 4	In 3	In 2	In 1	In 0
Input Image	Reserved								EX In 15	EX In 14	EX In 13	EX In 12	EX In 11	EX In 10	EX In 9	EX In 8
Output Image	Reserved								O 7	O 6	O 5	O 4	O 3	O 2	O 1	O 0
Output Image	Reserved															

8B8P with 0B16PX or 8V8P with 0V16PX																
	17	16	15	14	13	12	11	10	7	6	5	4	3	2	1	0
Input Image	Reserved								In 7	In 6	In 5	In 4	In 3	In 2	In 1	In 0
Input Image	Reserved															
Output Image	EX O 7	EX O 6	EX O 5	EX O 4	EX O 3	EX O 2	EX O 1	EX O 0	O 7	O 6	O 5	O 4	O 3	O 2	O 1	O 0
Output Image	Reserved								EX O 15	EX O 14	EX O 13	EX O 12	EX O 11	EX O 10	EX O 9	EX O 8

4B4P with 16BOX																
	17	16	15	14	13	12	11	10	7	6	5	4	3	2	1	0
Input Image	EX In 11	EX In 10	EX In 9	EX In 8	EX In 7	EX In 6	EX In 5	EX In 4	EX In 3	EX In 2	EX In 1	EX In 0	In 3	In 2	In 1	In 0
Input Image	Reserved											EX In 15	EX In 14	EX In 13	EX In 12	
Output Image	Reserved											O 3	O 2	O 1	O 0	
Output Image	Reserved															

26 CompactBlock Distributed I/O on Remote I/O Series D

4B4P with 0B16PX																
	17	16	15	14	13	12	11	10	7	6	5	4	3	2	1	0
Input Image	Reserved												In 3	In 2	In 1	In 0
Input Image	Reserved															
Output Image	EX O 11	EX O 10	EX O 9	EX O 8	EX O 7	EX O 6	EX O 5	EX O 4	EX O 3	EX O 2	EX O 1	EX O 0	O 3	O 2	O 1	O 0
Output Image	Reserved												EX O 15	EX O 14	EX O 13	EX O 12

Following are data tables for internal usage between base and expansion modules.

Maximum Input Data Format (Base Modules -16B0 or -16V0)																	
	Bit Position																
Word	15	14	13	12	11	10	9	8	7	6	5	4	3	2	1	0	
0	In15	In14	In13	In12	In11	In10	In9	In8	In7	In6	In5	In4	In3	In2	In1	In0	Base
1	Reserved				Analog Input Data Channel 0												
2	Reserved				Analog Input Data Channel 1												
3	Reserved				Analog Input Data Channel 2												
4	Reserved				Analog Input Data Channel 3												
5	URo1	URo0	ORo1	ORo0	OW3	OW2	OW1	OW0	ORi3	ORi2	ORi1	ORi0	Reserved	RF	UF		

UF Module Unrecoverable Fault Set "0": No Error Set "1": Error
 RF Module Recoverable Fault Set "0": No Error Set "1": Error
 ORi x Over Range Input Channel Set "0": No Over Range Set "1": Over Range
 OW x Input Open Wire (@ 4-20mA Range) Set "0": No Open Wire Set "1": Open Wire
 ORo x Output Data Over Range Set "0": No Over Range Set "1": Over Range
 URo x Output Data Under Range (@ 4-20mA Range) Set "0": No Under Range Set "1": Under Range

Maximum Output Data Format (Base Modules -0B16P or -0V16P)

Word	Bit Position																Base
	15	14	13	12	11	10	9	8	7	6	5	4	3	2	1	0	
0	O15	O14	O13	O12	O11	O10	O9	O8	O7	O6	O5	O4	O3	O2	O1	O0	
1	Reserved				Analog Output Data Channel 0												
2	Reserved				Analog Output Data Channel 1												
3	OE	HLS	R	IF	IR3	IR2	IR1	IR0	IM3	IM2	IM1	IM0	OR1	OR0	OM1	OM0	
OM x	Output Mode Selection				Set "0": Voltage Mode				Set "1": Current Mode								
OR x	Output Range Selection on Current Mode				Set "0": 4-20mA				Set "1": 0-20mA								
IM x	Input Channel Mode Select				Set "0": Voltage Mode				Set "1": Current Mode								
IR x	Input Range Select on Current Mode				Set "0": 4-20mA				Set "1": 0-20mA								
IF	Input Filter Selection				Set "0": 50Hz				Set "1": 60Hz								
R	Reserved;																
HLS	HLS/OFF				Set "0": Output Reset				Set "1": Hold Last State								
OE	Output Enable				Set "0": Output Disabled (Output is 0mA at 0-20mA mode and 4-20mA mode and 0V at 0-10V mode when this bit is 0)				Set "1": Output Enabled								

Following are data tables on RSLogix500.

Maximum Input Data Format (Base Modules -16B0)

Word	Bit Position																Base
	15	14	13	12	11	10	9	8	7	6	5	4	3	2	1	0	
0	In15	In14	In13	In12	In11	In10	In9	In8	In7	In6	In5	In4	In3	In2	In1	In0	
1	Reserved				Analog Input Data Channel 0												
2	Reserved				Analog Input Data Channel 1												
3	Reserved				Analog Input Data Channel 2												
4	Reserved				Analog Input Data Channel 3												
5	URo1	URo0	ORo1	ORo0	OW3	OW2	OW1	OW0	ORi3	ORi2	ORi1	ORi0	Reserved	RF	UF		
UF	Module Unrecoverable Fault				Set "0": No Error				Set "1": Error								
RF	Module Recoverable Fault				Set "0": No Error				Set "1": Error								
ORi x	Over Range Input Channel				Set "0": No Over Range				Set "1": Over Range								
OW x	Input Open Wire (@ 4-20mA Range)				Set "0": No Open Wire				Set "1": Open Wire								
ORo x	Output Data Over Range				Set "0": No Over Range				Set "1": Over Range								
URo x	Output Data Under Range (@4-20MA Range)				Set "0": No Under Range				Set "1": Under Range								

28 CompactBlock Distributed I/O on Remote I/O Series D

Maximum Output Data Format (Base Modules -16B0)

Word	Bit Position															
	15	14	13	12	11	10	9	8	7	6	5	4	3	2	1	0
0	Reserved				Analog Output Data Channel 0											
1	Reserved				Analog Output Data Channel 1											
2	OE	HLS	R	IF	IR3	IR2	IR1	IR0	IM3	IM2	IM1	IM0	OR1	OR0	OM1	OM0
3	Reserved															
4	Reserved															
5	Reserved															
OM x	Output Mode Selection				Set "0": Voltage Mode				Set "1": Current Mode							
OR x	Output Range Selection on Current Mode				Set "0": 4-20mA				Set "1": 0-20mA							
IM x	Input Channel Mode Select				Set "0": Voltage Mode				Set "1": Current Mode							
IR x	Input Range Select on Current Mode				Set "0": 4-20mA				Set "1": 0-20mA							
IF	Input Filter Selection				Set "0": 50Hz				Set "1": 60Hz							
R	Reserved;															
HLS	HLS/OFF				Set "0": Output Reset				Set "1": Hold Last State							
OE	Output Enable				Set "0": Output Disabled				Set "1": Output Enabled				(Output is 0mA at 0-20mA mode and 4-20mA mode and 0V at 0-10V mode when this bit is 0)			

Maximum Input Data Format (Base Modules -0B16)

Word	Bit Position															
	15	14	13	12	11	10	9	8	7	6	5	4	3	2	1	0
0	Reserved				Analog Input Data Channel 0											
1	Reserved				Analog Input Data Channel 1											
2	Reserved				Analog Input Data Channel 2											
3	Reserved				Analog Input Data Channel 3											
4	URo1	URo0	ORo1	ORo0	OW3	OW2	OW1	OW0	ORi3	ORi2	ORi1	ORi0	Reserved	RF	UF	
5	Reserved															
UF	Module Unrecoverable Fault				Set "0": No Error				Set "1": Error							
RF	Module Recoverable Fault				Set "0": No Error				Set "1": Error							
ORi x	Over Range Input Channel				Set "0": No Over Range				Set "1": Over Range							
OW x	Input Open Wire (@ 4-20mA Range)				Set "0": No Open Wire				Set "1": Open Wire							
ORo x	Output Data Over Range				Set "0": No Over Range				Set "1": Over Range							
URo x	Output Data Under Range (@4-20MA Range)				Set "0": No Under Range				Set "1": Under Range							

Maximum Output Data Format (Base Modules -16B0)

Word	Bit Position																Base
	15	14	13	12	11	10	9	8	7	6	5	4	3	2	1	0	
0	O15	O14	O13	O12	O11	O10	O9	O8	O7	O6	O5	O4	O3	O2	O1	O0	
1	Reserved				Analog Output Data Channel 0												
2	Reserved				Analog Output Data Channel 1												
3	OE	HLS	R	IF	IR3	IR2	IR1	IR0	IM3	IM2	IM1	IM0	OR1	OR0	OM1	OM0	
4	Reserved																
5	Reserved																

OM x	Output Mode Selection	Set "0": Voltage Mode	Set "1": Current Mode
OR x	Output Range Selection on Current Mode	Set "0": 4-20mA	Set "1": 0-20mA
IM x	Input Channel Mode Select	Set "0": Voltage Mode	Set "1": Current Mode
IR x	Input Range Select on Current Mode	Set "0": 4-20mA	Set "1": 0-20mA
IF	Input Filter Selection	Set "0": 50Hz	Set "1": 60Hz
R	Reserved		
HLS	HLS/OFF	Set "0": Output Reset	Set "1": Hold Last State
OE	Output Enable	Set "0": Output Disabled (Output is 0mA at 0-20mA mode and 4-20mA mode and 0V at 0-10V mode when this bit is 0)	Set "1": Output Enabled

Maximum Input Data Format (Base Modules -8B8P or -8V8P)

Word	Bit Position																Base
	15	14	13	12	11	10	9	8	7	6	5	4	3	2	1	0	
0	Reserved								In7	In6	In5	In4	In3	In2	In1	In0	
1	Reserved				Analog Input Data Channel 0												
2	Reserved				Analog Input Data Channel 1												
3	Reserved				Analog Input Data Channel 2												
4	Reserved				Analog Input Data Channel 3												
5	URo1	URo0	ORo1	ORo0	OW3	OW2	OW1	OW0	ORi3	ORi2	ORi1	ORi0	Reserved		RF	UF	

UF	Module Unrecoverable Fault	Set "0": No Error	Set "1": Error
RF	Module Recoverable Fault	Set "0": No Error	Set "1": Error
ORi x	Over Range Input Channel	Set "0": No Over Range	Set "1": Over Range
OW x	Input Open Wire (@ 4-20mA Range)	Set "0": No Open Wire	Set "1": Open Wire
ORo x	Output Data Over Range	Set "0": No Over Range	Set "1": Over Range
URo x	Output Data Under Range (@4-20MA Range)	Set "0": No Under Range	Set "1": Under Range

30 CompactBlock Distributed I/O on Remote I/O Series D

Maximum Output Data Format (Base Modules -8B8P or -8V8P)

Word	Bit Position																Base
	15	14	13	12	11	10	9	8	7	6	5	4	3	2	1	0	
0	Reserved								O7	O6	O5	O4	O3	O2	O1	O0	
1	Reserved				Analog Output Data Channel 0												
2	Reserved				Analog Output Data Channel 1												
3	OE	HLS	R	IF	IR3	IR2	IR1	IR0	IM3	IM2	IM1	IM0	OR1	OR0	OM1	OM0	
4	Reserved																
5	Reserved																

OM x	Output Mode Selection	Set "0": Voltage Mode	Set "1": Current Mode
OR x	Output Range Selection on Current Mode	Set "0": 4-20mA	Set "1": 0-20mA
IM x	Input Channel Mode Select	Set "0": Voltage Mode	Set "1": Current Mode
IR x	Input Range Select on Current Mode	Set "0": 4-20mA	Set "1": 0-20mA
IF	Input Filter Selection	Set "0": 50Hz	Set "1": 60Hz
R	Reserved,		
HLS	HLS/OFF	Set "0": Output Reset	Set "1": Hold Last State
OE	Output Enable	Set "0": Output Disabled	Set "1": Output Enabled (Output is 0mA at 0-20mA mode and 4-20mA mode and 0V at 0-10V mode when this bit is 0)

Maximum Input Data Format (Base Modules -4B4P)

Word	Bit Position																Base
	15	14	13	12	11	10	9	8	7	6	5	4	3	2	1	0	
0	Reserved												In3	In2	In1	In0	
1	Reserved				Analog Input Data Channel 0												
2	Reserved				Analog Input Data Channel 1												
3	Reserved				Analog Input Data Channel 2												
4	Reserved				Analog Input Data Channel 3												
5	URo1	URo0	ORo1	ORo0	OW3	OW2	OW1	OW0	ORi3	ORi2	ORi1	ORi0	Reserved	RF	UF		

UF	Module Unrecoverable Fault	Set "0": No Error	Set "1": Error
RF	Module Recoverable Fault	Set "0": No Error	Set "1": Error
ORi x	Over Range Input Channel	Set "0": No Over Range	Set "1": Over Range
OW x	Input Open Wire (@ 4-20mA Range)	Set "0": No Open Wire	Set "1": Open Wire
ORo x	Output Data Over Range	Set "0": No Over Range	Set "1": Over Range
URo x	Output Data Under Range (@4-20MA Range)	Set "0": No Under Range	Set "1": Under Range

Maximum Output Data Format (Base Modules -4B4P)

Word	Bit Position																
	15	14	13	12	11	10	9	8	7	6	5	4	3	2	1	0	
0	Reserved												O3	O2	O1	O0	Base
1	Reserved				Analog Output Data Channel 0												
2	Reserved				Analog Output Data Channel 1												
3	OE	HLS	R	IF	IR3	IR2	IR1	IR0	IM3	IM2	IM1	IM0	OR1	OR0	OM1	OM0	
4	Reserved																
5	Reserved																
OM x	Output Mode Selection				Set "0": Voltage Mode				Set "1": Current Mode								
OR x	Output Range Selection on Current Mode				Set "0": 4-20mA				Set "1": 0-20mA								
IM x	Input Channel Mode Select				Set "0": Voltage Mode				Set "1": Current Mode								
IR x	Input Range Select on Current Mode				Set "0": 4-20mA				Set "1": 0-20mA								
R	Input Filter Selection				Set "0": 50Hz				Set "1": 60Hz								
HLS	Reserved				Set "0": Output Reset				Set "1": Hold Last State								
OE	HLS/OFF				Set "0": Output Disabled				Set "1": Output Enabled								
	Output Enable				(Output is 0mA at 0-20mA mode and 4-20mA mode and 0V at 0-10V mode when this bit is 0)												

Troubleshoot with the Indicators

The 1791R I/O module has the following indicators:

- Status indicator - base only
- Comm indicator - base only
- I/O status indicators - base and expansion

Status Indicator

Indication:	Status:
Off	No power
Red	Hardware or software error, power is low
Green	Normal operation
Flashing Red	Comm failure 1*
Flashing Red/Orange	Expansion error

*1 Comm fail = communication cable disconnected, 100ms between valid frames, no more than 255 valid frames between valid frames addressed to module, 20ms idle time exceeded.

**2 COMM and STATUS will alternately flash when processor restart lockout is selected, a fault has occurred and the processor is communicating with the module.

32 CompactBlock Distributed I/O on Remote I/O Series D

Comm Status Indicator	
Indication:	Status:
Off	Communication not established
Green	Communication established
Flashing Green	Processor in Program mode

I/O Status Indicators			
Function:	LED Color:	Module Illumination:	Condition:
Outputs	Each output: Yellow	None Yellow	Output not energized Output energized
Inputs	Each Input: Yellow	None Yellow	No valid input Valid input

Specifications

Sinking or Sourcing Input Specifications	
Inputs per block	groups of 4 or 8
Off-state Voltage	5V dc maximum
On-state Voltage	30V dc @ 40°C maximum 25V dc @ 60°C maximum 10V dc minimum
Off-state Current	1.5mA minimum
On-state Current	11mA @ 30V dc maximum 2mA @ 10V dc minimum
Sinking or Sourcing Output Specifications	
Outputs per block	groups of 4 or 8
On-state Voltage Range	10 - 30V dc
On-state Voltage Drop	0.5V dc @ rated current
On-state Current	0.5A maximum
Off-state Leakage	1.0mA maximum
Module Current (per output)	0.5A maximum

Sinking or Sourcing Output Specifications (continued)

Surge Current - for 10 mS repeatable every 2 S	1.0A maximum
Indicators	Status - red/green/orange Comm - green I/O - yellow
Communication Rate	57.6Kbps @ 3048m (10000ft) 115.2Kbps @ 1524m (5000ft) 230.4Kbps @ 762m (2500ft)

General Specifications

Isolation Auxiliary I/O power to RIO I/O group-to-group I/O group-to-RIO		Type tested to 500V ac for 60 seconds Type tested to 500V ac for 60 seconds Type tested to 500V ac for 60 seconds
Isolation Auxiliary I/O power to RIO I/O group-to-group I/O group-to-RIO		Type tested to 500V ac for 60 seconds Type tested to 500V ac for 60 seconds Type tested to 500V ac for 60 seconds
RIO Power:	Voltage Current	18 - 26.4V dc 250mA maximum (with expansion)
Expansion Power:	Voltage Current	5V dc 100mA
Auxiliary Power Inputs:	Voltage Current	10-30V dc 88mA each group of 8
Auxiliary Power Outputs:	Voltage Current	10-30V dc 4A each group of 8
Base Module Dimensions		150mm X 50mm X 38mm 5.91in X 1.97in X 1.5in
Expansion Module Dimensions		115mm X 50mm X 38mm 4.4in X 1.97in X 1.5in
Field Wiring Tightening Torque		5-7lb-in. (0.5-0.6 Nm)
Operating Temperature		IEC 60068-2-1 (Test Ad, Operating Cold), IEC 60068-2-2 (Test Bd, Operating Dry Heat), IEC 60068-2-14 (Test Nb, Operating Thermal Shock): 0 to 60°C (32 to 140°F)

34 CompactBlock Distributed I/O on Remote I/O Series D

General Specifications	
Storage Temperature	IEC 60068-2-1 (Test Ab, Un-packaged Non-operating Cold), IEC 60068-2-2 (Test Bb, Un-packaged Non-operating Dry Heat), IEC 60068-2-14 (Test Na, Un-packaged Non-operating Thermal Shock): -40 to 85°C (-40 to 185°F)
Relative Humidity	IEC 60068-2-30 (Test Db, Un-packaged Non-operating Damp Heat): 5-95% non-condensing
Shock	IEC60068-2-27 (Test Ea, Unpackaged Shock): Operating 30g Non-operating 50g
Vibration	IEC60068-2-6 (Test Fc, Operating): 5g @ 10-500Hz
Conductors Wire Size Category	14 gauge (2mm ²) stranded maximum 3/64 inch insulation maximum 2 ^{1,2}
ESD Immunity	IEC 61000-4-2: 6kV contact discharge 8kV air discharge
Radiated RF Immunity	IEC 61000-4-3: 10V/m with 1kHz sine-wave 80%AM from 80MHz to 1000MHz 10V/m with 200Hz 50% Pulse 100%AM at 900Mhz
EFT/B Immunity	IEC 61000-4-4: ±2kV at 5kHz on signal ports ±2kV at 5kHz on communications ports
Surge Transient Immunity	IEC 61000-4-5: ±1kV line-line(DM) and ±2kV line-earth(CM) on signal ports ±2kV line-earth(CM) on shielded ports
Conducted RF Immunity	IEC 61000-4-6: 10Vrms with 1kHz sine-wave 80%AM from 150kHz to 80MHz
Emissions	CSPR 11: Group 1, Class A

General Specifications (continued)

Certifications: (when product is marked)	c-UL-us UL Listed Industrial Control Equipment, certified for US and Canada c-UL-us UL Listed for Class I, Division 2 Group A,B,C,D Hazardous Locations, certified for U.S. and Canada CE ³ European Union 89/336/EEC EMC Directive, compliant with: EN 61000-6-4; Industrial Emissions EN 50082-2; Industrial Immunity EN 61326; Meas./Control/Lab., Industrial Requirements 61000-6-2; Industrial Immunity C-Tick ³ Australian Radiocommunications Act, compliant with: AS/NZS CISPR 11; Industrial Emissions
Enclosure	Meets IP20



1. You use this conductor category information for planning conductor routing as described in the system level installation manual.
2. See publication 1770-4.1, "Programmable Controller Wiring and Grounding Guidelines."
3. See the Product Certification link at www.ab.com for Declarations of Conformity, Certificates, and other certification details.

IMPORTANT

Input and output wiring must be in accordance with Class 1, Division 2 wiring methods and in accordance with the authority having jurisdiction.

CompactBlock is a trademark of Rockwell Automation, Allen-Bradley, Inc.

North American Hazardous Location Approval

<p>The following information applies when operating this equipment in hazardous locations:</p> <p>Products marked "CL I, DIV 2, GP A, B, C, D" are suitable for use in Class I Division 2 Groups A, B, C, D, Hazardous Locations and nonhazardous locations only. Each product is supplied with markings on the rating nameplate indicating the hazardous location temperature code. When combining products within a system, the most adverse temperature code (lowest "T" number) may be used to help determine the overall temperature code of the system. Combinations of equipment in your system are subject to investigation by the local Authority Having Jurisdiction at the time of installation.</p>		<p>Informations sur l'utilisation de cet équipement en environnements dangereux :</p> <p>Les produits marqués "CL I, DIV 2, GP A, B, C, D" ne conviennent qu'à une utilisation en environnements de Classe I Division 2 Groupes A, B, C, D dangereux et non dangereux. Chaque produit est livré avec des marquages sur sa plaque d'identification qui indiquent le code de température pour les environnements dangereux. Lorsque plusieurs produits sont combinés dans un système, le code de température le plus défavorable (code de température le plus faible) peut être utilisé pour déterminer le code de température global du système. Les combinaisons d'équipements dans le système sont sujettes à inspection par les autorités locales qualifiées au moment de l'installation.</p>	
<p>WARNING</p> 	<p>EXPLOSION HAZARD</p> <ul style="list-style-type: none"> Do not disconnect equipment unless power has been removed or the area is known to be nonhazardous. Do not disconnect connections to this equipment unless power has been removed or the area is known to be nonhazardous. Secure any external connections that mate to this equipment by using screws, sliding latches, threaded connectors, or other means provided with this product. Substitution of components may impair suitability for Class I, Division 2. If this product contains batteries, they must only be changed in an area known to be nonhazardous. 	<p>AVERTISSEMENT</p> 	<p>RISQUE D'EXPLOSION</p> <ul style="list-style-type: none"> Couper le courant ou s'assurer que l'environnement est classé non dangereux avant de débrancher l'équipement. Couper le courant ou s'assurer que l'environnement est classé non dangereux avant de débrancher les connecteurs. Fixer tous les connecteurs externes reliés à cet équipement à l'aide de vis, loquets coulissants, connecteurs filetés ou autres moyens fournis avec ce produit. La substitution de composants peut rendre cet équipement inadapté à une utilisation en environnement de Classe I, Division 2. S'assurer que l'environnement est classé non dangereux avant de changer les piles.

www.rockwellautomation.com

Power, Control and Information Solutions Headquarters

Americas: Rockwell Automation, 1201 South Second Street, Milwaukee, WI 53204-2496 USA, Tel: (1) 414-382.2000, Fax: (1) 414-382.4444
 Europe/Middle East/Africa: Rockwell Automation, Vorstlaan/Boulevard du Souverain 36, 1170 Brussels, Belgium, Tel: (32) 2 663 0600, Fax: (32) 2 663 0640
 Asia Pacific: Rockwell Automation, Level 14, Core F, Cyberport 3, 100 Cyberport Road, Hong Kong, Tel: (852) 2887 4788, Fax: (852) 2508 1846

Publication 1791R-IN002B-EN-P - August 2003

PN 957831-14

Supersedes Publication 1791D-IN002A-EN-P - June 2003

Copyright © 2003 Rockwell Automation, Inc. All rights reserved. Printed in the U.S.A.