



DeviceNet Digital Base Terminal Block CompactBlock LDX I/O

Catalog Numbers 1790D-T16BV0, 1790D-T8BV8V,
1790D-T8BV8B, 1790D-T0B16, 1790D-T0V16, 1790D-T0W6,
1790D-T8A0, 1790D-T0A6

Table of Contents

Topic	Page
Important User Information	2
Environment and Enclosure	3
Prevent Electrostatic Discharge	3
North American Hazardous Location Approval	5
Before You Begin	5
Install the Base Block	6
Set the Node Address on the Base Block	6
Mount the Optional Expansion Block	9
Wiring the Terminal Block	10
Interpret the Status Indicators	15
Cable Break Procedures	16
Specifications	17

Important User Information

Solid-state equipment has operational characteristics differing from those of electromechanical equipment. Safety Guidelines for the Application, Installation and Maintenance of Solid State Controls (Publication [SGI-1.1](#) available from your local Rockwell Automation sales office or online at <http://www.rockwellautomation.com/literature/>) describes some important differences between solid-state equipment and hard-wired electromechanical devices. Because of this difference, and also because of the wide variety of uses for solid-state equipment, all persons responsible for applying this equipment must satisfy themselves that each intended application of this equipment is acceptable.





In no event will Rockwell Automation, Inc. be responsible or liable for indirect or consequential damages resulting from the use or application of this equipment.

The examples and diagrams in this manual are included solely for illustrative purposes. Because of the many variables and requirements associated with any particular installation, Rockwell Automation, Inc. cannot assume responsibility or liability for actual use based on the examples and diagrams.

No patent liability is assumed by Rockwell Automation, Inc. with respect to use of information, circuits, equipment, or software described in this manual.

Reproduction of the contents of this manual, in whole or in part, without written permission of Rockwell Automation, Inc., is prohibited.

Throughout this manual, when necessary, we use notes to make you aware of safety considerations.

	WARNING: Identifies information about practices or circumstances that can cause an explosion in a hazardous environment, which may lead to personal injury or death, property damage, or economic loss.
	ATTENTION: Identifies information about practices or circumstances that can lead to personal injury or death, property damage, or economic loss. Attentions help you identify a hazard, avoid a hazard and recognize the consequences.
	SHOCK HAZARD: Labels may be on or inside the equipment (for example, drive or motor) to alert people that dangerous voltage may be present.
	BURN HAZARD: Labels may be on or inside the equipment (for example, drive or motor) to alert people that surfaces may reach dangerous temperatures.
IMPORTANT	Identifies information that is critical for successful application and understanding of the product.

Environment and Enclosure



ATTENTION: This equipment is intended for use in a Pollution Degree 2 industrial environment, in overvoltage Category II applications (as defined in IEC publication 60664-1), at altitudes up to 2000 meters (6562 ft) without derating.

This equipment is considered Group 1, Class A industrial equipment according to IEC/CISPR Publication 11. Without appropriate precautions, there may be potential difficulties ensuring electromagnetic compatibility in other environments due to conducted as well as radiated disturbance.

This equipment is supplied as open-type equipment. It must be mounted within an enclosure that is suitably designed for those specific environmental conditions that will be present and appropriately designed to prevent personal injury resulting from accessibility to live parts. The enclosure must have suitable flame-retardant properties to prevent or minimize the spread of flame, complying with a flame spread rating of 5VA, V2, V1, V0 (or equivalent) if non-metallic. The interior of the enclosure must be accessible only by the use of a tool. Subsequent sections of this publication may contain additional information regarding specific enclosure type ratings that are required to comply with certain product safety certifications.

In addition to this publication, see:

- Industrial Automation Wiring and Grounding Guidelines, for additional installation requirements, Allen-Bradley publication [1770-4.1](#).
- NEMA Standards publication 250 and IEC publication 60529, as applicable, for explanations of the degrees of protection provided by different types of enclosure.

Prevent Electrostatic Discharge



ATTENTION: This equipment is sensitive to electrostatic discharge, which can cause internal damage and affect normal operation. Follow these guidelines when you handle this equipment:

- Touch a grounded object to discharge potential static.
- Wear an approved grounding wriststrap.
- Do not touch connectors or pins on component boards.
- Do not touch circuit components inside the equipment.
- Use a static-safe workstation, if available.
- Store the equipment in appropriate static-safe packaging when not in use.



WARNING: If you connect or disconnect the communications cable with power applied to this module or any device on the network, an electrical arc can occur. This could cause an explosion in hazardous location installations. Be sure that power is removed or the area is nonhazardous before proceeding.



WARNING: If you connect or disconnect wiring while the field-side power is on, an electrical arc can occur. This could cause an explosion in hazardous location installations. Be sure that power is removed or the area is nonhazardous before proceeding.





ATTENTION: To comply with the CE Low Voltage Directive (LVD), all wiring connections to this equipment must be powered from a source compliant with the following:
Safety Extra Low Voltage (SELV) or Protected Extra Low Voltage (PELV).



ATTENTION: To comply with UL restrictions, DeviceNet must be powered from a source compliant with the following:
Class 2 or Limited Voltage/Current.

North American Hazardous Location Approval

<p>The following information applies when operating this equipment in hazardous locations:</p>	<p>Informations sur l'utilisation de cet équipement en environnements dangereux:</p>
<p>Products marked "CL I, DIV 2, GP A, B, C, D" are suitable for use in Class I Division 2 Groups A, B, C, D, Hazardous Locations and nonhazardous locations only. Each product is supplied with markings on the rating nameplate indicating the hazardous location temperature code. When combining products within a system, the most adverse temperature code (lowest "T" number) may be used to help determine the overall temperature code of the system. Combinations of equipment in your system are subject to investigation by the local Authority Having Jurisdiction at the time of installation.</p>	<p>Les produits marqués "CL I, DIV 2, GP A, B, C, D" ne conviennent qu'à une utilisation en environnements de Classe I Division 2 Groupes A, B, C, D dangereux et non dangereux. Chaque produit est livré avec des marquages sur sa plaque d'identification qui indiquent le code de température pour les environnements dangereux. Lorsque plusieurs produits sont combinés dans un système, le code de température le plus défavorable (code de température le plus faible) peut être utilisé pour déterminer le code de température global du système. Les combinaisons d'équipements dans le système sont sujettes à inspection par les autorités locales qualifiées au moment de l'installation.</p>
<div style="display: flex; align-items: center;">  <div> <p>EXPLOSION HAZARD</p> <ul style="list-style-type: none"> • Do not disconnect equipment unless power has been removed or the area is known to be nonhazardous. • Do not disconnect connections to this equipment unless power has been removed or the area is known to be nonhazardous. Secure any external connections that mate to this equipment by using screws, sliding latches, threaded connectors, or other means provided with this product. • Substitution of components may impair suitability for Class I, Division 2. • If this product contains batteries, they must only be changed in an area known to be nonhazardous. </div> </div>	<div style="display: flex; align-items: center;">  <div> <p>RISQUE D'EXPLOSION</p> <ul style="list-style-type: none"> • Couper le courant ou s'assurer que l'environnement est classé non dangereux avant de débrancher l'équipement. • Couper le courant ou s'assurer que l'environnement est classé non dangereux avant de débrancher les connecteurs. Fixer tous les connecteurs externes reliés à cet équipement à l'aide de vis, loquets coulissants, connecteurs filetés ou autres moyens fournis avec ce produit. • La substitution de composants peut rendre cet équipement inadapté à une utilisation en environnement de Classe I, Division 2. • S'assurer que l'environnement est classé non dangereux avant de changer les piles. </div> </div>

Before You Begin

Read this section about important CompactBlock I/O requirements.

Current functions of CompactBlock LDX I/O blocks require the current, modular electronic data sheet (EDS) file for RSNetWorx for DeviceNet software, version 8.0 or later. These files are available online at <http://www.ab.com/networks/eds/>.

EDS files for blocks with matching catalog numbers for both D-shell and terminal block versions are the same. On the website and in RSNetWorx for DeviceNet software, find the EDS file for both versions of the blocks. For example, for the EDS file for 1790D-T8BV8B blocks, use the EDS file labelled 1790D-8BV8B.

Install the Base Block

To install the base block:

- set the node address on the base block.
- mount the base block.
- mount the optional expansion blocks.
- wire the terminal block.
- connect the DeviceNet cable.

Set the Node Address on the Base Block

When setting the node address on the base block, note that each base block comes with its internal program set for node address 63. To reset the node address, adjust the switches on the front of the base block. The two switches are most significant digit (MSD) and least significant digit (LSD). You can set switches to 00...63.

Node Address Example

Example: Node
Address is set at 11

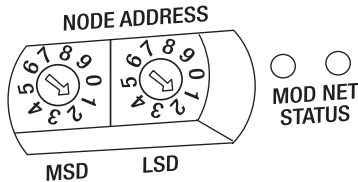

The base block reads the rotary switches at power up only. Switch settings between 64 and 99 cause the block to use the last valid node address stored internally.

You can also set the node address through RSNetWorx for DeviceNet software or a similar configuration tool.

When you use software configuration for the node address, set the switches to 64...99.

Mount the Base Module

Mount the base block to a panel or DIN rail. We recommend that you ground the panel or DIN rail before mounting the block.

Dimensions

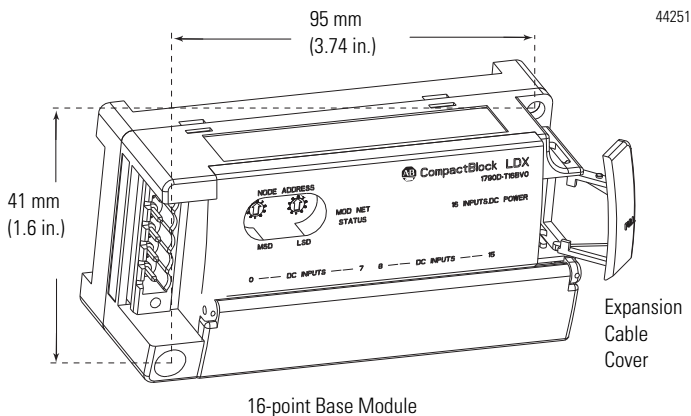

16-point Base Module

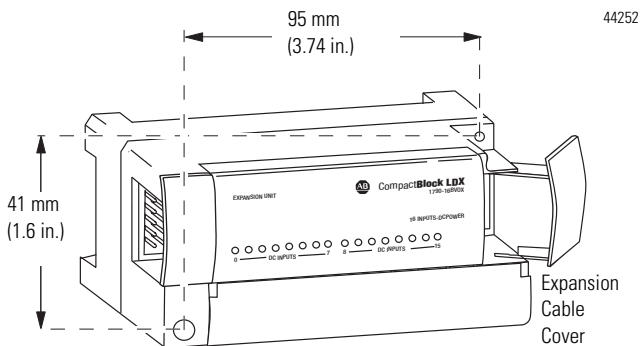

16-point Expansion Module

Mount on a Panel

For panel mounting, use these steps.

1. Place the block against the panel where you want it mounted.
2. Gently pull and position the expansion cover to the left.
3. Place a center punch, nail, or similar device through the mounting holes in the block and make two marks on the panel at the lower-left and upper-right corners of the module.
4. Remove the block and drill two holes in the panel to accommodate each of the mounting screws.
5. Replace the block on the panel and place a screw through each of the two mounting holes.
6. Tighten the screws until the block is firmly in place.

Mount on DIN Rail

For DIN-rail mounting, use these steps.

1. Hook the top slot of the base block over the DIN rail.

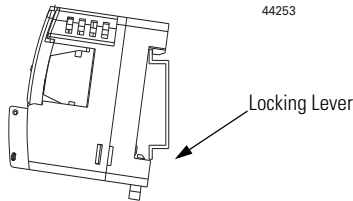

2. Pull down on the locking lever while pressing the base block against the rail.
3. Push up on the locking lever to secure the base block to the rail when the base block is flush against the rail.

Mount the Optional Expansion Block

To mount the optional expansion block, use these steps.

1. Mount the expansion block by connecting it to a previously-installed CompactBlock LDX I/O base or expansion block.
2. Beginning with the base block, mount your expansion block either horizontally or vertically.
 - To mount horizontally (left to right), add an expansion block in an end-to-end configuration.

44372

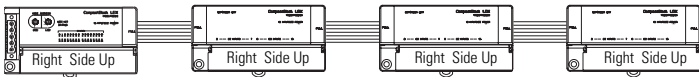

- To mount vertically (up or down), add an expansion block either up or down in a back-to-back configuration. In this configuration, you must use the optional 15 cm (5.9 in.) ribbon cable, catalog number 1790-15CMCBL, and alternately position the block in a right-side up, upside-down fashion.

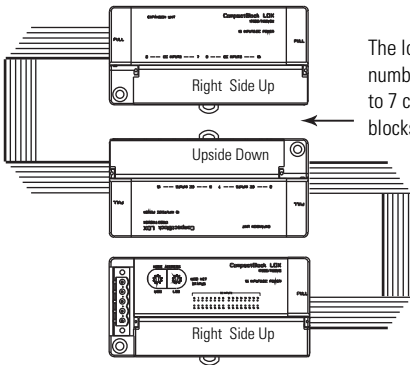

The longer expansion cable, catalog number 1790-15CMCBL, provides for up to 7 cm (2.76 in.) of space between blocks.

44373

3. Mount your block on a panel or DIN rail.

Wiring the Terminal Block



WARNING: If you connect or disconnect wiring while the field-side power is on, an electrical arc can occur. This could cause an explosion in hazardous location installations. Be sure that power is removed or the area is nonhazardous before proceeding.

See the diagrams that follow for wiring information.

1790D-T16BVO Input Base Block Wiring Diagram

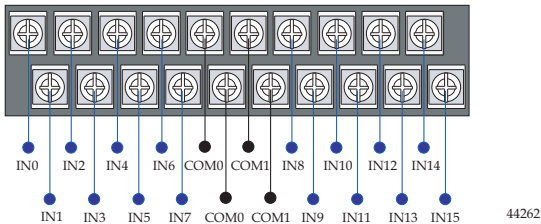

- For inputs 0...7: For sinking inputs, wire COM 0 to Field Power (-) GND. For sourcing inputs, wire COM 0 to Field Power (+) 24V DC.
- For inputs 8...15: For sinking inputs, wire COM 1 to Field Power (-) GND. For sourcing inputs, wire COM 1 to Field Power (+) 24V DC. Note that both COM 0 and COM 1 are internally connected.

1790D-T8BV8V Input/Output Base Block Wiring Diagram

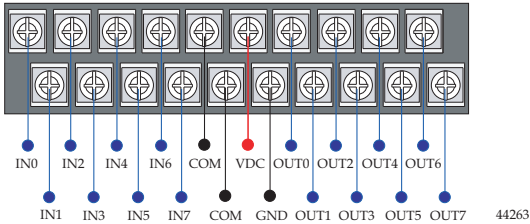

- For sinking inputs, wire COM to Field Power (-) GND.
For sourcing inputs, wire COM to Field Power (+) 24V DC.
Note that both COM are internally connected.
- For sinking outputs, wire V DC to Field Power (+) 24V DC, and wire GND to Field Power (-) GND.

1790D-T8BV8B Input/Output Base Block Wiring Diagram

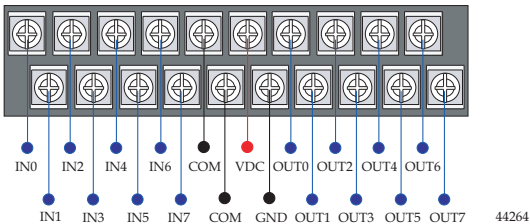

- For sinking inputs, wire COM to Field Power (-) GND.
For sourcing inputs, wire COM to Field Power (+) 24V DC.
Note that COM are internally connected.
- For sourcing outputs, wire V DC to Field Power (+) 24V DC, and wire GND to Field Power (-) GND.

1790D-T0B16 Output Base Block Wiring Diagram

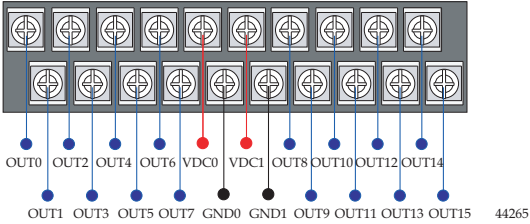

- For sourcing outputs, wire V DC 0 and V DC 1 to Field Power (+) 24V DC, and wire GND0 and GND1 to Field Power (-) GND.

1790D-T0V16 Output Base Block Wiring Diagram

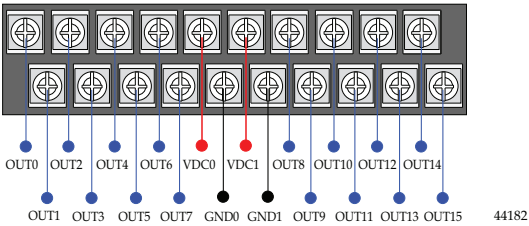

- For sinking outputs, wire V DC 0 (pin 9) and V DC 1 (pin 11) to Field Power (+) 24V DC, and wire GND0 (pin 10) and GND1 (pin 12) to Field Power (-) GND.

1790D-T0W6 Relay Output Base Block Wiring Diagram

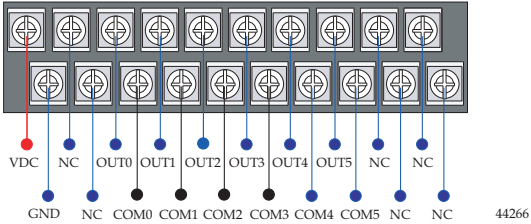

- Wire V DC to Field Power (+) 24V DC.
Wire GND to Field Power (-) GND.

1790D-T8A0 AC Input Base Block Wiring Diagram

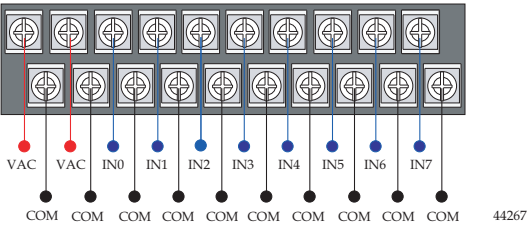

- Wire 120V AC Field Power to V AC and COM.
Note that all V AC are internally connected. All COM are internally connected.

1790D-T0A6 AC Output Base Block Wiring Diagram

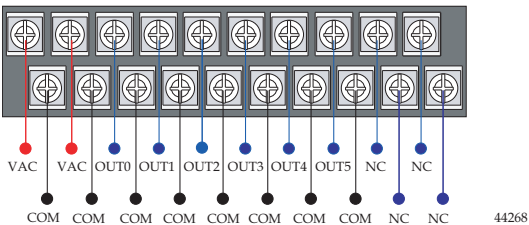

- Wire 120V AC Field Power to V AC and COM.
Note that all V AC are internally connected. All COM are internally connected.

Connect the DeviceNet Cable

Follow these procedures to connect the DeviceNet cable to the base block. The DeviceNet connector is not supplied with the base block. You must purchase the connector separately. These are the types of connectors you order directly from Rockwell Automation.

- 1799-DNETCON – 5-position open-style connector
- 1799-DNETSCON – 5-position open-style connector with locking screws
- 1799-DNC5MMS – 5-position open-style to 12 mm (0.47 in.) connector with locking screws



WARNING: If you connect or disconnect the communication cable with power applied to this module or any device on the network, an electrical arc can occur. This could cause an explosion in hazardous location installations.

Be sure that power is removed or the area is nonhazardous before proceeding

1. Connect the DeviceNet wiring (drop line) to one of the DeviceNet connectors as shown in the figure, noting that a color-coded wiring diagram is printed next to the connector on the left side of the base block.

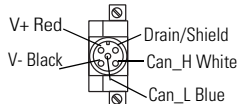
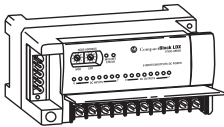

Wiring Diagram for
1799-DNETCON
Connector

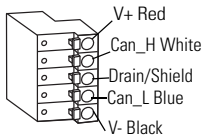

Wiring Diagram for
1799-DNC5MMS
Connector

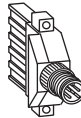

44164

1. Attach the connector to the base block once you have properly wired the drop line to the connector.
2. Use the locking screws on the connector to fasten it to the base block, if applicable.

Interpret the Status Indicators

Read this section for information about how to interpret base block status indicators. The base block has these status indicators:

- Block status
- Network status
- I/O status

If a module status indicator is flashing red, refer to the cable break procedures section.

Status Indicators

Indicator	Status	Description
Module	Solid red	Unrecoverable fault in base unit. Replace base block.
	Flashing red	Fault in expansion unit, or Node address switches do not match current node address. Reconnect or replace, as needed.
	Solid green	Normal operation.
	Off	No power. Apply power to device.
Network	Solid red	Module node number is a duplicate of an existing node, or network communication issues exist. Change module node number to an unused address, or verify network wiring is correct and communication is stable.
	Flashing red	An I/O connection has timed out. Cycle power to the module.
	Solid green	The module is operating in a normal condition, and the module is online with connections in the established state. As a group 2 module, the module is allocated to a master.

Status Indicators

Indicator	Status	Description
Network	Flashing green	The module is online with no connections in the established state. Establish connections to other nodes. As a group 2 module, allocate the module to a master.
	Off	No power. Wait until the module has completed the dup_MAC_id test or power the module.

I/O Status Indicators

Indicator	Status	Description
Each output	None	Output is not energized.
	Green	Output is energized.
Each input	None	No valid input is present.
	Green	Valid input is present.

Cable Break Procedures

A cable break in any location between either of the following produces data of 0 in the data table for all inputs down stream of the cable break:

- Base and digital input expansion module
- Digital input expansion module and another digital input expansion module

All digital-expansion inputs produce data of 0 if the expansion cable is removed. No status is in the default produced assembly. Attribute 101 in the identity object reports module faults.

If no faults are present, an explicit message GET command returns 0.

If the ribbon cable is disconnected, it returns 0x04, which is for module location change. The module status indicator also flashes indicating a fault if an expansion is disconnected. Select an alternate produced assembly that contains the expansion status byte, using the EDS Properties configuration dialog.

Specifications

Universal DC Input Base Block - 1790D-T16BV0

Attribute	Value
Number of inputs	16
Input type	Sink, source 24V DC
Voltage, off-state input, max	5V DC
Voltage, on-state input, max	28.8V DC
Voltage, on-state input, nom	24V DC
Voltage, on-state input, min	9.6V DC
Current, off-state input, max	1.5 mA @ 5V DC
Current, on-state input, max	8 mA @ 28.8V DC per channel
Input impedance, nom	4.8 k Ω
Field power dissipation	3.68 W max @ 28.8V DC
DC field power	Supply voltage - 24V DC nom Voltage range - 10...28.8V DC

1790D-TOV16, 1790D-TOB16

Attribute	Value
Number of outputs, nonisolated	16, sinking (1790D-TOV16) 16, sourcing (1790D-TOB16)
Voltage, off-state output, max	28.8V DC
Voltage, on-state output, max	28.8V DC
Voltage, on-state output, nom	24V DC
Voltage, on-state output, min	10V DC
Voltage, on-state drop, max	0.5V DC
Current, on-state output, min	1 mA per channel
Leakage, off-state, max	0.5 mA
Output signal delay, off to on, max	0.5 ms
Output signal delay, on to off, max	1.0 ms

1790D-TOV16, 1790D-TOB16

Attribute	Value
Output current rating, output, max	0.5 A
Output current rating, common, max	4.0 A
Field power dissipation	2.76 W @ 28.8V DC
DC field power	Supply voltage - 24V DC nom Voltage range - 10...28.8V DC

1790D-T8BV8V, 1790D-T8BV8B

Attribute	Value
Number of inputs, non-isolated	8 points , sinking or sourcing
Voltage, off-state input, max	5.0V DC
Voltage, on-state input, max	28.8V DC
Voltage, on-state input, nom	24V DC
Voltage, on-state input, min	9.6V DC
Current, on-state, max	8 mA per channel @ 28.8V DC
Current, on-state, min	1 mA per channel
Input impedance, nom	4.8 k Ω
Number of outputs, non-isolated	8 points, sinking (1790D-T8BV8V) 8 points, sourcing (1790D-T8BV8B)
Voltage, on-state output, max	28.8V DC
Voltage, on-state output, nom	24V DC
Voltage, on-state output, min	10V DC
Voltage, on-state drop, max	0.5V DC
Output current rating, output, max	0.5 A
Output current rating, common, max	4.0 A
Leakage, off-state, max	0.5 mA
Output signal delay, off to on, max	0.5 ms

1790D-T8BV8V, 1790D-T8BV8B

Attribute	Value
Output signal delay, on to off, max	1.0 ms
Field power dissipation	3.22 W @ 28.8V DC
DC field power	Supply voltage - 24V DC nom Voltage range - 10...28.8V DC

1790D-TOW6

Attribute	Value
Relay type	Form A, normally open Single pole, single throw
Output voltage range (load dependent)	5...28V DC @ 2.0 A resistive 48V DC @ 0.8 A resistive 125V AC @ 2.0 A resistive 250V AC @ 2.0 A resistive
Load, min	100 μ A, 100 mV DC per point
On-state voltage drop, max	0.5V @ 2.0 A, resistive load, 24V DC
Initial contact resistance	30 milliohms
Expected contact life	300 kcycles resistive 100 kcycles inductive
Off-state leakage, max	1.5 mA
Output delay time, on to off, max	10 ms
Output delay time, off to on, max	10 ms
Relay coil power dissipation	1.7 W @ 28.8V DC
DC relay coil power	Supply voltage - 24V DC nom Voltage range - 19.2...28.8V DC

1790D-T8A0

Attribute	Value
Number of inputs, non-isolated	8
Voltage, on-state input, max	132V AC
Voltage, on-state input, nom	120V AC

1790D-T8A0

Attribute	Value
Voltage, on-state input, min	85V AC
Voltage, on-state drop, max	0.5V DC
Current, on-state input, max	9 mA
Current, off-state input, max	45V AC
Input signal delay, off to on, max	10 ms
Input signal delay, on to off, max	30 ms
Input impedance	18 k Ω
Field power dissipation	3VA @ 132V AC
AC field power	Supply voltage - 120V AC, 60 Hz Voltage range - 15...132V AC, 47...60 Hz

1790D-T0A6

Attribute	Value
Number of outputs, nonisolated	6
Load voltage range	15...132V AC
Load current, max	0.5 A rms
Load current, min	10 mA rms
Off-state Leakage current, max	1.0 mA rms @ 100V rms 60 Hz
On-state voltage drop, max	1.3V rms @ max load
Operate time, max	1 ms
Release, max	1/2 cycle + 1 ms
Insulation resistance	1,000 MW min (for input-output)
Input signal delay, off to on	10 ms
Input signal delay, on to off, max	30 ms
Field power dissipation	3.9VA @ rated current
AC field power	Supply voltage - 120V AC, 60 Hz Voltage range - 15...132V AC, 60 Hz

General Specifications

Attribute	Value
DeviceNet power	Supply voltage - 24V DC nom Voltage range - 10...25V DC
DeviceNet power dissipation	1.2 W max @ 25V DC
Network length	500 m (1640 ft) max @ 125 Kbps 100 m (328 ft) max @ 500 Kbps
Network protocol	Slave messaging: <ul style="list-style-type: none"> • Poll command • Bit Strobe command • Cyclic command • COS command
Status indicators	Module Status - red/green Network Status - red/green
Number of nodes	64 max - rotary switch-type node address setting
Communication rate	125 Kbps, 250 Kbps, 500 Kbps - auto baud rate selection
Dimensions (HxWxD), approx.	16pt base blocks: 52 x 104 x 42 mm (2.03 x 4.07 x 1.64 in.)
Weight, approx.	16pt base blocks: 0.1 kg (0.3 lb)
Enclosure type rating	Meets IP20
Isolation voltage	120V AC (continuous), Reinforced Insulation Type tested at 1250 V AC for 60 seconds, I/O to system No isolation between individual I/O channels (1790D-T0A6, -T0W6, and T8A0) 50V DC (continuous), Reinforced Insulation Type tested at 1250 V AC for 60 seconds, I/O to system No isolation between individual I/O channels (1790D-T8BV8B, T8BV8V, T16BV0, T0B16, and T0V16)
Mounting	DIN rail or panel
Wire size	0.25... 2.5 mm ² (22...14 AWG) solid or stranded copper wire rated at 75 °C (167 °F) or greater 1.2 mm (3/64 in.) insulation max
Wiring terminal screw torque, max	0.6 Nm (5.2 lb-in.)
Removable terminal block screw torque, max	0.56 Nm (5.0 lb-in.)

General Specifications

Attribute	Value
Wiring category ⁽¹⁾	2 - on signal ports 2 - on communication ports
Pilot duty rating	Not Rated
North American temperature code	T5

⁽¹⁾ Use this conductor category information for planning conductor routing as described in Industrial Automation Wiring and Grounding Guidelines, publication [1770-4.1](#).

Environmental Specifications

Attribute	Value
Temperature, operating	IEC 60068-2-1 (Test Ad, Operating Cold), IEC 60068-2-2 (Test Bd, Operating Dry Heat), IEC 60068-2-14 (Test Nb, Operating Thermal Shock): 0...60 °C (32...140 °F)
Temperature, storage	IEC 60068-2-1 (Test Ab, Unpackaged Non-operating Cold), IEC 60068-2-2 (Test Bb, Unpackaged Non-operating Dry Heat), IEC 60068-2-14 (Test Na, Unpackaged Non-operating Thermal Shock): -40...85 °C (-40...185 °F)
Relative humidity	IEC 60068-2-30 (Test Db, Unpackaged Damp Heat): 5...90% non-condensing
Vibration	IEC 60068-2-6 (Test Fc, Operating): 5 g @ 10...500 Hz
Shock, operating	IEC 60068-2-27 (Test Ea, Unpackaged Shock): 30 g
Shock, non-operating	IEC 60068-2-27 (Test Ea, Unpackaged Shock): 50 g
Emissions	CISPR 11: Group 1, Class A
ESD immunity	IEC 61000-4-2: 8 kV air discharges
Radiated RF immunity	IEC 61000-4-3: 10V/m with 1 kHz sine-wave 80%AM from 80...1000 MHz 10V/m with 1 kHz sine-wave 80%AM from 1.4...2 GHz 10V/m with 200 Hz 50% Pulse 100%AM at 900 MHz

Environmental Specifications

Attribute	Value
EFT/B immunity	IEC 61000-4-4: ±2 kV at 5 kHz on signal ports ±2 kV at 5 kHz on communications ports
Surge transient immunity	IEC 61000-4-5: ±1 kV line-line(DM) and ±2 kV line-earth(CM) on signal ports ±2 kV line-earth(CM) on communications ports
Conducted RF immunity	IEC 61000-4-6: 10V rms with 1 kHz sine-wave 80%AM from 150 kHz...80 MHz

Certifications

Certification (when product is marked) ⁽¹⁾	Value
c-UL-us	UL Listed Industrial Control Equipment, certified for US and Canada. See UL File E150833. UL Listed for Class I, Division 2 Group A,B,C,D Hazardous Locations, certified for U.S. and Canada. See UL File E195620.
CE	European Union 2004/108/EC EMC Directive, compliant with: EN 61326-1; Meas./Control/Lab., Industrial Requirements EN 61000-6-2; Industrial Immunity EN 61000-6-4; Industrial Emissions EN 61131-2; Programmable Controllers (Clause 8, Zone A & B) European Union 2006/95/EC LVD, compliant with: EN 61131-2; Programmable Controllers (Clause 11) (not for 1790D-T8BV8B, T8BV8V, T16BV0, T0B16, and T0V16)
RCM	Australian Radiocommunications Act, compliant with: AS/NZS CISPR11; Industrial Emissions
ODVA	ODVA conformance tested to DeviceNet specifications

⁽¹⁾ See the Product Certification link at <http://www.rockwellautomation.com/products/certification/> for Declaration of Conformity, Certificates, and other certification details.

Rockwell Automation Support

Rockwell Automation provides technical information on the Web to assist you in using its products. At <http://www.rockwellautomation.com/support/>, you can find technical manuals, a knowledge base of FAQs, technical and application notes, sample code and links to software service packs, and a MySupport feature that you can customize to make the best use of these tools.

For an additional level of technical phone support for installation, configuration and troubleshooting, we offer TechConnect support programs. For more information, contact your local distributor or Rockwell Automation representative, or visit <http://www.rockwellautomation.com/support/>.

Installation Assistance

If you experience a problem within the first 24 hours of installation, please review the information that's contained in this manual. You can also contact a special Customer Support number for initial help in getting your product up and running.

United States or Canada	1.440.646.3434
Outside United States or Canada	Use the Worldwide Locator at http://www.rockwellautomation.com/support/americas/phone_en.html , or contact your local Rockwell Automation representative.

New Product Satisfaction Return

Rockwell Automation tests all of its products to ensure that they are fully operational when shipped from the manufacturing facility. However, if your product is not functioning and needs to be returned, follow these procedures.

United States	Contact your distributor. You must provide a Customer Support case number (call the phone number above to obtain one) to your distributor to complete the return process.
Outside United States	Please contact your local Rockwell Automation representative for the return procedure.

Documentation Feedback

Your comments will help us serve your documentation needs better. If you have any suggestions on how to improve this document, complete this form, publication [RA-DU002](#), available at <http://www.rockwellautomation.com/literature/>.

Allen-Bradley, Rockwell Automation, CompactBlock LDX and RSNetWorx for DeviceNet, are trademarks of Rockwell Automation, Inc. DeviceNet is a trademark of Open DeviceNet Vendor Association.

Trademarks not belonging to Rockwell Automation are property of their respective companies.

Rockwell Otomasyon Ticaret A.Ş., Kar Plaza İş Merkezi E Blok Kat:6 34752 İçerenköy, İstanbul, Tel: +90 (216) 5698400

www.rockwellautomation.com

Power, Control and Information Solutions Headquarters

Americas: Rockwell Automation, 1201 South Second Street, Milwaukee, WI 53204-2496 USA, Tel: (1) 414.382.2000, Fax: (1) 414.382.4444
Europe/Middle East/Africa: Rockwell Automation, Vorstlaan/Boulevard du Souverain 36, 1170 Brussels, Belgium, Tel: (32) 2 663 0600, Fax: (32) 2 663 0640
Asia Pacific: Rockwell Automation, Level 14, Core F, Cyberport 3, 100 Cyberport Road, Hong Kong, Tel: (852) 2887 4788, Fax: (852) 2508 1846

Publication 1790-IN012C-EN-P - January 2015

PN-297576

Supersedes Publication 1790-IN012B-EN-P - July 2008

Copyright © 2015 Rockwell Automation, Inc. All rights reserved. Printed in Korea.