



## *Installation Instructions*

# DeviceNet Digital Base D-Shell Block CompactBlock LDX I/O

Catalog Numbers 1790D-16BV0, 1790D-8BV8V, 1790D-8BV8B,  
1790D-0B16, 1790D-0V16, 1790D-0W6, Series A

<b>Topic</b>	<b>Page</b>
Important User Information	2
Prevent Electrostatic Discharge	3
Environment and Enclosure	3
Power Supply	4
North American Hazardous Location Approval	5
Before You Begin	6
Install the Base Block	6
Set the Node Address	7
Mount the Base Block	8
Mount the Optional Expansion Block	9
Wire the TD-Shell Connectors	10
Connect the DeviceNet Cable	14
Interpret the LED Indicators	16
Specifications	19

### Important User Information

Solid state equipment has operational characteristics differing from those of electromechanical equipment. Safety Guidelines for the Application, Installation and Maintenance of Solid State Controls (publication SGI-1.1 available from your local Rockwell Automation sales office or online at <http://literature.rockwellautomation.com>) describes some important differences between solid state equipment and hard-wired electromechanical devices. Because of this difference, and also because of the wide variety of uses for solid state equipment, all persons responsible for applying this equipment must satisfy themselves that each intended application of this equipment is acceptable.





In no event will Rockwell Automation, Inc. be responsible or liable for indirect or consequential damages resulting from the use or application of this equipment.

The examples and diagrams in this manual are included solely for illustrative purposes. Because of the many variables and requirements associated with any particular installation, Rockwell Automation, Inc. cannot assume responsibility or liability for actual use based on the examples and diagrams.

No patent liability is assumed by Rockwell Automation, Inc. with respect to use of information, circuits, equipment, or software described in this manual.

Reproduction of the contents of this manual, in whole or in part, without written permission of Rockwell Automation, Inc., is prohibited.

Throughout this manual, when necessary, we use notes to make you aware of safety considerations.

<b>WARNING</b> 	Identifies information about practices or circumstances that can cause an explosion in a hazardous environment, which may lead to personal injury or death, property damage, or economic loss.
<b>IMPORTANT</b>	Identifies information that is critical for successful application and understanding of the product.
<b>ATTENTION</b> 	Identifies information about practices or circumstances that can lead to personal injury or death, property damage, or economic loss. Attentions help you to identify a hazard, avoid a hazard and recognize the consequences.
<b>SHOCK HAZARD</b> 	Labels may be located on or inside the equipment, for example, a drive or motor, to alert people that dangerous voltage may be present.
<b>BURN HAZARD</b> 	Labels may be located on or inside the equipment, for example, a drive or motor, to alert people that surfaces may be dangerous temperatures.

---

## Prevent Electrostatic Discharge

---

**ATTENTION**

This equipment is sensitive to electrostatic discharge, which can cause internal damage and affect normal operation. Follow these guidelines when you handle this equipment:

- Touch a grounded object to discharge potential static.
  - Wear an approved grounding wriststrap.
  - Do not touch connectors or pins on component boards.
  - Do not touch circuit components inside the equipment.
  - Use a static-safe workstation, if available.
  - Store the equipment in appropriate static-safe packaging when not in use.
- 

## Environment and Enclosure

---

**ATTENTION**

This equipment is intended for use in a Pollution Degree 2 industrial environment, in overvoltage Category II applications (as defined in IEC publication 60664-1), at altitudes up to 2000 m (6561 ft) without derating.

This equipment is considered Group 1, Class A industrial equipment according to IEC/CISPR Publication 11. Without appropriate precautions, there may be potential difficulties ensuring electromagnetic compatibility in other environments due to conducted as well as radiated disturbance.

This equipment is supplied as open-type equipment. It must be mounted within an enclosure that is suitably designed for those specific environmental conditions that will be present and appropriately designed to prevent personal injury resulting from accessibility to live parts. The interior of the enclosure must be accessible only by the use of a tool. Subsequent sections of this publication may contain additional information regarding specific enclosure-type ratings that are required to comply with certain product safety certifications.

Besides this publication, see:

- Industrial Automation Wiring and Grounding Guidelines, Allen-Bradley publication 1770-4.1, for additional installation requirements.
  - NEMA Standards publication 250 and IEC publication 60529, as applicable, for explanations of the degrees of protection provided by different types of enclosure.
-

### Power Supply

---

**ATTENTION**

1790D-0V16, 1790D-0B16

To comply with the CE Low Voltage Directive (LVD), the DeviceNet network and outputs must be powered from a source compliant with Safety Extra Low Voltage (SELV) or Protected Extra Low Voltage (PELV).

To comply with UL restrictions, the DeviceNet network and outputs must be powered from a source compliant with Class 2 or Limited Voltage/Current.

1790D-8BV8V, 1790D-8BV8B

To comply with the CE Low Voltage Directive (LVD), the DeviceNet network and I/O must be powered from a source compliant with Safety Extra Low Voltage (SELV) or Protected Extra Low Voltage (PELV). To comply with UL restrictions, the DeviceNet network and I/O must be powered from a source compliant with Class 2 or Limited Voltage/Current.

1790D-0W6



To comply with the CE Low Voltage Directive (LVD), the DeviceNet network and relay coil power must be powered from a source compliant with Safety Extra Low Voltage (SELV) or Protected Extra Low Voltage (PELV). To comply with UL restrictions, the DeviceNet network and relay coil must be powered from a source compliant with Class 2 or Limited Voltage/Current.

1790D-16BV0

To comply with the CE Low Voltage Directive (LVD), the DeviceNet network and output devices must be powered from a source compliant with Safety Extra Low Voltage (SELV) or Protected Extra Low Voltage (PELV). To comply with UL restrictions, the DeviceNet network and output devices must be powered from a source compliant with Class 2 or Limited Voltage/Current.

---

## North American Hazardous Location Approval

<p><b>The following information applies when operating this equipment in hazardous locations.</b></p>	<p><b>Informations sur l'utilisation de cet équipement en environnements dangereux.</b></p>
<p>Products marked CL I, DIV 2, GP A, B, C, D are suitable for use in Class I Division 2 Groups A, B, C, D, hazardous locations and nonhazardous locations only. Each product is supplied with markings on the rating nameplate indicating the hazardous location temperature code. When combining products within a system, the most adverse temperature code (lowest "T" number) may be used to help determine the overall temperature code of the system. Combinations of equipment in your system are subject to investigation by the local Authority Having Jurisdiction at the time of installation.</p>	<p>Les produits marqués CL I, DIV 2, GP A, B, C, D ne conviennent qu'à une utilisation en environnements de Classe I Division 2 Groupes A, B, C, D dangereux et non dangereux. Chaque produit est livré avec des marquages sur sa plaque d'identification qui indiquent le code de température pour les environnements dangereux. Lorsque plusieurs produits sont combinés dans un système, le code de température le plus défavorable (code de température le plus faible) peut être utilisé pour déterminer le code de température global du système. Les combinaisons d'équipements dans le système sont sujettes à inspection par les autorités locales qualifiées au moment de l'installation.</p>
<p><b>WARNING</b></p> 	<p><b>EXPLOSION HAZARD -</b></p> <ul style="list-style-type: none"> <li>• Do not disconnect equipment unless power has been removed or the area is known to be nonhazardous.</li> <li>• Do not disconnect connections to this equipment unless power has been removed or the area is known to be nonhazardous. Secure any external connections that mate to this equipment by using screws, sliding latches, threaded connectors, or other means provided with this product.</li> <li>• Substitution of components may impair suitability for Class I, Division 2.</li> <li>• If this product contains batteries, they must only be changed in an area known to be nonhazardous.</li> </ul>
<p><b>AVERTISSEMENT</b></p> 	<p><b>RISQUE D'EXPLOSION –</b></p> <ul style="list-style-type: none"> <li>• Couper le courant ou s'assurer que l'environnement est classé non dangereux avant de débrancher l'équipement.</li> <li>• Couper le courant ou s'assurer que l'environnement est classé non dangereux avant de débrancher les connecteurs. Fixer tous les connecteurs externes reliés à cet équipement à l'aide de vis, loquets coulissants, connecteurs filetés ou autres moyens fournis avec ce produit.</li> <li>• La substitution de composants peut rendre cet équipement inadapté à une utilisation en environnement de Classe 1, Division 2.</li> <li>• S'assurer que l'environnement est classé non dangereux avant de changer les piles.</li> </ul>

## Before You Begin

Read this section about CompactBlock LDX I/O block requirements.

Current functions of CompactBlock LDX I/O blocks require the current, modular electronic data sheet (EDS) file for RSNetWorx for DeviceNet software, version 3.0 or later. These files are available online at [www.ab.com/networks/eds/](http://www.ab.com/networks/eds/).

EDS files for blocks with matching catalog numbers for both D-Shell and terminal block versions are the same. On the Web site and in RSNetWorx for DeviceNet software, find the EDS file for both versions of the blocks. For example, for the EDS file for 1790D-T8BV8B blocks, use the EDS file labelled 1790D-8BV8B.

## Install the Base Block

To install the base block, follow these steps.

1. Set the node address on the base block.
2. Mount the base block.
3. Mount the optional expansion blocks.
4. Wire the terminal block.
5. Connect the DeviceNet cable.

## Set the Node Address

When setting the node address on the base block, note that each base block comes with its internal program set for node address 63.

To reset the node address, adjust the switches on the front of the base block. The two switches are most significant digit (MSD) and least significant digit (LSD). You can set switches between 00 and 63.

The base block reads the rotary switches only when power is applied. Switch settings between 64 and 99 cause the base block to use the last valid node address stored internally.

In this example, the node address setting is 11.

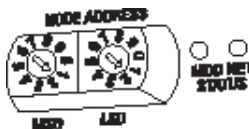

44152

You can also set the node address through RSNetWorx for DeviceNet software or a similar configuration tool.

When you use software configuration for the node address, set the switches between 64 and 99.

## Mount the Base Block

Mount the base block to a panel or DIN rail.

We recommend that you ground the panel or DIN rail before mounting the block.

---

**IMPORTANT**

The analog base module can accommodate a maximum of two digital expansion modules.

---

## Mount on a Panel

For panel mounting, use these steps.

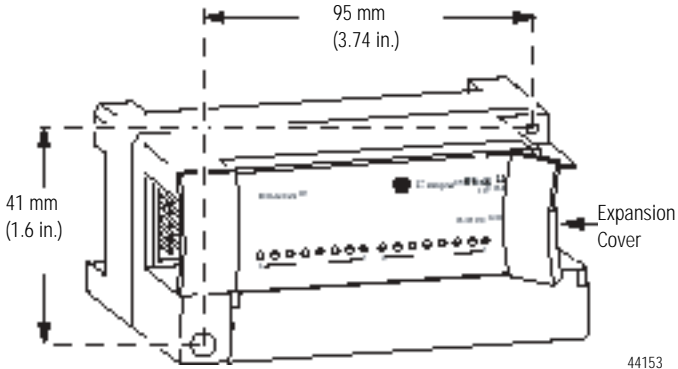

1. Place the block against the panel where you want it mounted.
2. Gently pull and position the expansion cover to the left.
3. Place a center punch, nail, or similar device through the mounting holes in the block and make two marks on the panel at the lower-left and upper-right corners of the module.



4. Remove the block and drill two holes in the panel to accommodate each of the mounting screws.
5. Replace the block on the panel and place a screw through each of the two mounting holes.
6. Tighten the screws until the block is firmly in place.

### Mount on DIN Rail

For DIN-rail mounting, use these steps.

1. Hook the top slot of the base block over the DIN rail.

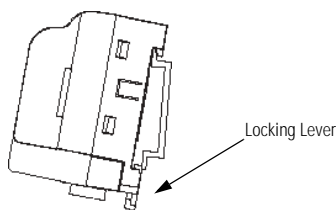

44154

2. Pull down on the locking lever while pressing the base block against the rail.
3. Push up on the locking lever to secure the base block to the rail when the base block is flush against the rail.

### Mount the Optional Expansion Block

Mount the expansion block by connecting it to a previously-installed CompactBlock LDX I/O base or expansion block.

Beginning with the base block, mount your expansion block either horizontally or vertically.

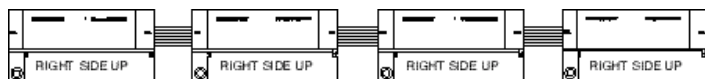

Horizontal Mounting

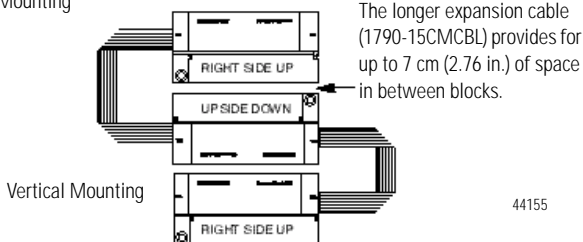

Vertical Mounting

44155

- To mount horizontally (left to right), add the expansion block in an end-to-end configuration.
- To mount vertically (up or down), add an expansion block either up or down in a back-to-back configuration. In this configuration, you must use the optional 15 cm (5.9 in.) ribbon cable (1790-15CMCBL) and alternately position the blocks in a right-side up, upside-down fashion.

Mount your blocks on a panel or DIN rail.

## Wire the TD-Shell Connectors

### WARNING



If you connect or disconnect wiring while the field-side power is on, an electrical arc can occur. This could cause an explosion in hazardous location installations. Be sure that power is removed or the area is nonhazardous before proceeding.

See the figures for wiring information.

### 1790D-16BVO Input Block Wiring Diagram

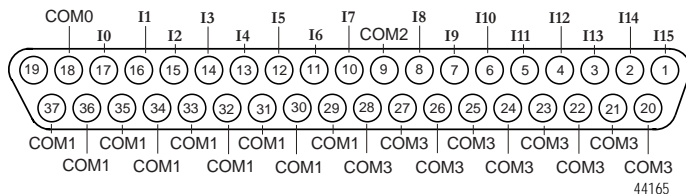

For inputs 0...7: For sinking inputs, wire Com 1 to Field Power (+) 24V dc and Com 0 to Field Power (-) GND. For sourcing inputs, wire Com 1 to Field Power (-) GND and Com 0 to Field Power (+) 24V dc.

For inputs 8...15: For sinking inputs, wire Com 3 to Field Power (+) 24V dc and Com 2 to Field Power (-) GND. For sourcing inputs, wire Com 3 to Field Power (-) GND and Com 2 to Field Power (+) 24V dc.

Note that all Com 1 and Com 3 are internally connected. Com 1 is used for inputs 0...7. Com 3 is used for inputs 8...15.

### 1790D-8BV8V Input/Output Wiring Diagram

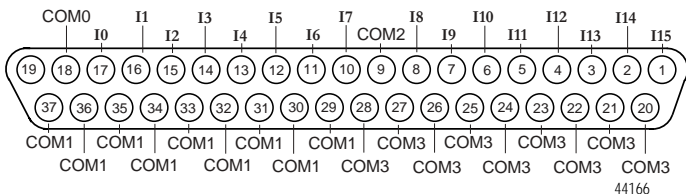

For sinking inputs, wire Com 1 to Field Power (+) 24V dc and Com 0 to Field Power (-) GND. For sourcing inputs, wire Com1 to Field Power (-) GND and Com 0 to Field Power (+) 24V dc. Note that all Com 1 are internally connected.

For sinking outputs, wire Com 2 to Field Power (+) 24Vdc, and Com 3 to Field Power (-) GND. Note that all Com 2 are internally connected.

**1790D-8BV8B Input/Output Block Wiring Diagram**

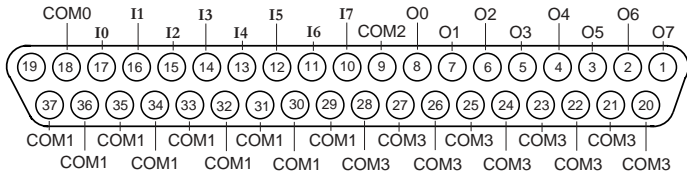

44167

For sinking inputs, wire Com 1 to Field Power (+) 24V dc and Com 0 to Field Power (-) GND. For sourcing inputs, wire Com 1 to Field Power (-) GND and Com 0 to Field (+) 24V dc. Note that all Com 1 are internally connected. For sourcing outputs, wire Com 2 to Field Power (+) 24Vdc and Com 3 to Field Power (-) GND . Note that all Com 3 are internally connected.

**1790D-0B16 Output Block Wiring Diagram**

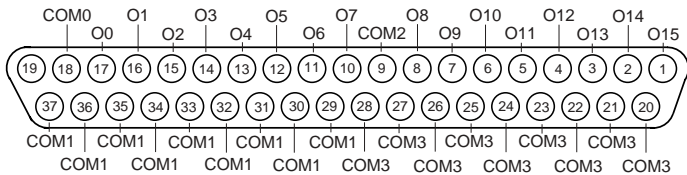

44168

For sourcing outputs, wire Com 0 and Com 2 to Field Power (+) 24V dc and Com 1 and Com 3 to Field Power (-) GND. Note that all Com 1 and Com 3 are internally connected.

### 1790D-0V16 Output Block Wiring Diagram

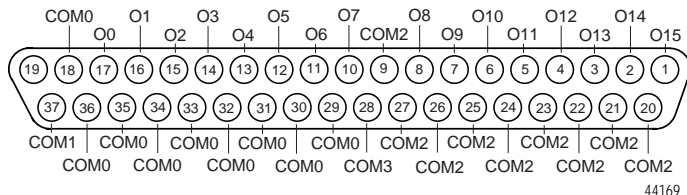

For sinking outputs, wire Com 0 and Com 2 to Field Power (+) 24V dc, and Com 1 and Com 3 to Field Power (-) GND.

Note that all Com 0 and Com 2 are internally connected.

### 1790D-0W6 Relay Output Block Wiring Diagram

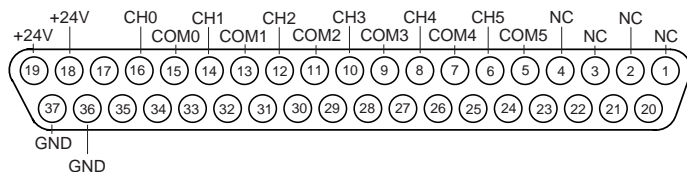

Wire pins 18 and 19 to Field Power (+) 24V dc.

Wire pins 36 and 37 to Field Power (-) GND.

## Connect the DeviceNet Cable

Follow these procedures to connect the DeviceNet cable to the base block. We do not supply the DeviceNet connector with the base block. You must purchase the connector separately. These are the types of connectors you order directly from Rockwell Automation.

- 1799-DNETCON - 5-position open style connector
- 1799-DNETSCON - 5-position open style connector with locking screws
- 1799-DNC5MMS - 5-position open style to 12 mm connector with locking screws

---

**WARNING**



If you connect or disconnect the DeviceNet cable with power applied to this module or any device on the network, an electrical arc can occur. This could cause an explosion in hazardous location installations.

Be sure that power is removed or the area is nonhazardous before proceeding.

---

1. Connect the DeviceNet wiring (drop line) to one of the DeviceNet connectors as shown in the figure, noting that a color-coded wiring diagram is printed next to the connector on the left side of the base block.

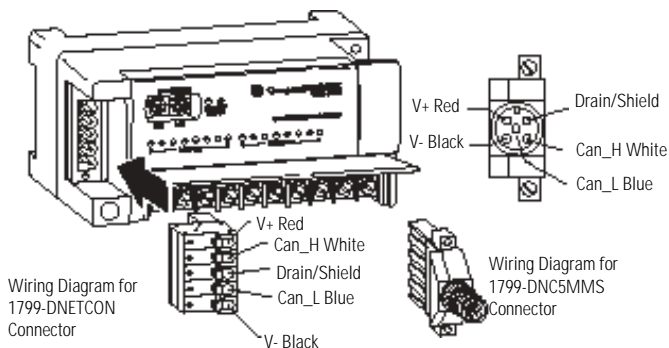

2. Attach the connector to the base block once you have properly wired the drop line to the connector.
3. Use the locking screws on the connector to fasten it to the base block, if applicable.

## Interpret the LED Indicators

Read this section for information about how to interpret block LED indicators and related procedures.

For a module status indicator that is flashing red, refer to the cable break procedure section.

The base block has the following indicators.

- Block status
- Network status
- I/O status

Indication	Probable Cause	Recommended Action
<b>Module Status</b>		
Solid Red	Unrecoverable fault in base unit.	Replace base block.
Flashing Red	Fault in expansion unit.	Replace expansion unit.
Solid Green	Normal operation.	None.
Off	No power.	Apply power to device.
<b>Network Status</b>		
Solid Red	Module node number is a duplicate of an existing node, or network communication issues exist.	Change module node number to an unused address, or verify network wiring is correct and communication is stable.
Flashing Red	An I/O connection has timed out.	Cycle power to the module.



Indication	Probable Cause	Recommended Action
Solid Green	The module is operating in a normal condition, and the module is online with connections in the established state. As a group 2 module, the module is allocated to a master.	None.
Flashing Green	The module is online with no connections in the established state.	Establish connections to other nodes. As a group 2 module, allocate the module to a master.
Off	No power.	Wait until the module has completed the dup_MAC_id test or power the module.

Function	LED Color	Module Illumination	Condition
<b>I/O Status</b>			
Outputs	Each output: Green	None Green	Output not energized. Output energized.
Inputs	Each input:: Green	None Green	No valid input. Valid input.

## Cable Break Procedure

A cable break in any location between either of the following produces data of 1 in the data table for all inputs down stream of the cable break.

- Base and digital input expansion module
- Digital input expansion module and another digital input expansion module

All digital-expansion inputs turn on if the expansion cable is removed. No status is in the produced assembly. Attribute 101 in the identity object reports module faults. If no faults are present, an explicit message GET command returns 0. If the ribbon cable is disconnected, it returns 0x04, which is for module location change.

The module LED also flashes indicating a fault if an expansion is disconnected. To determine if the data is valid, continuously send an explicit message to the module to check the status of the input conditions since no status word is in the I/O mapping data table.

- Class = 1
- Instance = 1
- Attribute = 101 (0x65)

To detect the loss of communication to the expansion module, use one of these methods.

- If an unused input is available, tie the unused input on the last expansion low. If that input goes high with a value of 1, a loss of communication to the expansion or expansions occurred.
- If no unused input is available, check expansion inputs for the condition of all on. To check validity in this case, send an explicit message to the identity object class 1, instance 1, attribute 101 (0x65). A returned value of 0 indicates the input data is good.

## Specifications

**IMPORTANT**

Input and output wiring must be in accordance with Class 1, Division 2 wiring methods and in accordance with the authority having jurisdiction..

### 1790D-16BVO Universal dc Input Base Block

Attribute	Value
Inputs per Module	16 point, sinking or sourcing
On-state Voltage	9.6V dc min, 24V dc nom, 28.8V dc max
Off-state Voltage	5.0V dc max
On-state Current	8 mA max per channel @ 28.8V dc
Input Impedance, Nom	4.8 k $\Omega$
Field Power Dissipation	3.68 W max @ 28.8V dc
Isolation Voltage	50V dc (continuous), reinforced insulation type, tested at 1250V ac for 60 s, I/O to system

### 1790D-OW6 ac/dc Relay Output Block

Attribute	Value
Relay Type	Form A, normally open, single pole, single throw
Output Voltage Range (load dependent)	5...24V dc @ 2.0 A resistive 30V ac @ 2.0 A resistive
Output Current Rating (at rated power)	2.0 A @ 5...24V dc resistive 2.0 A @ 30V dc resistive
Load, Min	100 $\mu$ A, 100 mV dc per point
On-state Voltage Drop, Max	0.5V @ 2.0 A, resistive load, 24V dc
Initial Contact Resistance	30 m $\Omega$
Expected Contact Life	300 kcycles resistive, 100 kcycles inductive
Off-state Leakage, Max	1.5 mA

**1790D-OW6 ac/dc Relay Output Block**

Attribute	Value
Output Delay Time, On to Off, Max	10 ms
Output Delay Time, Off to On, Max	10 ms
Relay Coil Power Dissipation	1.7 W @ 28.8V dc I
Isolation Voltage	50V dc (continuous), reinforced insulation type, tested at 1250V ac for 60 s, I/O to system

**1790D-8BV8V, 1790D-8BV8B dc Input/Output Combination Base Block**

Attribute	Value
Field Power Dissipation	3.22 W @ 28.8V dc
Isolation Voltage	50V dc (continuous), reinforced insulation type, tested at 1250V ac for 60 s, I/O to system

**Input**

Inputs per Module	8 points non-isolated, sinking or sourcing
On-state Voltage	9.6V dc min, 24V dc nom, 28.8V dc max
On-state Current	8 mA max per channel @ 28.8V dc
Off-state Voltage, Max	5V dc
Input Impedance, Nom	4.8 k $\Omega$

**Output**

Outputs per Module	8 points non-isolated, sinking - 1790D-8BV8V 8 points non-isolated, sourcing - 1790D-8BV8B
On-state Voltage, Min	10V dc min
On-state Voltage, Nom	24V dc
On-state Voltage, Max	28.8V dc
On-state Voltage Drop	0.5V dc max

**1790D-8BV8V, 1790D-8BV8B dc Input/Output Combination Base Block**

Attribute	Value
On-state Current, Min	1 mA per channel
Off-state Leakage, Max	0.5 mA
Output Signal Delay, Off to On, Max	0.5 ms
Output Signal Delay, On to Off, Max	1.0 ms
Output Current Rating	0.5 A max per output 4.0 A max per common

**1790D-OV16 and 1790D-OB16 dc Output Base Block**

Attribute	Value
Outputs per Module	16 points non-isolated, sinking: 1790D-OV16 16 points non-isolated, sourcing: 1790D-OB16
On-state Voltage, Max	10V dc min, 24V dc nom, 28.8V dc max
On-state Voltage Drop, Max	0.5V dc max
On-state Current, Min	1.0 mA per channel
Off-state Voltage, Max	28.8V dc
Off-state Leakage, Max	0.5 mA
Output Signal Delay, Off to On	0.5 ms max
Output Signal Delay, On to Off, Max	1.0 ms
Output Current Rating	0.5 A max per output, 4.0 A max per common
Field Power Dissipation	2.76 W @ 28.8V dc
Isolation Voltage	50V dc (continuous), reinforced insulation type, tested at 1250V ac for 60 s, I/O to system

**Environmental Specifications Common To All Base Blocks in This Publication**

<b>Attribute</b>	<b>Value</b>
North American Temp Code	T5
Operating Temperature	IEC 60068-2-1 (Test Ad, Operating Cold), IEC 60068-2-2 (Test Bd, Operating Dry Heat), IEC 60068-2-14 (Test Nb, Operating Thermal Shock) 0...55 °C (32...131 °F)
Storage Temperature	IEC60068-2-1 (Test Ab, Unpackaged Nonoperating Cold) IEC60068-2-2 (Test Bb, Unpackaged Nonoperating Dry Heat) IEC60068-2-14 (Test Na, Unpackaged Nonoperating Thermal Shock) -40...85 °C (-40...185 °F)
Relative Humidity	IEC60068-2-30 (Test Db, Unpackaged Damp Heat) 5...90% noncondensing
Vibration	IEC 60068-2-6 (Test Fc, Operating) 2 g @ 10...500 Hz
Shock, Operating	IEC60068-2-27 (Test Ea, Unpackaged Shock) 10 g
Shock, Nonoperating	IEC60068-2-27 (Test Ea, Unpackaged Shock) 30 g
Emissions	CISPR 11: Group 1, Class A
ESD Immunity	IEC6100-4-2 - 8 kV air discharges
Radiated RF Immunity	IEC 61000-4-3: 10V/m with 1 kHz sine-wave 80%AM from 80...1000 MHz 10V/m with 200 Hz 50% Pulse 100%AM at 900 MHz
EFT/B Immunity	IEC 61000-4-4 ±1 kV at 5 kHz on power ports +2 kV at 5 kHz on signal ports ±2 kV at 5 kHz on communications ports
Surge Transient Immunity	IEC 61000-4-5: ±1 kV line-line (DM) on power ports ±1 kV line-line (DM) on signal ports ±2 kV line-earth (CM) on communications ports
Conducted RF Immunity	IEC61000-4-6 10V rms with 1 kHz sine-wave 80%AM at 150 kHz...80 MHz

**Environmental Specifications Common To All Base Blocks in This Publication**

<b>Attribute</b>	<b>Value</b>
Enclosure Type Rating	None (open-style)
Mounting	DIN rail or panel
Dimension	52 x 104 x 42 mm (2.03 x 4.07 x 1.64 in.)
Weight	0.1 kg (0.3 lb)
Wiring Category <sup>(1)</sup>	2 - on signal ports 2 - on power ports 2 - on communications ports
Wiring	37-pin D-shell connector
<b>DeviceNet</b>	
DeviceNet Power	Supply voltage - 24V dc nom Voltage range - 11...28V dc
DeviceNet Power Dissipation	1.2 W max @ 28.8V dc
Network Length	500 m (1640 ft) max @ 125 Kbps 100 m (328 ft) max @ 500 Kbps
Network Protocol	Slave messaging: <ul style="list-style-type: none"> <li>• Poll command</li> <li>• Bit Strobe command</li> <li>• Cyclic command</li> <li>• COS command</li> </ul>
Indicators	1 red/green module status, 1 red/green network status
Number of Nodes	64 max - rotary switch-type node address setting
Communication Rate	125 Kbps, 250 Kbps, 500 Kbps - auto baud rate selection

<sup>(1)</sup> Use this Conductor Category information for planning conductor routing. Refer to Industrial Automation Wiring and Grounding Guidelines, publication 1770-4.1.

## Certifications

Attribute	Value
Certification <sup>(1)</sup> (when product is marked)	<b>1790D-OV16, 1790D-OB16, 1790D-8BV8V, 1790D-8BV8B, 1790D-16BV0, 1790D-0W6</b> c-UL-us UL Listed Industrial Control Equipment, certified for U.S. and Canada. See UL File E65584. c-UL-us UL Listed for Class I, Division 2, Group A,B,C,D Hazardous Locations, certified for U.S. and Canada. See UL File E194810. European Union 89/336/EEC EMC Directive, compliant with: EN 50082-2; Industrial Immunity EN 61326; Meas./Control/Lab., Industrial Requirements EN 61000-6-2; Industrial Immunity EN 61000-6-4; Industrial Emissions C-Tick Australian Radiocommunications Act, compliant with: AS/NZS CISPR11; Industrial Emissions Open Device Vendors Association (ODVA) conformance tested to DeviceNet specifications

<sup>(1)</sup> See the Product Certification link at [www.ab.com](http://www.ab.com) for Declarations of Conformity, Certificates, and other certification details.

Allen-Bradley, CompactBlock, Rockwell Automation, and RSNetworkx are trademarks of Rockwell Automation, Inc. Trademarks not belonging to Rockwell Automation are property of their respective companies

[www.rockwellautomation.com](http://www.rockwellautomation.com)

### Power, Control and Information Solutions Headquarters

Americas: Rockwell Automation, 1201 South Second Street, Milwaukee, WI 53204-2496 USA, Tel: (1) 414.382.2000, Fax: (1) 414.382.4444  
Europe/Middle East/Africa: Rockwell Automation, Vorstaan/Boulevard du Souverain 36, 1170 Brussels, Belgium, Tel: (32) 2 663 0600, Fax: (32) 2 663 0640  
Asia Pacific: Rockwell Automation, Level 14, Core F, Cyberport 3, 100 Cyberport Road, Hong Kong, Tel: (852) 2887 4788, Fax: (852) 2508 1846

Publication 1790-IN007C-EN-P - May 2006

PN 953014-39

Supersedes Publication 1790-IN007B-EN-P - April 2003

Copyright © 2006 Rockwell Automation, Inc. All rights reserved. Printed in the U.S.A.