



Sub I/O Scanner Module

(Cat. No. 1771-SN, Series A, Revision D)

Installation Instructions

To The Installer

This document gives you information on:

- compatible processors
- compatible adapters
- how to install the 1771-SN Scanner Module
- how to connect the remote I/O link
- how to set the sub I/O scanner switches
- how to set switches on remote devices
- how to program the 1771-SN Scanner Module
- the ladder program for remote I/O
- update time
- how to troubleshoot your module
- guard against electrostatic discharge
- system configuration
- specifications

Compatible Processors

Use the 1771-SN Scanner Module with any processor with block-transfer capability.

Compatible Adapters

The 1771-SN Scanner Module communicates only with adapters with discrete transfer capability.

The module does not support complementary I/O.

Guard Against Electrostatic Discharge

Under some conditions, electrostatic discharge can degrade performance or damage the module. Observe the following precautions to guard against electrostatic damage.

- Touch a grounded object to discharge yourself of static electricity before handling the module.
- Do not touch the backplane connector or connector pins.
- When not in use, keep the module in its static-shield bag.

Install the 1771-SN Scanner Module

Before you install the module into the I/O chassis:

1. Turn off power to the chassis.



ATTENTION: Remove power from the 1771-I/O chassis backplane before removing or installing an I/O Module.

- Failure to remove power from the backplane could cause module damage, degradation of performance, or injury.
 - Failure to remove power from the backplane could cause injury or equipment damage due to possible unexpected operation.
2. Reserve an I/O slot for the module by placing keying bands on the backplane connector. Position keying bands between the following numbers labeled on the backplane adjacent to the upper backplane connector:
 - between 2 and 4
 - between 24 and 26

The keying bands mate with corresponding slots in the module connector.

Connect the Remote I/O Link

Connect your module in a daisy-chain configuration.

Connect to the Module Connector

Connect your cable (1770-CD or equivalent, refer to the Approved Cable Vendor List, pub. no. ICCG-2.2) to the module connector at the bottom front of the module (Figure 1). Use either of the two sets of terminals. They connect in parallel inside of the module.

Figure 1
Connecting your module to a daisy-chain cable

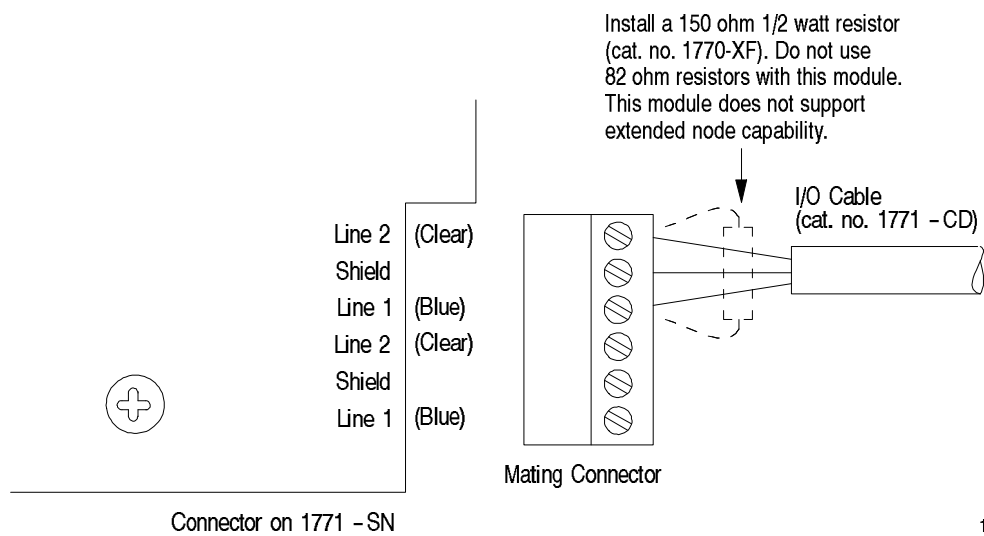

Connect to a Daisy-Chain Hook-up

When using a daisy-chain hook-up (Figure 2), connect each I/O chassis to the remote I/O channel. This cable length should not exceed:

- 10,000 cable feet for 57.6k bits per second.
- 5,000 cable feet for 115.2k bits per second.

Install a 150-ohm 1/2-Watt terminator resistor (1770-XT or equivalent) (Figure 1) between the blue and clear wires at both ends of the communication link.

Figure 2
Example Daisy-Chain Hook-Up

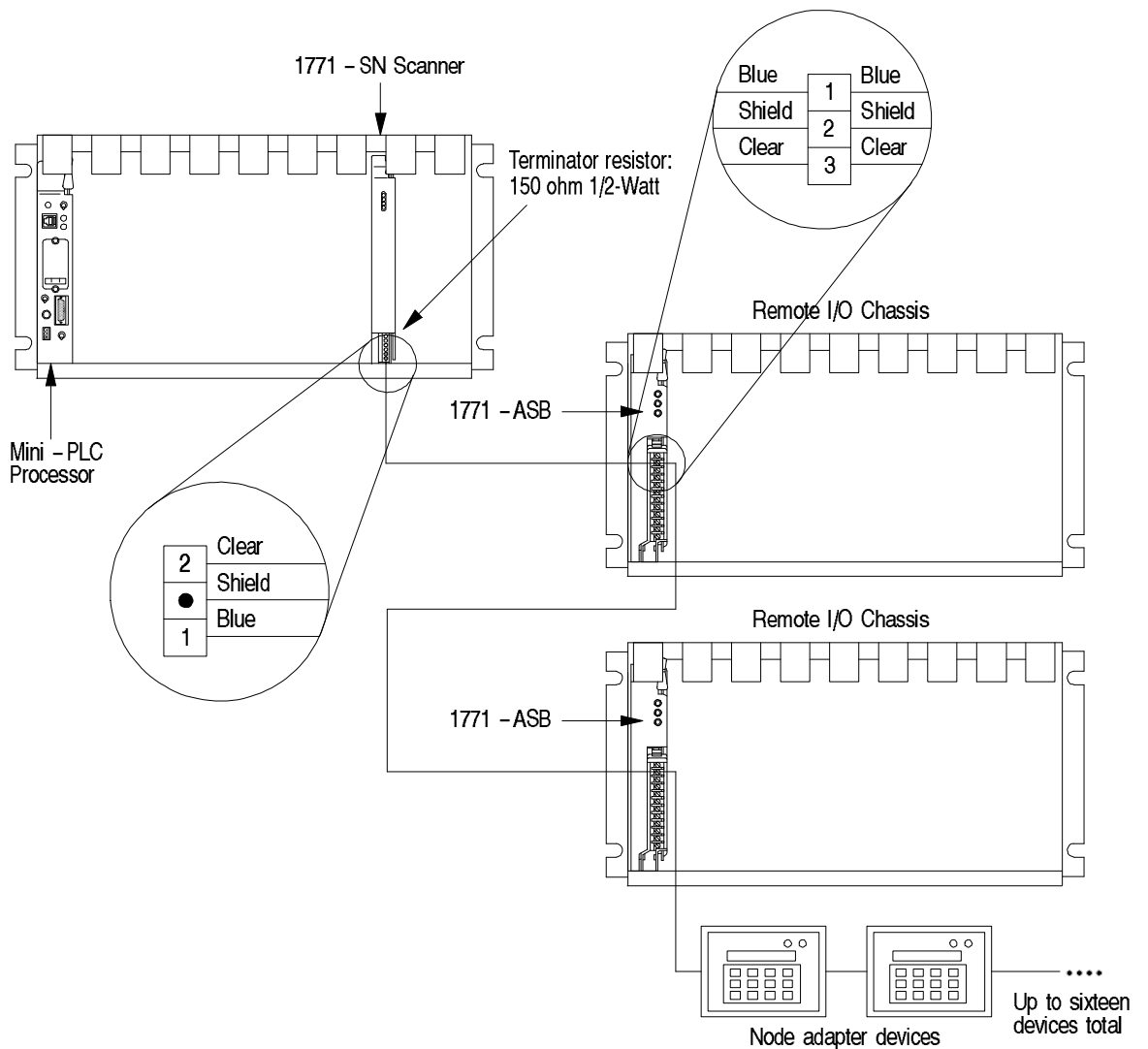

Setting Sub I/O Scanner Switches

Select module options by setting switches in switch bank 0 (Table 1) and switch bank 1 (Table 2) in the cutout located on the left side of the module. Each switch bank has eight switches. Set each switch to the ON (closed) position by pressing the switch toward the numbers on the switch or to the OFF (open) position by pressing the switch toward “open”.

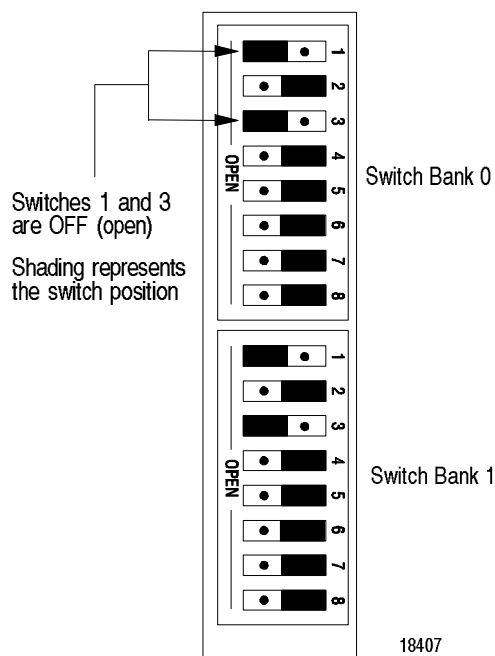

Table 1
Switch Bank 0

To Set	To	Set Switch	To
Communication Rate ¹	57.6k bits/s	1	ON (closed) (up to 10,000 feet)
	115.2k bits/s	1	OFF (open) (up to 5,000 feet)
Remote Outputs ² (for local chassis fault)	off	2	ON (closed)
	last state	2	OFF (open)
Fault Control	independent	3	ON (closed)
	dependent	3	OFF (open)
Fault Table ³	enable	4	OFF (open)
	disable	4	ON (closed)
Unused Switches	—	5, 6, 7, 8	OFF (open)

¹ Set the same communication rate for the 1771-SN Scanner and all adapter devices linked to the 1771-SN Scanner on the remote I/O link.

² Controls output states of non-faulted remote I/O chassis when the local processor in the chassis containing the Scanner detects a fault. A switch selection of each remote chassis controls the output states of that chassis when the adapter in that chassis detects a fault.

Independent fault control

Lost communications with one I/O chassis does not affect operation of the other I/O chassis if each chassis has a different assigned rack number.

If both I/O chassis have the same rack number, you must set the faulted I/O search switch on the ON (closed) position to prevent a fault in one I/O chassis from affecting the other.

The 1771-SN Scanner clears the fault bit automatically after you correct the fault. You must recycle power to the Scanner to clear the fault counter.

Dependent fault control

Lost communication with one I/O chassis causes the outputs of the other chassis to reset or remain in their last state according to how you set the last state switch on each chassis.

To clear a dependent fault, you must correct the fault and re-enable the backplane by switching the processor to program mode and back to the run mode.

³ When you enable this function, the module generates a fault table in the seventh and eighth words of the block-transfer read file (Figure 7). The module sets a fault bit to report a fault in each possible quarter rack (two I/O groups) on the serial link. The read file also contains discrete input data from the remote I/O chassis.

Installation Instructions
Sub I/O Scanner Module
Cat. No. 1771-SN

Table 2
Switch Bank 1

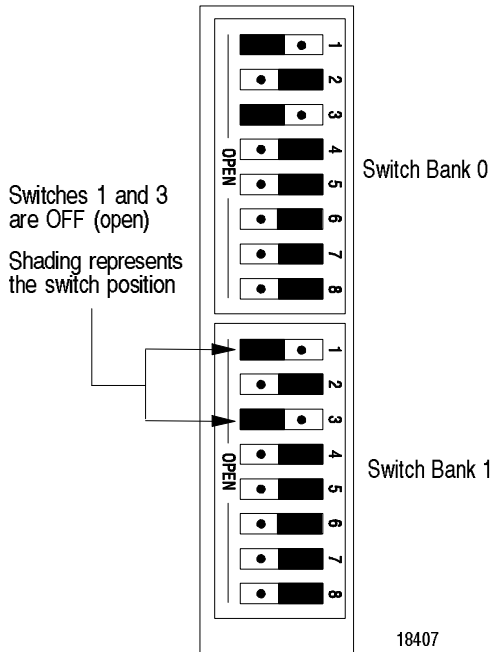

To Set	To	Set Switch	To
Remote I/O Rack Number ¹	enable scanning of corresponding I/O rack	1 through 7	ON (closed)
	inhibit scanning of corresponding I/O rack	1 through 7	OFF (open)
Faulted I/O Search ²	enable	8	ON (closed)
	disable	8	OFF (open)

¹ Set switch 1, ON to enable scanning of rack 1; switch 2 for rack 2; switch 3 for rack 3; etc. Selecting I/O rack numbers greater than two increases block-transfer file lengths and I/O update times.
² We recommend that you assign a separate remote I/O rack number to each I/O chassis, however;

If	And	And	Then
Both I/O chassis have the same assigned rack number	you enable Faulted I/O Search	you select independent fault control	a communication loss with one I/O chassis does not affect the other chassis
Both I/O chassis have the same assigned rack number	you disable Faulted I/O Search	you select independent fault control	a communication loss with one I/O chassis causes the outputs of both chassis to be reset or left at last state

Setting Switches on Remote Devices

Use PLC-2 compatible switch settings for all remote devices controlled by the 1771-SN Scanner.

Programming the 1771-SN Scanner

Your ladder program instructions must include block-transfer read and write instructions (and a file to file move instruction for PLC-2 Processors only) (Figure 3). You can calculate block length using the equation:

$$8 + (8 \times \text{highest rack number})$$

If you select the default block length 00 for the BTR/BTW to the SN module, it will read and write sixteen words or enough data for rack 1. If you have a higher rack number, use the formula above to determine the BTR/BTW length.

Following are example block-transfer programs for PLC-2, PLC-3, and PLC-5 Processors.

Figure 3
Block-Transfer Programming Example for a PLC-2 Processor

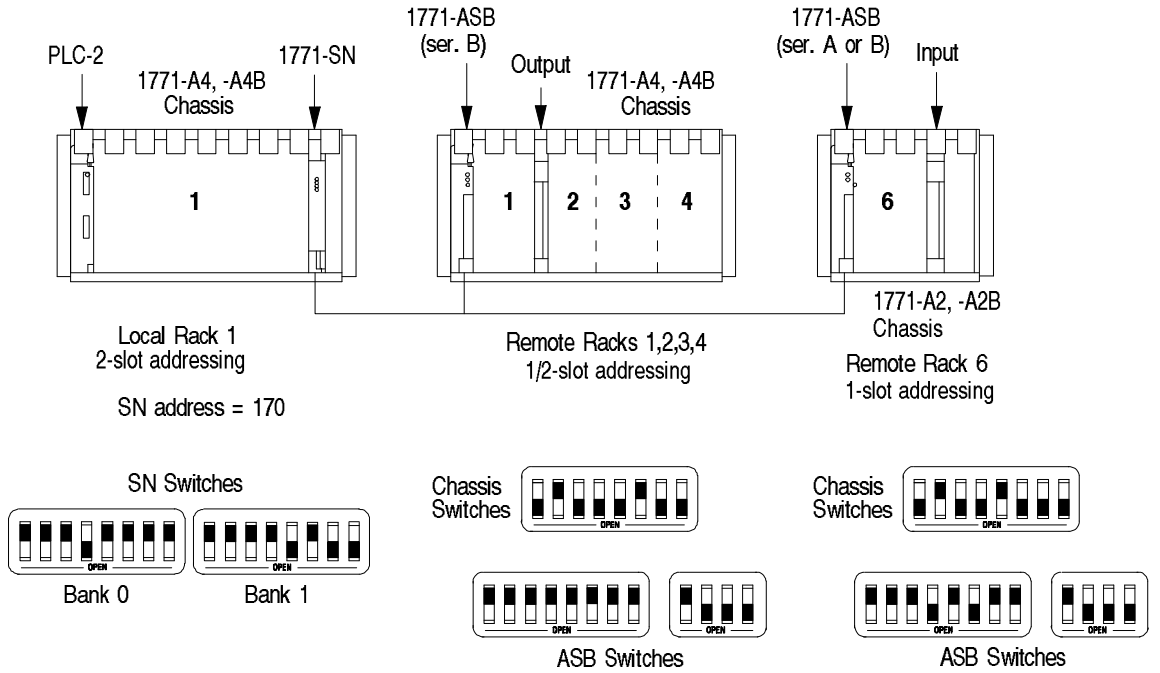

Figure 4
Block-Transfer Programming Example for a PLC-3 Processor

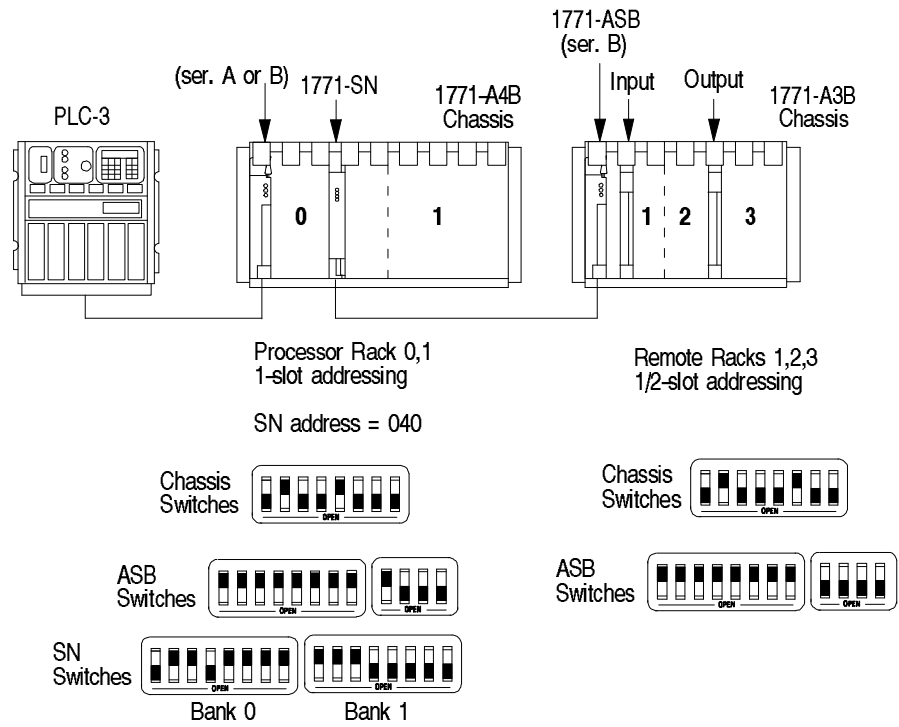
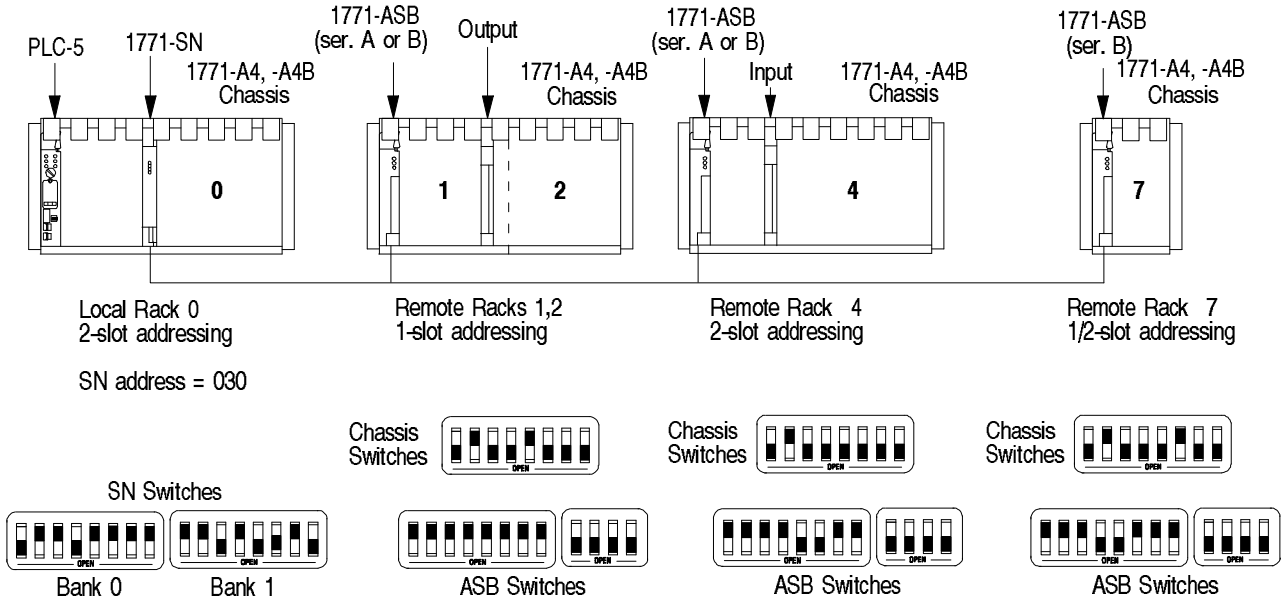
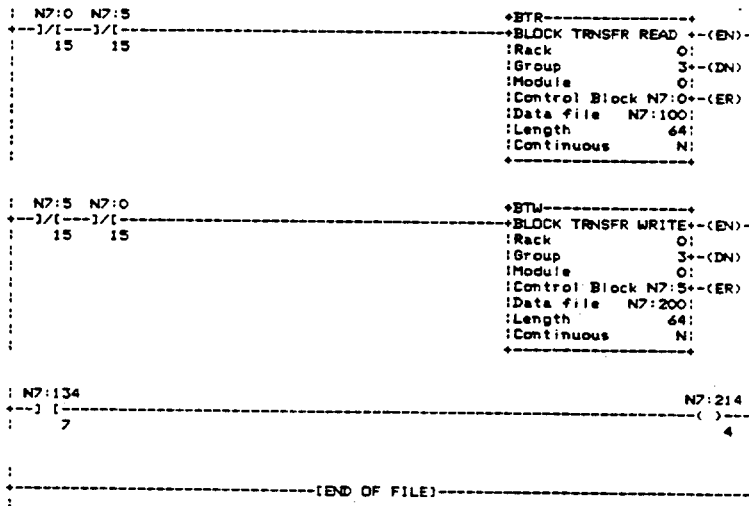

Figure 5
Block-Transfer Programming Example for a PLC-5 Processor



18177

Ladder Logic:



Comments:

SN rack addr: 0
 SN group addr: 3
 SN module addr: 0
 Control block: user designated (5 words)
 Data file: user designated at addr: 100
 Length = 8+(8x7) = 64
 Remote I/O rung:
 Input: Rack #4, I/O group #2, bit #7
 Output: Rack #1, I/O group #6, bit #4

Installation Instructions
 Sub I/O Scanner Module
 Cat. No. 1771-SN

Figure 6
 Input and output data files for transfer to the processor

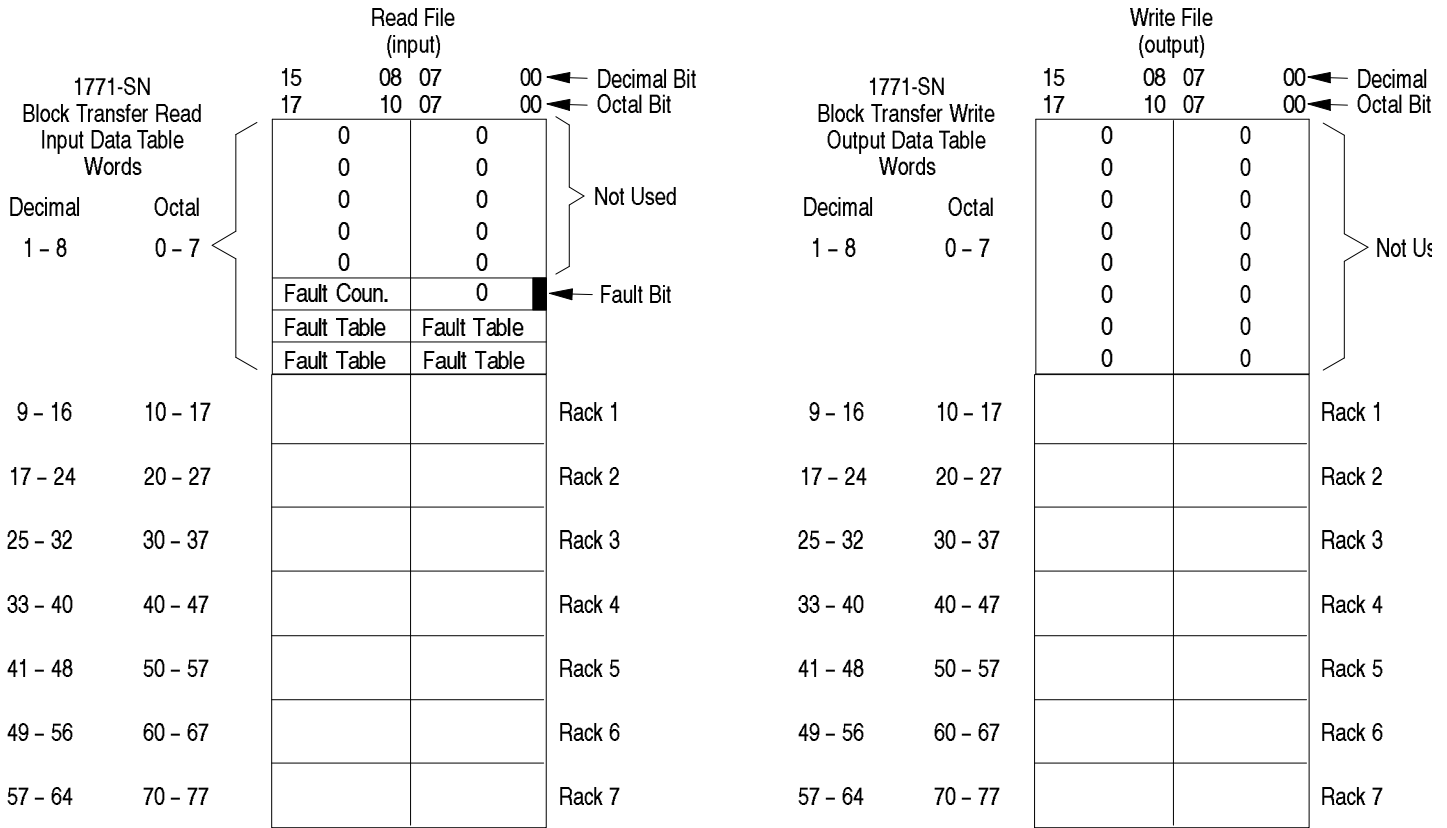
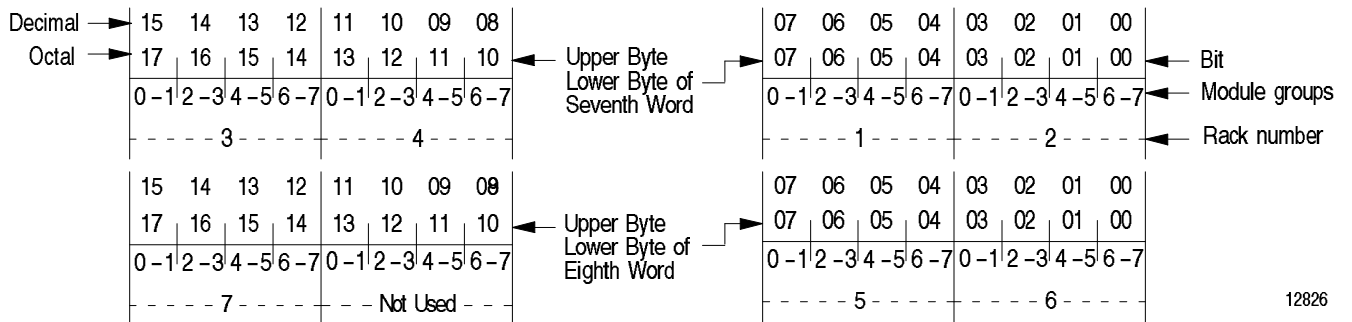

Figure 7
 Fault Table: Each bit identifies a quarter rack



Status Word

The upper byte of the sixth decimal word of the block-transfer read contains a retentive count of the number of serial communication faults detected by the 1771-SN Scanner. This counter resets by cycling power to the SN Scanner. The 1771-SN Scanner sets bit 0 of this word every time it detects a fault, and resets it when you correct the fault.

Fault Table

If a rack fault occurs, the Scanner sets a bit in the seventh and/or eighth decimal words identifying the quarter chassis in which a fault occurred (Figure 7).

Important: All addresses in the following sections refer to the PLC-2 Programming Example (Figure 3).

Storage of Read File (PLC-2 applications)

For PLC-2 applications you should move the block-transfer read data file to a storage location using a file to file move instruction. Set the file length of the file move instruction to $8 + (8 \times \text{the highest rack number})$ words.

Input Data (Block-Transfer Read)

Input data from the remote I/O racks connected to the 1771-SN Scanner, transfers to the PLC through the block-transfer read in the ladder logic. Eight words are required for I/O data from each full remote I/O chassis. Use the following equation to determine the total number of words required (file length):

$$8 + (8 \times \text{highest rack number}) = \text{file length}$$

Important: The first 8 words (0 through 7 octal) are reserved for fault indication and do not contain input data.

The ninth word (10 octal) corresponds to module group 0 of rack number 1. The most significant byte is slot 1. The least significant byte is slot 0.

The 17th word (20 octal) corresponds to module group 0 of rack number 2, etc.

Output Data (Block-Transfer Write)

Output data to the remote I/O racks connected to the 1771-SN Scanner, transfers from the PLC through the block-transfer write in the ladder logic.

Important: The first 8 words (0 through 7 octal) are reserved.

The ninth word (10 octal) corresponds to module group 0 of rack number 1. The most significant byte is slot 1. The least significant byte is slot 0.

The 17th word (20 octal) corresponds to module group 0 of rack number 2, etc.

Block-Transfer Write File

Assign a block-transfer write (BTW) file for sending output data through the Scanner to remote I/O chassis. Output data for rack 1 uses words 10 through 17 octal. Rack 2 uses words 20 through 27 octal. Choose your own method for moving output data into the BTW file.

Module Address

Location in the chassis and addressing scheme (1, 2, or 1/2 slot addressing) determine the 1771-SN Scanner's address.

Ladder Program for Remote I/O

Remote I/O addresses correspond with the addresses in the block-transfer read (input) and block-transfer write (output) files. For example, you would monitor an input in rack 6, module group 5, terminal 2, and energize an output in rack 2, module group 1, terminal 6 as follows based on example block-transfer files (Figure 3) at 300 (read) and 400 (write).

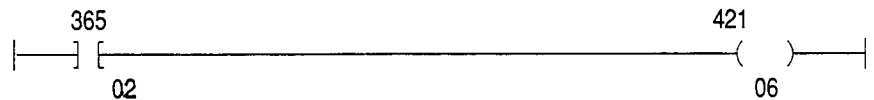

Local Processor Scan

When you use a Sub I/O Scanner, the time period for the processor to scan the program and local I/O includes a block-transfer write to the Scanner or a block-transfer read from the Scanner. The total time for the block-transfer is:

$$\text{Block-transfer time} = 0.1\text{ms} + 0.16\text{ms} \times \text{number of words}$$

For example, each block-transfer of 64 words takes 10ms.

Remote I/O Update

The time required for a remote output to change after receiving a changed input is the sum of:

- the input circuit delay time
- a remote I/O scan (7ms per chassis) to read from the input module
- the through-put time of the scanner (15ms)
- 3 local processor scans: block-transfer read, perform ladder logic and block-transfer write
- the through-put time of the scanner (15ms)
- a remote I/O scan (7ms per chassis) to write to the output module

For example, with 2 remote I/O chassis, a local processor scan time (including block-transfer for the Scanner) of 40ms and an input circuit delay time of 24ms, the remote I/O update time is:

Input Circuit delay time	24ms
1771-SN scan (7ms/chassis x 2 chassis)	14ms
1771-SN throughput	15ms
Block-transfer read time	40ms
Program (read)	20ms
Program (write)	20ms
Block-transfer write time	40ms
1771-SN through put	15ms
1771-SN scan (7ms/chassis x 2 chassis)	14ms
Total	202ms

Troubleshoot Your Module

When troubleshooting your module, check the following in the order given to determine the cause of the fault.

- LEDs on the SN Scanner
- block-transfer rungs in the ladder program of your processor
- status bits in the status word read by the processor

LED Display for Normal and Fault Conditions

Under normal and fault conditions, the LEDs light as follows:

	ON	BLINKING	OFF
Power (PWR)	Normal Operation	Not Used	No Power-Check backplane power supply
Serial Communication (SER COM) ¹	Normal Operation-Communicating with all remote racks	Communicating with some remote racks or partial communications with all racks	No Communications Check the following: cable connections in the remote I/O link power to the I/O chassis transmission rate setting of the 1771-SN Scanner is the same as the 1771-AS or ASB switch settings of remote I/O chassis correspond to the remote rack numbers that you set for the 1771-SN Scanner
Backplane Communication (BPLN COM) ¹	Processor and SN doing block transfers at a rate greater than 1 every 1/2 second	Processor and SN doing block transfers at a rate less than 1 every 1/2 second	No block transfers being done Refer to "Possible Causes of Block-Transfer Errors" below
Module Fault (SN FLT)	SN hardware fault- Cycle power to the I/O chassis containing the 1771-SN Replace the module if the LED remains lit after restoring power	Not Used	Normal Operation

¹ The Serial Communication and Backplane Communication LEDs blink at power-up if you do not select a rack number for the 1771-SN using switch bank 1. To operate the module, you must assign a rack number.

All LEDs light briefly at power-up for a lamp test.

Possible Causes of Block-Transfer Errors

Observe block-transfer rungs in the ladder diagram of the local processor. You have a block-transfer error when you observe that enable and done bits of block-transfer instructions either do not intensify or remain intensified. They should alternately turn on (intensify) and turn off.

Following are possible causes of block-transfer errors:

- The 1771-SN's location; rack, group and slot in the local I/O chassis does not match the rack, group and slot of block-transfer instructions in the ladder diagram.
- When using PLC-2 unconditional block-transfers the block lengths of block-transfer read and write instructions are not equal. If different, do not enable block-transfer read and block-transfer write instructions in the same scan.
- Conditioning instructions in block-transfer rungs allow the rungs to turn on and off at the wrong time.

System Configuration

You can connect up to 16 remote I/O chassis to the Scanner using a daisy-chain cable configuration (Figure 2). You can use smaller I/O chassis but no more than seven full I/O racks (896 I/O per system). The Scanner cannot perform block-transfers with remote I/O adapters. Table 3 represents the configurations for maximum discrete I/O that you can use with the Scanner.

Table 3
System configurations for maximum discrete I/O

Type of Addressing	I/O Adapter Qty-Type	I/O Chassis Qty-Type	Number of Discrete I/O
2 slot	7 1771-AS,-ASB	7 1771-A4,-A4B	up to 896
1 slot	4 1771-ASB	4 1771-A4B	up to 896
	7 1771-ASB	7 1771-A2B	up to 896
1/2 slot	4 1771-ASB	4 1771-A2B	up to 896

Refer to Chapter 4, "Assigning Addressing Modes, Racks and Groups" in the 1785 PLC-5 Family Programmable Controllers Design Manual, publication 1785-6.2.1, for information on 1/2, 1 and 2 slot addressing.

Specifications

1771-SN Sub I/O Scanner Module	
Module Location	1771-A1B thru -A4B or later I/O chassis and 1771-AM1 and -AM2 I/O chassis
Data Transmission Rate	10,000 cable-feet at 57.6k bits/s 5,000 cable-feet at 115.2k bits/s
Interconnect Cable	1770-CD or equivalent (refer to the Approved Cable Vendor List, pub. no. ICCG-2.2)
Backplane Current	1.2A
Power Dissipation	7W maximum @ 1.2A
Thermal Dissipation	24 BTU maximum @ 1.2A
Keying	Between 2 and 4 Between 24 and 26
Environmental Conditions: Operating Temperature Storage Temperature Relative Humidity	0° to 60°C (32° to 140°F) -40° to 85°C (-40° to 185°F) 5% to 95% (without condensation)
System	Supports PLC-2 rack addresses 1 thru 7 Supports up to 16 total adapters Does not support complementary I/O
Part Numbers and Catalog Numbers	Daisy-Chain configurations Phoenix Connector (6-pin) (Allen-Bradley part number 940611-01) 1771-ASB Remote I/O Adapter termination resistor (Cat. No. 1770-XT) Dropline Configurations T-Connector (Cat. No. 1770-XG), Allen-Bradley part number 966308-01) Station Connector (Cat. No. 1770-SC), (Allen-Bradley part number 966080-01) Terminator Set (Cat. No. 1770-XF), (Allen-Bradley part number 966307-01)

PLC, RediPANEL, PanelView, PLC-2/10, PLC-2/12, PLC-2/15 and Dataliner are trademarks of Allen-Bradley Company, Inc.



Allen-Bradley, a Rockwell Automation Business, has been helping its customers improve productivity and quality for more than 90 years. We design, manufacture and support a broad range of automation products worldwide. They include logic processors, power and motion control devices, operator interfaces, sensors and a variety of software. Rockwell is one of the worlds leading technology companies.



Worldwide representation.

Argentina • Australia • Austria • Bahrain • Belgium • Brazil • Bulgaria • Canada • Chile • China, PRC • Colombia • Costa Rica • Croatia • Cyprus • Czech Republic • Denmark • Ecuador • Egypt • El Salvador • Finland • France • Germany • Greece • Guatemala • Honduras • Hong Kong • Hungary • Iceland • India • Indonesia • Ireland • Israel • Italy • Jamaica • Japan • Jordan • Korea • Kuwait • Lebanon • Malaysia • Mexico • Netherlands • New Zealand • Norway • Pakistan • Peru • Philippines • Poland • Portugal • Puerto Rico • Qatar • Romania • Russia-CIS • Saudi Arabia • Singapore • Slovakia • Slovenia • South Africa, Republic • Spain • Sweden • Switzerland • Taiwan • Thailand • Turkey • United Arab Emirates • United Kingdom • United States • Uruguay • Venezuela • Yugoslavia

Allen-Bradley Headquarters, 1201 South Second Street, Milwaukee, WI 53204 USA, Tel: (1) 414 382-2000 Fax: (1) 414 382-4444