

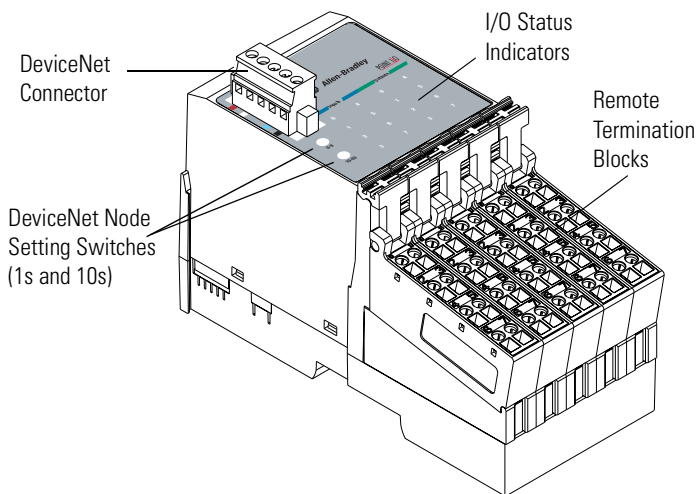

Installation Instructions

POINTBlock ac 8 Input/8 Relay Output Module

(Cat. No. 1734D-IA8XOW8, -IA8XOW8S)



This 1734D input/output module is a DIN-rail mounted device with an integrated DeviceNet communication interface, 8 ac inputs and 8 relay outputs, removable terminations, and a PointBus expansion port. The expansion port allows you to add up to a maximum of 12 additional POINT I/O modules.

The module includes a non-isolated DeviceNet communication interface. The 24V dc from the DeviceNet connection powers a non-isolated dc/dc converter that generates +5V dc which powers the POINTBlock electronics and connects to the PointBus port to power the expansion I/O electronics.

The 1734-IA8XOW8 uses cage-clamp terminations, and the 1734-IA8XOW8S uses spring-clamp terminations.

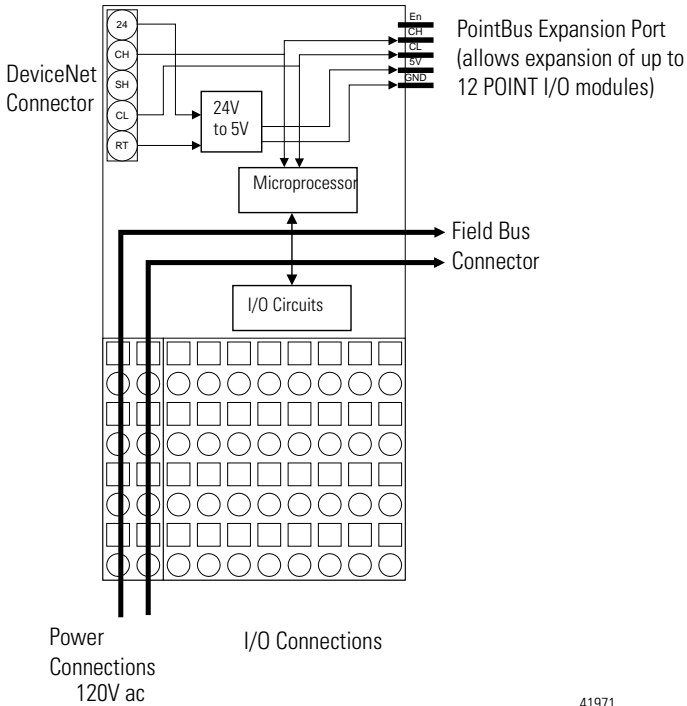

41971

ATTENTION



Whatever field power you supply is connected to the internal field-power bus. **For example, if 120V ac is applied to the power connections, there will be 120V ac applied to the modules through the internal field-power bus.**

POINT I/O modules to the right of the module will also have that internal power bus voltage applied, unless you use a 1734-FPD to interrupt and change the field power-bus voltage.

ATTENTION



POINTBlock is designed to be grounded through the DIN rail to chassis ground. To assure proper grounding of POINTBlock and POINT I/O adapters and terminal bases to chassis ground, the recommended DIN rail material is zinc-plated, yellow-chromated steel. Mount POINTBlock, POINT I/O adapters and terminal bases only to zinc-plated, yellow-chromated steel.

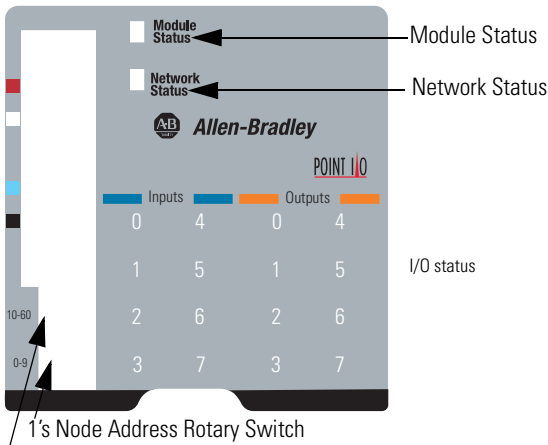

10's Node Address Rotary Switch

42004

To set the node address, set the combination of 1's and 10's to correspond to the required address. (For example, for 61, set the 10's switch to 6 and the 1's switch to 1.)

Wiring

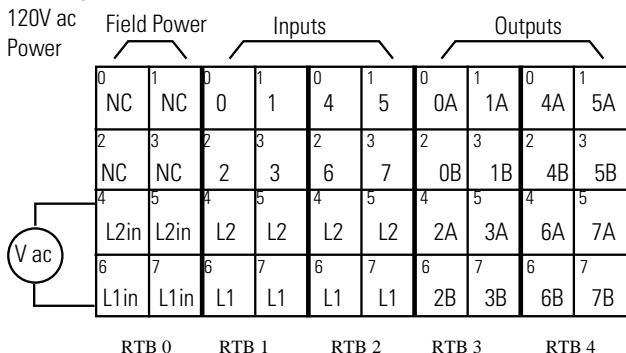

This supply will be connected to the internal power bus.

NC = No connection

L2/N = AC Return/Neutral L1 = AC Power

41976

Input Wiring

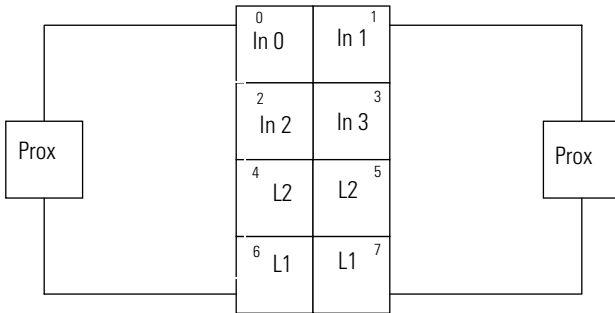

L1 = 120V ac
L2 = Return

41967ac

Channel	Input Terminal	Return	Voltage
Remote Termination Block 1			
0	0	4	6
1	1	5	7
2	2	4	6
3	3	5	7
Remote Termination Block 2			
4	0	4	6
5	1	5	7
6	2	4	6
7	3	5	7

120V ac is supplied through the internal power bus.

Note: When connecting more than 1 wire in a termination point, make sure that both wires are the same gauge and type.

Output Wiring

Load powered by External Power

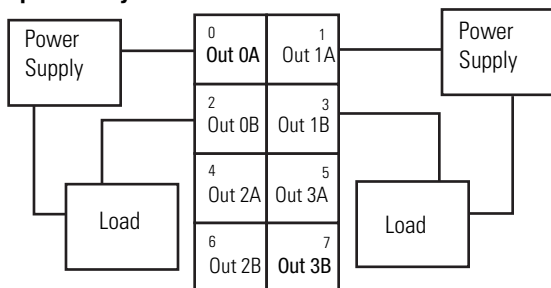

Out = Output channel relay contacts

L1 = 120V ac L2 = Return

Channel	Output	Common	Supply
Remote Termination Block 3			
0A	0		
0B	2		
1A	1		
1B	3		
2A	4		
2B	6		
3A	5		
3B	7		
Remote Termination Block 4			
4A	0		
4B	2		
5A	1		
5B	3		
6A	4		
6B	6		
7A	5		
7B	7		

Supply voltage is 120V ac.



12/24V dc power for the module is provided by the internal power bus.

Note: When connecting more than 1 wire in a termination point, make sure that both wires are the same gauge and type.

DeviceNet Connector Wiring

DeviceNet connection	Red	+V
	White	CAN - High
	Bare	Shield
	Blue	CAN - Low
	Black	-V

42132

<p>The following information applies when operating this equipment in hazardous locations:</p>	<p>Informations sur l'utilisation de cet équipement en environnements dangereux :</p>
<p>Products marked "CL I, DIV 2, GP A, B, C, D" are suitable for use in Class I Division 2 Groups A, B, C, D, Hazardous Locations and nonhazardous locations only. Each product is supplied with markings on the rating nameplate indicating the hazardous location temperature code. When combining products within a system, the most adverse temperature code (lowest "T" number) may be used to help determine the overall temperature code of the system. Combinations of equipment in your system are subject to investigation by the local Authority Having Jurisdiction at the time of installation.</p>	<p>Les produits marqués "CL I, DIV 2, GP A, B, C, D" ne conviennent qu'à une utilisation en environnements de Classe I Division 2 Groupes A, B, C, D dangereux et non dangereux. Chaque produit est livré avec des marquages sur sa plaque d'identification qui indiquent le code de température pour les environnements dangereux. Lorsque plusieurs produits sont combinés dans un système, le code de température le plus défavorable (code de température le plus faible) peut être utilisé pour déterminer le code de température global du système. Les combinaisons d'équipements dans le système sont sujettes à inspection par les autorités locales qualifiées au moment de l'installation.</p>
<p>WARNING</p> 	<p>EXPLOSION HAZARD</p> <ul style="list-style-type: none"> • Do not disconnect equipment unless power has been removed or the area is known to be nonhazardous. • Do not disconnect connections to this equipment unless power has been removed or the area is known to be nonhazardous. Secure any external connections that mate to this equipment by using screws, sliding latches, threaded connectors, or other means provided with this product. • Substitution of components may impair suitability for Class I, Division 2. • If this product contains batteries, they must only be changed in an area known to be nonhazardous.
<p>AVERTISSEMENT</p> 	<p>RISQUE D'EXPLOSION</p> <ul style="list-style-type: none"> • Couper le courant ou s'assurer que l'environnement est classé non dangereux avant de débrancher l'équipement. • Couper le courant ou s'assurer que l'environnement est classé non dangereux avant de débrancher les connecteurs. Fixer tous les connecteurs externes reliés à cet équipement à l'aide de vis, loquets coulissants, connecteurs filetés ou autres moyens fournis avec ce produit. • La substitution de composants peut rendre cet équipement inadapté à une utilisation en environnement de Classe I, Division 2. • S'assurer que l'environnement est classé non dangereux avant de changer les piles.

Specifications - 1734D-IA8XOW8, -IA8XOW8S**Input Specifications**

ON-State Voltage	65V ac min
ON-State Current	5.0mA min
OFF-State Voltage	43V ac max
OFF-State Current	2.5mA max
Nominal Input Impedance	17.0k Ω
Input Delay Time OFF to ON ON to OFF	20ms hardware + (0-65ms selectable) 20ms hardware + (0-65ms selectable)
External AC Power Supply Voltage	120V ac, 60Hz nominal
External AC Power Supply Voltage Range	85-132V ac, 47-63Hz

Output Specifications

Relay Type	Form A, normally open (N.O.) Single Pole, Single Throw (SPST)
Output Voltage Range (load dependent)	5-30V dc @ 2.0A resistive 48V dc @ 0.5A resistive 125V dc @ 0.25A resistive 125V ac @ 2.0A resistive 240V ac @ 2.0A resistive
Output Current Rating (at rated power)	Resistive 2A @ 5-30V dc 0.5A @ 48V dc 0.25A @ 125V dc 2A @ 125V ac 2A @ 240V ac Inductive 2.0A steady state @ 5-30V dc, L/R = 7ms 0.5A steady state @ 48V dc, L/R = 7ms 0.25A steady state @ 125V dc, L/R = 7ms 2.0A steady state, 15A make @ 125V ac, PF = $\cos \theta = 0.4$ 2.0A steady state, 15A make @ 240V ac, PF = $\cos \theta = 0.4$

10 POINTBlock ac 8 Input/8 Relay Output Module

Power Rating	250W max for 125V ac resistive loads 480W max for 240V ac resistive loads 60W max for 28.8V dc resistive loads 24W max for 48V dc resistive loads 31W max for 125V dc resistive loads 250VA max for 125V ac inductive loads 480VA max for 240V ac inductive loads 60VA max for 28.8V dc inductive loads 24VA max for 48V dc inductive loads 31VA max for 125V dc inductive loads
Minimum Load	10mA per point
Initial Contact Res.	30m Ω
Switching Frequency	1 operation/3s at rated load
Bounce Time	1.2ms average
Expected Contact Life	300K cycles resistive; 100K cycles inductive
Maximum OFF-State Leakage	1.5mA max
Output Delay Time	10ms max ON/OFF
General Specifications	
Pointbus Output Current	1A max @ 5V ac output
DeviceNet Current	95mA maximum for POINTBlock 350mA for maximum with expansion of 12 POINT I/O modules
Number of POINT I/O Expansion Modules	12 maximum added at expansion port
Isolation Voltage	1250Vrms or 2121V dc for 1s between user power and DeviceNet
Indicators	1 red/ green module status indicator 1 red/green network status indicator 16 I/O status indicators (8 input/8 output)
Power Dissipation	2.0W maximum @ 24V dc
Power Consumption	8.2W maximum @ 24V dc
Field Power Bus Supply Voltage Voltage Range Supply Current	24V dc nominal 10-28.8V dc 10A max
Dimensions Inches (Millimeters)	3.00H x 2.36W x 5.25L (76.2 Hx 60.0W x 133.4L)

Environmental Conditions	
Operational Temperature	-20 to +55°C (-4 to +131°F)
Storage Temperature	-40 to 85°C (-40 to 185°F)
Relative Humidity	5 to 95% noncondensing
Shock	30g peak acceleration, 11(±1)ms pulse width
Operating	
Non-operating	50g peak acceleration, 11(±1)ms pulse width
Vibration	Tested 5g @ 10-500Hz per IEC 68-2-6
Conductors Wire Size	14 AWG (2.5mm ²) - 22 AWG (0.25mm ²) solid or stranded max
Category	3/64 inch (1.2mm) insulation max 2 ¹
Terminal Base Screw Torque	5-7 pound-inches (0.5-0.6 Nm)
Field Wiring Terminations	
DeviceNet	1 - Black Wire -V 2 - Blue Wire CAN Low 3 - Bare Wire Drain 4 - White Wire CAN High 5 - Red Wire +V
Field Power Supply	0 - No Connection 1 - No Connection 2 - No Connection 3 - No Connection 4 - AC return 5 - AC return 6 - AC power 7 - AC power
Mass	13.87 oz/393.41 grams
Agency Certification (when product is marked)	<ul style="list-style-type: none"> • C-UL Listed • C-UL Class I, Division 2 Groups A, B, C and D certified • UL listed • CE marked for all applicable directives • C-Tick marked for all applicable acts
<p>¹ Use this conductor category information for planning conductor routing. Refer to publication 1770-4.1, "Industrial Automation Wiring and Grounding Guidelines for Noise Immunity."</p>	

www.rockwellautomation.com

Power, Control and Information Solutions Headquarters

Americas: Rockwell Automation, 1201 South Second Street, Milwaukee, WI 53204-2496 USA, Tel: (1) 414.382.2000, Fax: (1) 414.382.4444

Europe/Middle East/Africa: Rockwell Automation, Vorstlaan/Boulevard du Souverain 36, 1170 Brussels, Belgium, Tel: (32) 2 663 0600, Fax: (32) 2 663 0640

Asia Pacific: Rockwell Automation, Level 14, Core F, Cyberport 3, 100 Cyberport Road, Hong Kong, Tel: (852) 2887 4788, Fax: (852) 2508 1846

Publication 1734-5.23 - February 2000

PN 957236-90

© 2000 Rockwell International Corporation. Printed in USA