

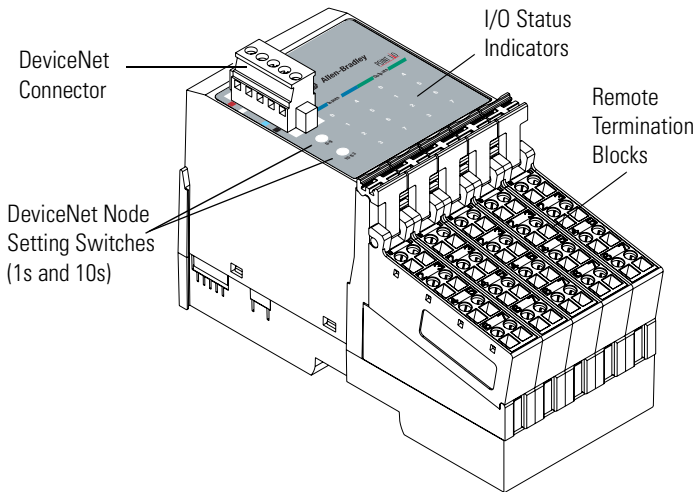

Installation Instructions

POINTBlock dc 8 Input/8 Output Module

(Cat. No. 1734D-IB8XOB8E and -IB8XOB8ES)



This 1734D input/output module is a DIN-rail mounted device with an integrated DeviceNet communication interface, 8 inputs and 8 outputs, removable terminations, and a PointBus expansion port. The expansion port allows you to add up to a maximum of 12 additional POINT I/O modules.

The module includes a non-isolated DeviceNet communication interface. The 24V dc from the DeviceNet connection powers a non-isolated dc/dc converter that generates +5V dc which powers the POINTBlock electronics and connects to the PointBus port to power the expansion I/O electronics.

The 1734D-IB8XOB8E uses cage-clamp terminations, and the 1734D-IB8XOB8ES uses spring-clamp terminations.

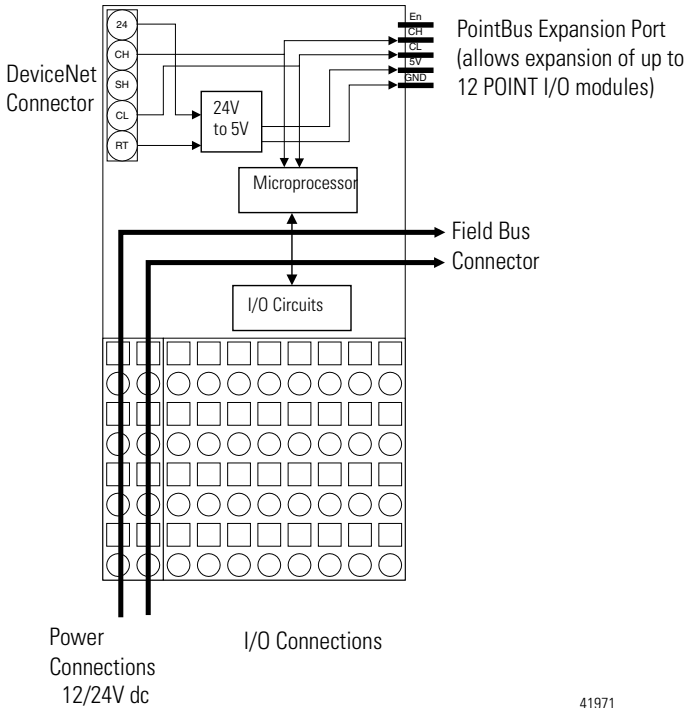

41971

ATTENTION



Whatever field power you supply is connected to the internal field-power bus. **For example, if 120V ac is applied to the power connections, there will be 120V ac applied to the modules through the internal field-power bus.**

POINT I/O modules to the right of the module will also have that internal power bus voltage applied, unless you use a 1734-FPD to interrupt and change the field power-bus voltage.

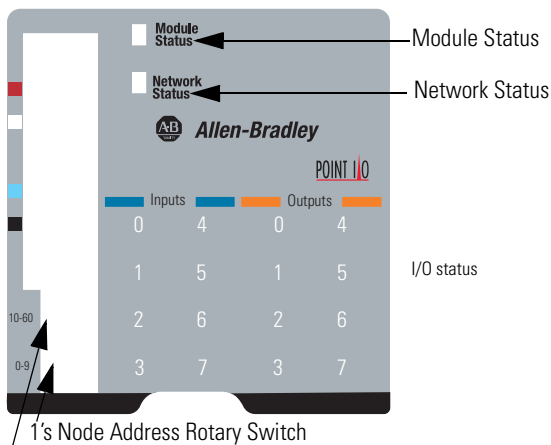

10's Node Address Rotary Switch

42004

To set the node address, set the combination of 1's and 10's to correspond to the required address. (For example, for 61, set the 10's switch to 6 and the 1's switch to 1.)

Wiring the 8 Input/8 Output Module

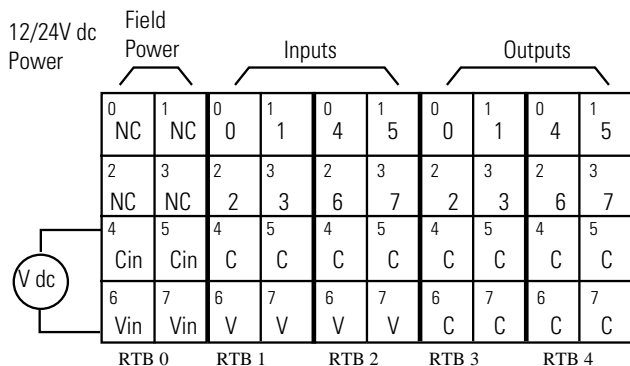

This supply will be connected to the internal power bus.

NC = No Connection

Chas Gnd = Chassis Ground

C = Common

V = Supply

42064

Input Wiring

Sink Input

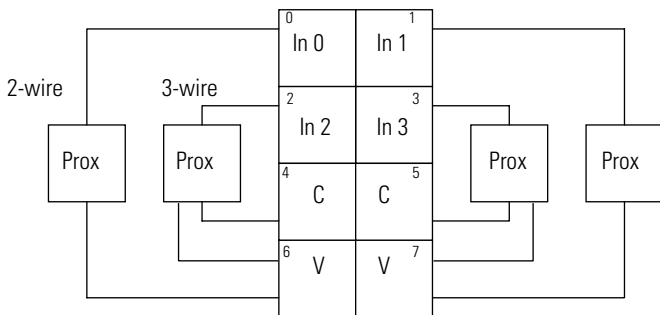

V = 12/24V dc

C = Common

41967

Channel	Input Terminal	Common	Voltage
Remote Termination Block 1			
0	0	4	6
1	1	5	7
2	2	4	6
3	3	5	7
Remote Termination Block 2			
4	0	4	6
5	1	5	7
6	2	4	6
7	3	5	7

Connect common on 3-wire proximity switches.
12/24V dc is supplied through the internal power bus.

Note: When connecting more than 1 wire in a termination point, make sure that both wires are the same gauge and type.

Output Wiring

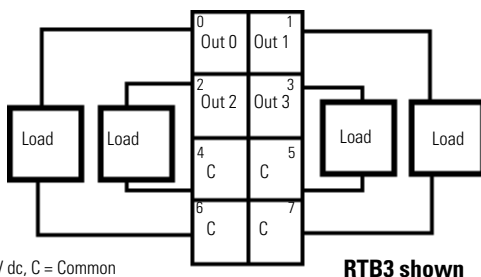

V = 12/24V dc, C = Common
Field power is supplied from internal power bus

42015

	Output Terminal	Common Terminal	Power
Remote Termination Block 3			
Channel 0	0	4	
Channel 1	1	5	
Channel 2	2	6	
Channel 3	3	7	
Remote Termination Block 4			
Channel 4	0	4	
Channel 5	1	5	
Channel 6	2	6	
Channel 7	3	7	

Module power is supplied from the internal power bus.

Note: When connecting more than 1 wire in a termination point, make sure that both wires are the same gauge and type.

Outputs are electronically protected to 0.75A. Module outputs are selectable for latched mode or auto-reset mode. (Latched/auto reset is set by module, not by individual channel.) Each channel is assigned a bit in the data table to indicate the faulted condition. Outputs in the latched mode can only be reset with a user command to the module.

Latch Mode Functionality

State	Indication	Error Bit
Off	Dark	0
On	Yellow	0
Faulted/On	Red	1
Faulted/Off	Flashing Red	1

To reset an output, the reset bit for the output can be set, or the output bit must be cycled off/on.

Auto Retry Mode Functionality







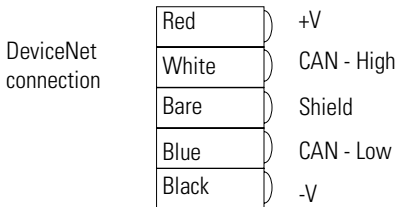

State	Indication	Error Bit
Off	Dark	0
On	Yellow	0
Faulted/On	Red	1
Faulted/Off	Flashing Red	1

In auto retry, the output will recover once the fault is removed.

DeviceNet Connector Wiring



42132

C-UL and UL Hazardous Location Approval	Approbation d'utilisation dans des environnements dangereux par la C-UL/UL
<p>C-UL and UL certifies products for general use as well as for use in hazardous locations. Actual C-UL and UL certification is indicated by the product label as shown below, and not by statements in any user documentation.</p>	<p>La C-UL/UL certifie des produits pour une utilisation générale aussi bien que pour une utilisation en environnements dangereux. La certification C-UL/UL en vigueur est indiquée par l'étiquette produit et non par des indications dans la documentation utilisateur.</p>
<p>Example of the C-UL and UL certification product label:</p> <div style="display: flex; justify-content: space-around; align-items: center;"> <div style="text-align: center;"> <p>LISTED</p>  <p>C UL US</p> </div> <div style="text-align: center;"> <p>CL I, DIV 2 GP A,B,C,D TEMP</p>  </div> </div>	<p>Exemple d'étiquette de certification d'un produit par la C-UL/UL :</p> <div style="display: flex; justify-content: space-around; align-items: center;"> <div style="text-align: center;"> <p>LISTED</p>  <p>C UL US</p> </div> <div style="text-align: center;"> <p>CL I, DIV 2 GP A,B,C,D TEMP</p>  </div> </div>
<p>To comply with C-UL and UL certification for use in hazardous locations, the following information becomes a part of the product literature for this C-UL and UL-certified industrial control product.</p> <ul style="list-style-type: none"> This equipment is suitable for use in Class I, Division 2, Groups A, B, C, D, or non-hazardous locations only. The products having the appropriate C-UL and UL markings (that is, Class I, Division 2, Groups A, B, C, D) are certified for use in other equipment where the suitability of combination (that is, application or use) is determined by the C-UL and UL or the local inspection office having jurisdiction 	<p>Pour satisfaire à la certification C-UL/UL en environnements dangereux, les informations suivantes font partie intégrante de la documentation des produits de commande industrielle certifiés.</p> <ul style="list-style-type: none"> Cet équipement ne convient qu'à une utilisation en environnements de Classe I, Division 2, Groupes A, B, C, D ou non dangereux. Les produits portant le marquage C-UL/UL approprié (c'est-à-dire Classe I, Division 2, Groupes A, B, C, D) sont certifiés pour une utilisation avec d'autres équipements, les combinaisons d'applications et d'utilisations étant déterminées par la C-UL/UL ou le bureau local d'inspection qualifié.
<p>Important: Due to the modular nature of a programmable control system, the product with the highest temperature rating determines the overall temperature code rating of a programmable control system in a Class I, Division 2, location. The temperature code rating is marked on the product label as shown.</p>	<p>Important: De par la nature modulaire des systèmes de commande programmables, le produit ayant le code de température le plus élevé détermine le code de température global du système dans un environnement de Classe I, Division 2. Le code de température est indiqué sur l'étiquette produit.</p>
<p>Temperature code rating:</p> <div style="display: flex; justify-content: space-around; align-items: center;"> <div style="text-align: center;"> <p>LISTED</p>  <p>C UL US</p> <p>Look for temperature code rating here.</p> </div> <div style="text-align: center;"> <p>CL I, DIV 2 GP A,B,C,D TEMP</p>  </div> </div>	<p>Code de température :</p> <div style="display: flex; justify-content: space-around; align-items: center;"> <div style="text-align: center;"> <p>LISTED</p>  <p>C UL US</p> <p>Le code de température est indiqué ici.</p> </div> <div style="text-align: center;"> <p>CL I, DIV 2 GP A,B,C,D TEMP</p>  </div> </div>
<p>The following warnings apply to products having C-UL and UL certification for use in hazardous locations.</p>	<p>Les avertissements suivants s'appliquent aux produits ayant la certification C-UL/UL pour une utilisation en environnements dangereux.</p>
<p>WARNING: Explosion Hazard</p> <ul style="list-style-type: none"> Substitution of components may impair suitability for Class I, Division 2. Do not replace components unless power has been switched off or the area is known to be non-hazardous. Do not disconnect equipment unless power has been switched off or the area is known to be non-hazardous. Do not disconnect connectors unless power has been switched off or the area is known to be non-hazardous. <p>Secure any user-supplied connectors that mate to external circuits on this equipment by using screws, sliding latches, threaded connectors, or other means such that any connection can withstand a 15 Newton (3.4 lb.) separating force applied for a minimum of one minute.</p>	<p>AVERTISSEMENT : Risque d'explosion</p> <ul style="list-style-type: none"> La substitution de composants peut rendre ce matériel inadapté à une utilisation en environnements de Classe I, Division 2. Couper le courant ou s'assurer que l'environnement est classé non dangereux avant de remplacer des composants. Couper le courant ou s'assurer que l'environnement est classé non dangereux avant de débrancher l'équipement. Couper le courant ou s'assurer que l'environnement est classé non dangereux avant de débrancher les connecteurs. Fixer tous les connecteurs fournis par l'utilisateur pour se brancher aux circuits externes de cet équipement à l'aide de vis, loquets coulissants, connecteurs filetés ou autres, de sorte que les connexions résistent à une force de séparation de 15 Newtons (1,5 kg - 3,4 lb.) appliquée pendant au moins une minute. S'assurer que l'environnement est classé non dangereux avant de changer les piles.
<p>C-UL and UL logo is a registered trademark of the Underwriters Laboratories.</p>	<p>Les sigles C-UL et UL sont des marques déposées de la Underwriters Laboratories.</p>

Specifications - 1734D-IB8XOB8E, -IB8XOB8ES**Input Specifications - IEC 1+ 24V dc Input Compliant**

ON-State Voltage Range	10V dc min 24V dc nominal 28.8V dc max
ON-State Current	2.5mA min 6.3mA nominal @ 24V dc 7.6mA max
OFF-State Voltage	5V dc max
OFF-State Current	1.5mA min
Input Impedance	4.7K Ω max (3.6K Ω nominal)
Input Filter Time OFF to ON ON to OFF	0.5ms hardware + (0 - 65ms selectable) 0.5ms hardware + (0 - 65ms selectable)

Output Specifications

ON-State Voltage Range	10V dc min 24V dc nominal 28.8V dc max
ON-State Voltage Drop	0.2V max @ 0.75A
ON-State Current	0.7A max (electronically protected)
OFF-State Voltage	1.5V dc max

General Specifications

Pointbus Output Current	1A max @ 5V dc output power
DeviceNet Current	95mA maximum for POINTBlock 350mA for maximum with expansion of 12 POINT I/O modules
Number of POINT I/O Expansion Modules	12 maximum at expansion port
Isolation Voltage	1250Vrms or 2121V dc for 1s between user power and DeviceNet
Indicators	1 red/ green module status indicator 1 red/green network status indicator 16 I/O status indicators (8 input/8 output)
Power Dissipation	2.0W maximum @ 24V dc
Power Consumption	8.2W maximum @ 24V dc
Field Power Bus Supply Voltage Voltage Range Supply Current	24V dc nominal 10-28.8V dc 10A max

Dimensions Inches (Millimeters)	3.00H x 2.36W x 5.25L (76.2 Hx 60.0W x 133.4L)
Environmental Conditions	
Operational Temperature	-20 to +55°C (-4 to +131°F)
Storage Temperature	-40 to 85°C (-40 to 185°F)
Relative Humidity	5 to 95% noncondensing
Shock Operating	30g peak acceleration, 11(±1)ms pulse width
Non-operating	50g peak acceleration, 11(±1)ms pulse width
Vibration	Tested 5g @ 10-500Hz per IEC 68-2-6
Conductors Wire Size	14 AWG (2.5mm ²) - 22 AWG (0.25mm ²) solid or stranded max
Category	3/64 inch (1.2mm) insulation max 2 ¹
Terminal Base Screw Torque	5-7 pound-inches (0.5-0.6 Nm)
Field Wiring Terminations DeviceNet	1 - Black Wire -V 2 - Blue Wire CAN Low 3 - Bare Wire Drain 4 - White Wire CAN High 5 - Red Wire +V
Field Power Supply	0 - No Connection 1 - No Connection 2 - No Connection 3 - No Connection 4 - Common 5 - Common 6 - Supply 7 - Supply
Mass	12.02 oz/340.77 grams
Agency Certification (when product is marked)	<ul style="list-style-type: none"> • C-UL Listed • C-UL Class I, Division 2 Groups A, B, C and D certified • UL listed • CE marked for all applicable directives • C-Tick marked for all applicable acts
<p>¹ Use this conductor category information for planning conductor routing. Refer to publication 1770-4.1, "Industrial Automation Wiring and Grounding Guidelines for Noise Immunity."</p>	

www.rockwellautomation.com

Power, Control and Information Solutions Headquarters

Americas: Rockwell Automation, 1201 South Second Street, Milwaukee, WI 53204-2496 USA, Tel: (1) 414.382.2000, Fax: (1) 414.382.4444

Europe/Middle East/Africa: Rockwell Automation, Vorstlaan/Boulevard du Souverain 36, 1170 Brussels, Belgium, Tel: (32) 2 663 0600, Fax: (32) 2 663 0640

Asia Pacific: Rockwell Automation, Level 14, Core F, Cyberport 3, 100 Cyberport Road, Hong Kong, Tel: (852) 2887 4788, Fax: (852) 2508 1846

Publication 1734-IN020A-EN-P - July 2001

PN 957236-87

© 2001 Rockwell International Corporation. Printed in USA