

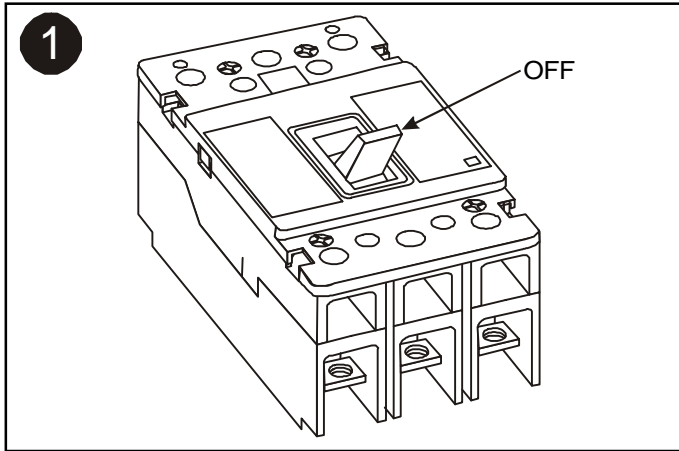

## H-Frame Circuit Breaker Instruction Leaflet for Fixed and Adjustable Thermal Trip



### Warning



DO NOT ATTEMPT TO INSTALL OR PERFORM MAINTENANCE ON EQUIPMENT WHILE IT IS ENERGIZED. DEATH OR SEVERE PERSONAL INJURY CAN RESULT FROM CONTACT WITH ENERGIZED EQUIPMENT. ALWAYS VERIFY THAT NO VOLTAGE IS PRESENT BEFORE PROCEEDING.

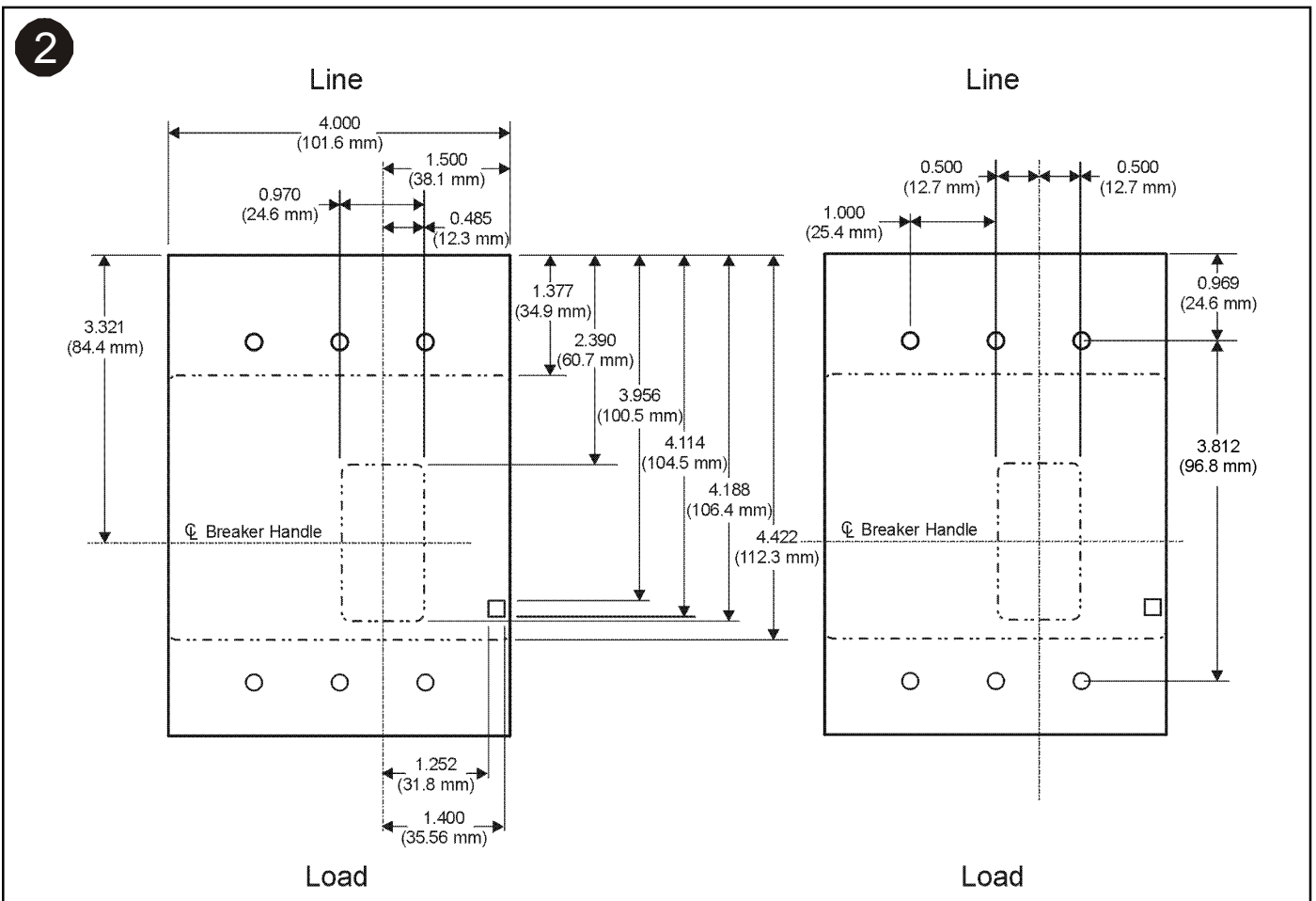



3

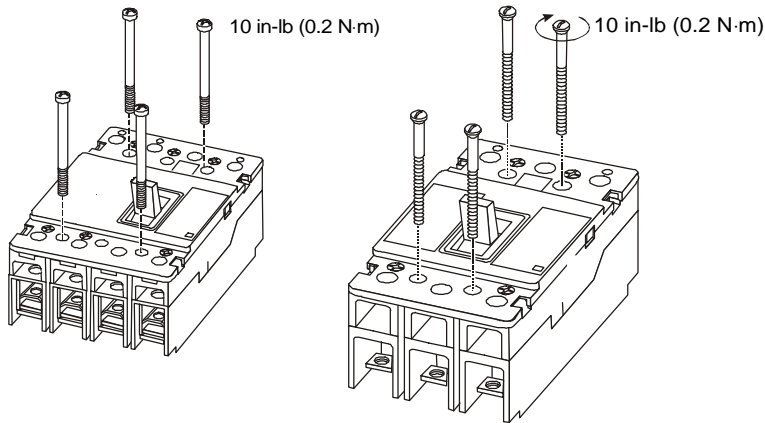

Note: Mounting hardware included. Use nuts (provided) if not threading holes in mounting surface.

4

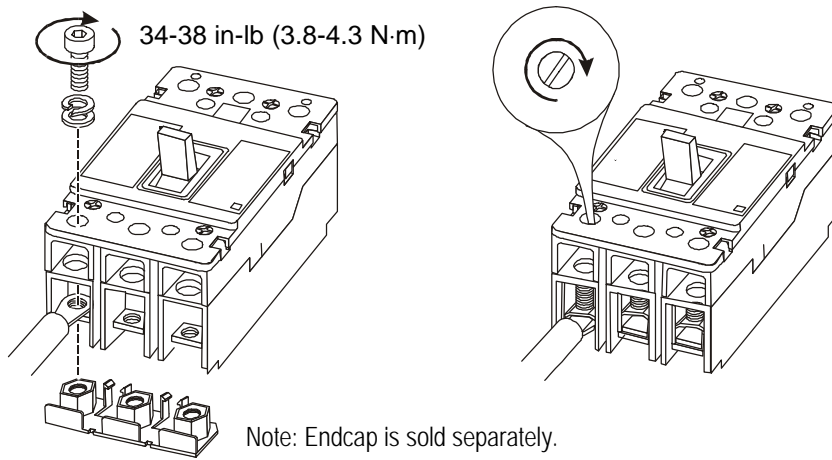

Note: Endcap is sold separately.

### H Frame Collar Torque Values

Wire Size		Torque	
AWG	(mm <sup>2</sup> )	In-lb	(N-m)
14-10	(2.5-6)	35	(4.0)
8	(10)	40	(4.5)
6-4	(16-25)	45	(5.1)
3-3/0	(35-95)	50	(5.6)



**Warning**

**INSTALL WIRE APPLICABLE TO THE HIGHEST RATING SHOWN ON BREAKER.**

5

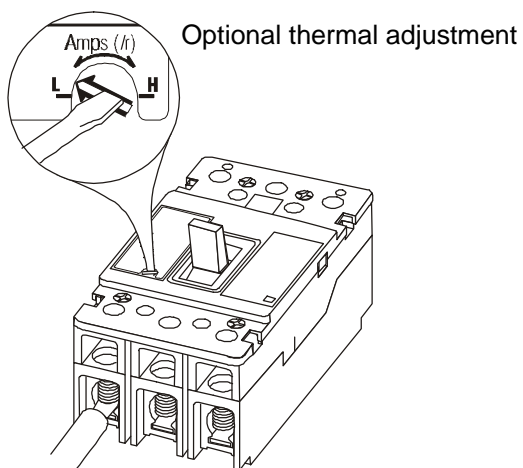

6

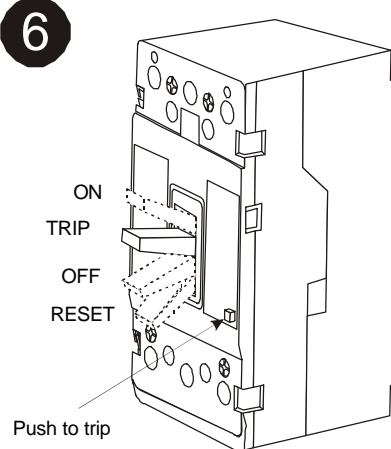

Note: If cover must be removed for accessory installation, torque cover mounting screws to 6-8 in-lb (.7-.9 N-m).