



## 1336 FORCE™ Firmware Upgrade Kit

Version 3.xx to Version 5.01 upgrade

This publication will guide you through installation of a version 5.01 firmware upgrade kit for the 1336 FORCE Digital AC Drive. The 5.01 upgrade allows the FORCE drive to be used with ControlNet Adapter option GT3EN.

### Kit Contents

This kit (P/N 192409) contains the following components:

Part No.	Description	Qty
192410	Instruction Sheet	1
74002-113-01 (02)	User Manual (FORCE 5.12)	1
133256	ESD Wrist Strap	1
74101-900-07	CP Memory Chip	1
74101-902-08	VP Memory Chip	1
	Label "54"	1
	Label "A"	1
	Label "SP51A"	1
	Label "74101-774-54 Rev A"	1

If any of the items are missing from this kit, please contact GTS to obtain a replacement.

### Installation



**ATTENTION:** This drive contains ESD (Electrostatic Discharge) sensitive parts and assemblies. Static control precautions are required when installing, testing, servicing or repairing this assembly. Component damage may result if ESD control procedures are not followed. If you are not familiar with static control procedures, reference A-B publication 8000-4.5.2, "Guarding Against Electrostatic Damage" or any other applicable ESD protection handbook.



**ATTENTION:** To avoid a shock hazard, assure that all power to the drive has been removed before proceeding with the following procedure.

This kit provides two new memory chips which will be installed on the Main Control Board of the 1336 FORCE drive.

Install the kit as follows:

1. Remove power from the drive.
2. Attach the ESD wrist strap to the Drive chassis and to your wrist.
3. Open the cover of the FORCE drive to obtain access to the Main Control Board.
4. Locate the UMC1 and UMC3 chips on the Main Control Board (see following figure). Remove the chips from the control board with a chip puller or a small flat blade screwdriver. Discard the chips.

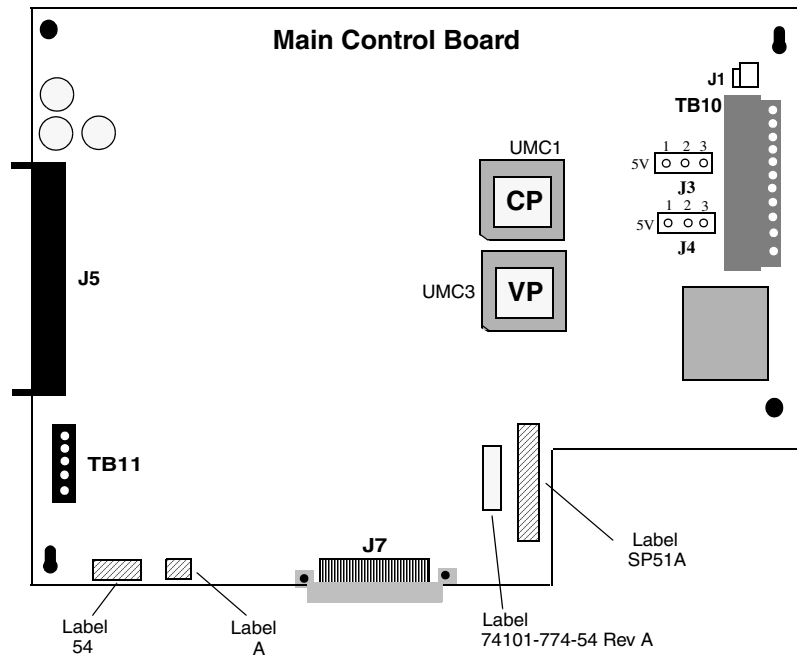

5. Insert the new CP, UMC1. Proper orientation in the socket is required to prevent damaging the assembly. Take Note of the of the marking for pin 1 and the corner flat in the lower left hand corner. The label on the new chip should read:

**74101-  
900-07  
CP  
V5.01**

- 
1. Insert the new VP, UMC3. Proper orientation in the socket is required to prevent damaging the assembly. Take Note of the of the marking for pin 1 and the corner flat in the lower left hand corner. The label on the new chip should read:

**74101-  
902-08  
VP  
V5.01**

2. Apply the new labels to the Main Control Board as shown in the diagram.
3. Close the cover and apply power to the Drive.
4. Initialize the drive to its default values.
  - a. Using a HIM or hand-held display terminal access the EEPROM/BRAM menu.
  - b. Choose “Init Par to RAM”
  - c. Save the parameters to EE when prompted or by choosing “Save Par to EE” in the EEPROM/BRAM menu.
  - d. Reconfigure the drive for your specific application.

[www.rockwellautomation.com](http://www.rockwellautomation.com)

---

**Power, Control and Information Solutions Headquarters**

Americas: Rockwell Automation, 1201 South Second Street, Milwaukee, WI 53204-2496 USA, Tel: (1) 414.382.2000, Fax: (1) 414.382.4444

Europe/Middle East/Africa: Rockwell Automation, Vorstlaan/Boulevard du Souverain 36, 1170 Brussels, Belgium, Tel: (32) 2 663 0600, Fax: (32) 2 663 0640

Asia Pacific: Rockwell Automation, Level 14, Core F, Cyberport 3, 100 Cyberport Road, Hong Kong, Tel: (852) 2887 4788, Fax: (852) 2508 1846