



Upgrading the 1336 PLUS AC Drive to a 1336 PLUS II

1336F-UPGRA & 1336F-UPGRB

This publication will guide you through the steps required to convert a 1336 PLUS Adjustable Frequency AC Drive to a 1336 PLUS II. Performing this conversion will provide you with the updated features of the 1336 PLUS II Drive.

The upgrade can only be performed on the following 1336 PLUS Drives:

- IP00 (Open Type) A-G Frame Drives
- IP20 (NEMA Type 1) A-C Frame Drives

Please note that the upgrade can not be performed on D-G Frame IP20 (NEMA Type 1) Drives.

Items included in the kit include:

Item	Quantity/Kit	
	1336F-UPGRA	1336F-UPGRB
Main Control Board	1	1
HIM and HIM Cradle	1	1
1336 Plus II User Manual	1	1
Plus II Labels, Front Cover	1	1
Plus II Upgrade Sticker	1	1
Wrist Strap	1	1
Terminal Guard, Clear	1	–
Screws, HIM	4	4
Screws, Main Control Board	6	9

Required Tools

- #2 Phillips Screwdriver
- Medium Flat Blade Screwdriver
- VOM or other voltage checking device

Conversion Procedure



ATTENTION: The drive contains ESD (Electrostatic Discharge) sensitive parts and assemblies. Static control precautions are required when installing, testing, servicing or repairing this assembly. Component damage may result if ESD control procedures are not followed. If you are not familiar with static control procedures, reference publication 8000-4.5.2, “Guarding Against Electrostatic Damage” or any other applicable ESD protection handbook.



ATTENTION: To avoid a shock hazard, assure that all power to the drive has been removed before proceeding. In addition, verify that the DC bus has discharged by measuring across the “+DC” and “–DC” terminals of TB1 with a voltmeter. The voltage should be 0.0VDC.

Figure 1
1336 PLUS Board Removal

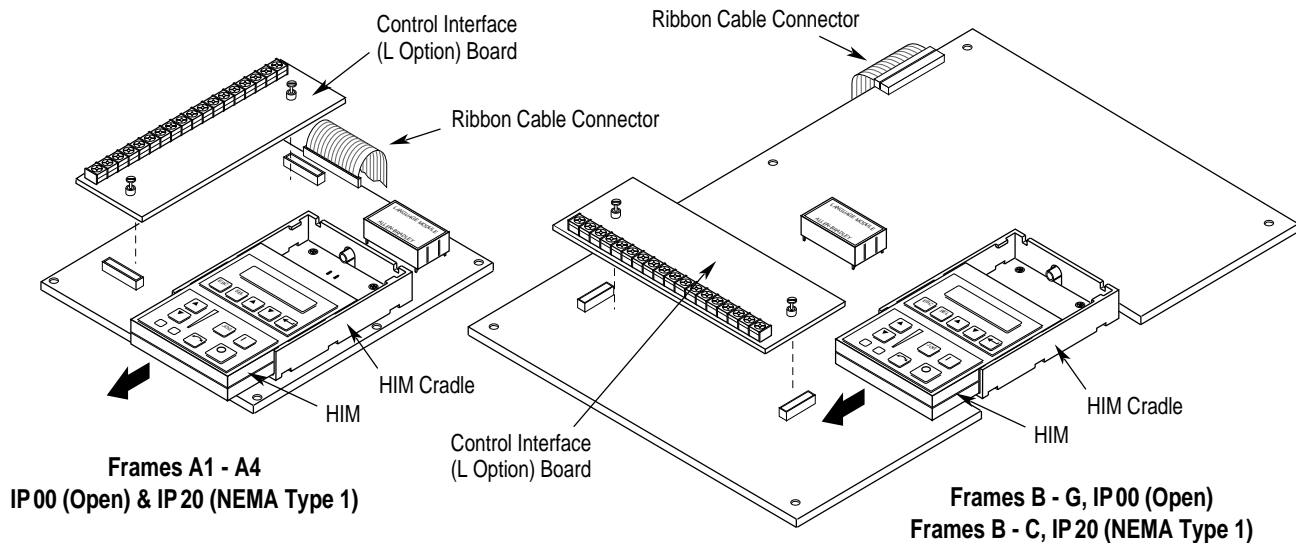

Removing the Existing Main Control Board

Refer to Figure 1 for component identification and locations.

1. Remove and lock-out all incoming power to the drive.
2. Remove/open front cover or remove entire enclosure (on smaller drives) as required for adequate access.
3. Put the supplied wrist strap on.
4. If a Control Interface Board (L option) is installed, carefully remove the board by loosening the 2 captive screws. Position the board and attached wires off to the side of the chassis.
5. *B-G Frame IP00 (Open) or B-C Frame IP20 (NEMA Type 1) Drives Only*
If a Communications Option (1336-GM1, etc.) is installed in the Adapter 6 location, remove it and transfer it to the new Main Control Board.
6. If a HIM (or blank cover) is installed, remove it. Remove the screws securing the HIM cradle. Remove and discard the cradle.
7. Label and remove all wires from TB2.
8. Carefully remove (noting orientation) the flat ribbon cable from the connector at the top of the Main Control Board.
9. Label and remove any remaining cables/wires from the board.
10. Remove the screws securing the Main Control Board. Remove and discard the board. On B-G Frame IP00 (Open) or B-C Frame IP20 (NEMA Type 1) Drives, remove the board from the mounting plate (mounting plate should remain in place).

Installing the New Main Control Board

Refer to Figure 2 for component identification and locations.

11. Carefully position and secure the new Main Control Board using the supplied screws. *A Frame Drives Only* – Do not install a screw in the lower right mounting hole.

Figure 2
Installing the New Main Control Board

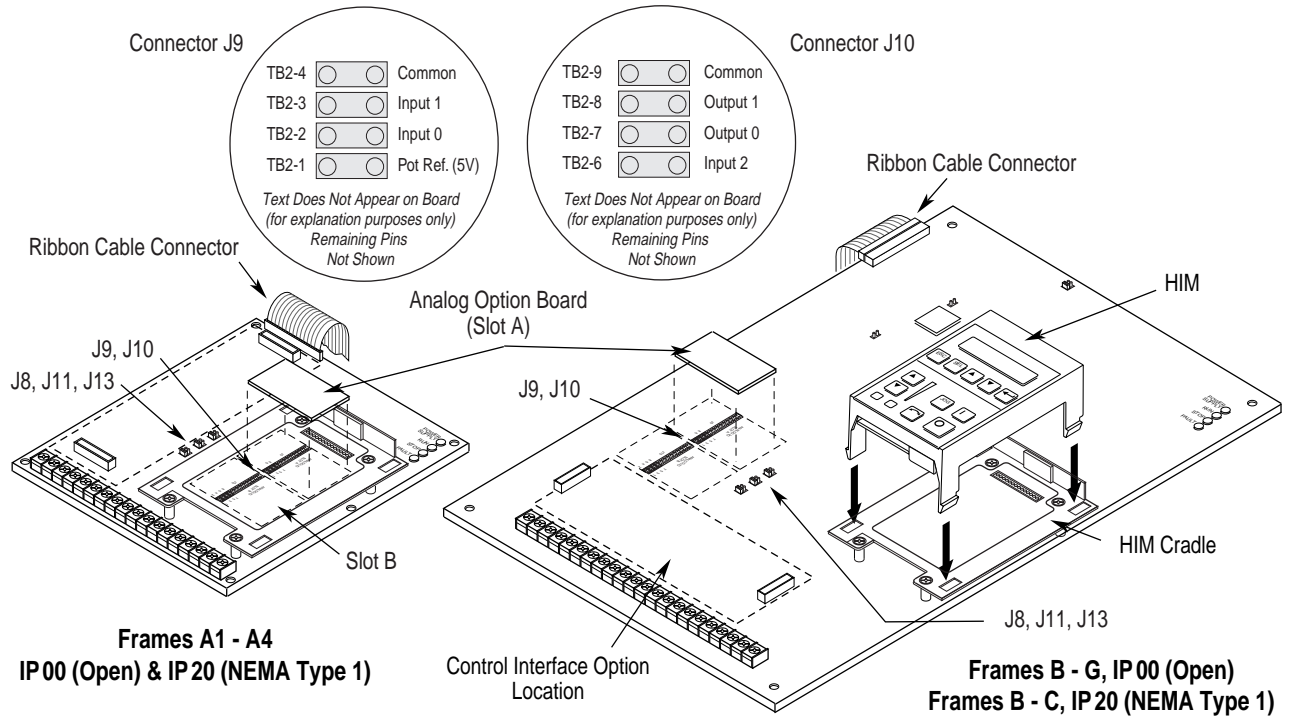

12. If Analog I/O Option Boards (LA1, LA2, etc.) are going to be used, they should be installed at this time using the instructions included with the option.

13. If analog options are not used or only one option board has been installed, the Main Control Board must be configured to utilize the Standard Analog I/O.

A. A series of jumpers are used to connect the standard I/O to TB2 when analog options (LA1, LA2, etc.) are not present. Connectors J9 and J10 (see Figure 2) each have four jumpers connecting pins 1-2, 3-4, 5-6 and 7-8. These jumpers must be in place for the inputs and outputs to be active at TB2.

Important: Note that jumpers for inputs 0, 1 and 2 are not located in logical order on the board.

Important: If only one analog option has been installed, the remaining slot must have the jumpers installed.

B. Each input (Input 0, 1, 2) can be configured for 0-10V, 0-20 mA or potentiometer. Placing a jumper across the top of the connector (J8, J11, J13) configures that input for 0-10V operation (see diagram). The bottom provides 0-20 mA and the right-side provides potentiometer operation. Factory default for all three are 0-10V.

Standard Analog I/O Jumpers

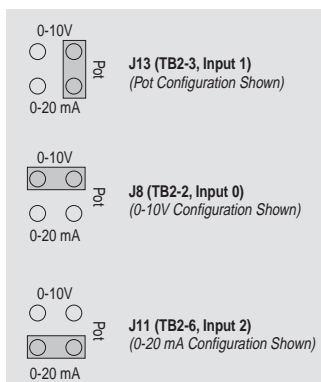

14. **A Frame Drives Only** – Locate the clear plastic terminal guard (supplied). Remove the protective strip and place the guard over the bottom two mounting feet of the cradle. Press the guard onto the back of the cradle.

15. Install the new cradle using the four screws supplied.

16. Install the new HIM by placing the two right side tabs into their respective slots – verify that the tabs are engaged. Carefully “roll” the HIM to the left, engaging the guide tab at the top of the HIM into the guide slot mounted on the board. Verify that the HIM connector engages correctly into the socket on the Main Control Board. Continue until the remaining locking tabs engage.
17. If a Control Interface Board was removed in step 4, install it on the new board and secure with the two captive screws. Remove any jumpers that may be present before installing the board.
18. Re-wire TB2. For wiring information, refer to *Chapter 2* of the *1336 PLUS II User Manual*.



ATTENTION: To guard against drive and/or machine damage, ensure that all connections to TB2 are correct as outlined in *1336 PLUS II User Manual*. Addition of Analog I/O Option Boards or other factors may require a change in wiring from the old Main Control Board.

19. Connect the flat ribbon cable to the connector at the top of the board. Verify that the connector openings match the pin locations.

Important: To guard against connector/drive damage, ensure that the ribbon cable connector is properly aligned with the board connector. Misalignment could result in drive damage.

20. Replace any remaining cables/wires.



ATTENTION: Replace any guards previously removed before applying power to the drive.

21. Replace the drive cover/enclosure.
22. Remove the protective backing from the Upgrade Sticker and place it next to the existing data nameplate (do not place over nameplate).
23. Locate the “1336 PLUS II” labels. Select the size label that corresponds to the existing front cover label. Remove the protective backing and place it over the existing “1336 PLUS” label.
24. Remove wrist strap. Apply power. Reset parameters to factory default and cycle power. Your conversion is now complete



Rockwell Automation helps its customers receive a superior return on their investment by bringing together leading brands in industrial automation, creating a broad spectrum of easy-to-integrate products. These are supported by local technical resources available worldwide, a global network of system solutions providers, and the advanced technology resources of Rockwell.

Worldwide representation.



Argentina • Australia • Austria • Bahrain • Belgium • Bolivia • Brazil • Bulgaria • Canada • Chile • China, People's Republic of • Colombia • Costa Rica • Croatia • Cyprus • Czech Republic • Denmark • Dominican Republic • Ecuador • Egypt • El Salvador • Finland • France • Germany • Ghana • Greece • Guatemala • Honduras • Hong Kong • Hungary • Iceland • India • Indonesia • Iran • Ireland • Israel • Italy • Jamaica • Japan • Jordan • Korea • Kuwait • Lebanon • Macau • Malaysia • Malta • Mexico • Morocco • The Netherlands • New Zealand • Nigeria • Norway • Oman • Pakistan • Panama • Peru • Philippines • Poland • Portugal • Puerto Rico • Qatar • Romania • Russia • Saudi Arabia • Singapore • Slovakia • Slovenia • South Africa, Republic of • Spain • Sweden • Switzerland • Taiwan • Thailand • Trinidad • Tunisia • Turkey • United Arab Emirates • United Kingdom • United States • Uruguay • Venezuela

Rockwell Automation Headquarters, 1201 South Second Street, Milwaukee, WI 53204-2496 USA, Tel: (1) 414 382-2000, Fax: (1) 414 382-4444