



1336 PLUS, 1336 PLUS II, 1336 FORCE™ & 1336 IMPACT™ Junction Box Kit

(Catalog Number 1336-JBxx)

This publication will guide you through installation of the 1336-JBxx Junction Box kit. Refer to the appropriate drive User Manual for detailed drive information.

Installation

Using the following information and the Catalog Number Explanation below, verify that you have the correct components.

- If the catalog number of your drive contains an “AA” (i.e. 1336S-B030-AA-EN4), a junction box with a catalog number that ends in “A” (i.e. 1336-JBBA) is required.
- If the catalog number of your drive contains an “AE” (i.e. 1336S-B050-AE-EN4), a junction box with a catalog number that ends in “E” (i.e. 1336-JBCE) is required.
- If the catalog number of your drive contains an “AN” (i.e. 1336S-B030-AN-EN4), an Allen-Bradley Enclosure Kit and corresponding junction box are required.

Junction Box Catalog Number Explanation

1336		-JB		-B		-E	
<i>First Position</i>		<i>Second Position</i>		<i>Third Position</i>		<i>Fourth Position</i>	
Description		Description		Frame Size		Type	
<i>Description</i>	<i>Bulletin Number</i>	<i>Letter</i>	<i>Description</i>	<i>Letter</i>	<i>Description</i>	<i>Letter</i>	<i>Description</i>
		JB	Junction Box	B	B Frame	A	IP 20 (NEMA Type 1)
				C	C Frame	E	IP 20 (NEMA Type 1) CE



ATTENTION: The drive contains ESD (Electrostatic Discharge) sensitive parts and assemblies. Static control precautions are required when installing, testing, servicing or repairing this assembly. Component damage may result if ESD control procedures are not followed. If you are not familiar with static control procedures, reference A-B publication 8000-4.5.2, “Guarding Against Electrostatic Damage” or any other applicable ESD protection handbook.



ATTENTION: To avoid a shock hazard, assure that all power to the drive has been removed before proceeding. In addition, verify that the DC bus has discharged by measuring across the “+DC” and “-DC” terminals of TB1 with a voltmeter. The voltage should be 0.0VDC.



When a drive mounted HIM is not supplied on enclosed IP 20 (NEMA Type 1) drives, the blank cover plate (option HAB) must be installed to close the opening in the front cover of the enclosure. Failure to install the blank cover plate allows access to electrically live parts which may result in personal injury and/or equipment damage.

When a drive mounted HIM is supplied with enclosed IP 20 (NEMA Type 1) drives, but has been removed from its mounting cradle for remote operation, the blank cover plate must be installed in place of the HIM.

1336 with IP20 (NEMA Type 1) Enclosure

Refer to Figure 1 for dimension information.

1. Remove and lock-out all power to the drive. Remove front cover.
2. Label and disconnect all wiring. External wiring will have to be rerouted through the junction box, once it has been installed.
3. Remove and discard existing bottom plate.
4. Install new bottom plate with junction box. Tighten all screws to 1.5 N-m (13 lb.-in.). Rewire drive and replace front cover.

1336 with IP20 (NEMA Type 1) CE Enclosure

Refer to Figure 1 for dimension information.

1. Access to the top, bottom and sides of the drive chassis will be required. Remove and lock-out all power to the drive.
2. Remove screws securing enclosure assembly to chassis. Remove enclosure.
3. Label and disconnect all wiring. External wiring will have to be rerouted through the junction box, once it has been installed.
4. Remove and discard existing bottom plate. Install the new junction box bottom plate.
5. Rewire drive.
6. Replace enclosure assembly and tighten all screws to 1.5 N-m (13 lb.-in.).

Figure 1
Knockout Dimensions

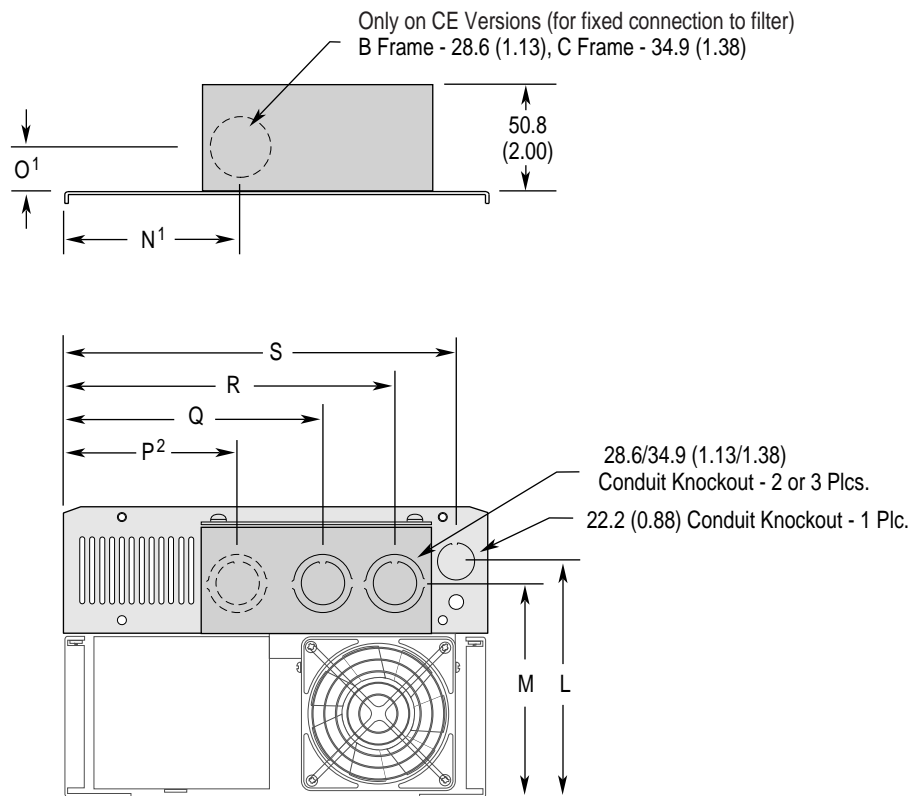

All Dimensions in Millimeters and (Inches)

Frame Reference	L	M	N ¹	O ¹	P ²	Q	R	S
B1/B2	181.6 (7.15)	167.1 (6.58)	NA	NA	106.4 (4.19)	155.2 (6.11)	206.0 (8.11)	249.9 (9.84)
B1/B2 (CE)	181.6 (7.15)	167.1 (6.58)	114.1 (4.49)	20.6 (0.81)	NA	155.2 (6.11)	206.0 (8.11)	249.9 (9.84)
C	181.6 (7.15)	167.1 (6.58)	NA	NA	112.8 (4.44)	174.5 (6.87)	227.8 (8.97)	275.3 (10.84)
C (CE)	181.6 (7.15)	167.1 (6.58)	120.7 (4.75)	25.4 (1.00)	NA	174.5 (6.87)	227.8 (8.97)	275.3 (10.84)

¹ Only present on CE version Junction Boxes.

² Not present on CE Junction Boxes.

1336 FORCE & 1336 IMPACT are trademarks of Rockwell Automation.

Reach us now at www.rockwellautomation.com

Wherever you need us, Rockwell Automation brings together leading brands in industrial automation including Allen-Bradley controls, Reliance Electric power transmission products, Dodge mechanical power transmission components, and Rockwell Software. Rockwell Automation's unique, flexible approach to helping customers achieve a competitive advantage is supported by thousands of authorized partners, distributors and system integrators around the world.

Americas Headquarters, 1201 South Second Street, Milwaukee, WI 53204, USA, Tel: (1) 414 382-2000, Fax: (1) 414 382-4444
European Headquarters SA/NV, avenue Herrmann Debroux, 46, 1160 Brussels, Belgium, Tel: (32) 2 663 06 00, Fax: (32) 2 663 06 40
Asia Pacific Headquarters, 27/F Citicorp Centre, 18 Whitfield Road, Causeway Bay, Hong Kong, Tel: (852) 2887 4788, Fax: (852) 2508 1846

