



## **1321-M Common Mode Chokes**

(Catalog Number 1321-M001, 1321-M009, 1321-M048  
1321-M180, 1321-M670)

### **Where this Option is Used**

The 1321-M Common Mode Choke Options can be installed with 1305, 1336 Plus, 1336 Plus II, 1336 IMPACT™ and 1336 FORCE™ AC drives. When installed at the drive output the common mode choke helps to guard against interference with other electrical equipment (programmable controllers, sensors, analog circuits, etc.). In addition, reducing the PWM carrier frequency reduces the effects and lowers the risk of common mode noise interference. The table on page 2 details the common mode chokes available for each drive rating.

### **What this Option Contains**

Each 1321-M Common Mode Choke Kit includes the Common Mode core and a mounting bracket where applicable. Some models also contain a terminal block and wiring.

### **What these Instructions Contain**

These instructions contain the information you need to properly install a 1321-M Open Style Common Mode choke. Recommended mounting and connection procedures are included. Major topics and page numbers are listed below.

Selection Table .....	2
1321-M001 Mounting and Installation .....	3
1321-M009 Mounting and Installation .....	4
1321-M048 Mounting and Installation .....	5
1321-M180 Mounting and Installation .....	7
1321-M670 Mounting and Installation .....	9
Mounting Dimensions .....	11

**Selection Table**

Refer to the following table when selecting an open style 1321-M type Common Mode Choke for your particular drive.

<b>Choke Type</b>	<b>Used With:</b>	<b>Ratings:</b>	<b>Catalog Number</b>
Open Style, 1A	All Drives	Communication Cables Analog Signal Cables etc.	1321-M001
Open Style, 9A (with terminal strip)	1305, 1336 Plus & Plus II	0.5 - 2HP (0.37-2.2kW) 230V 0.5 - 5HP (0.37-3.7kW) 480V	1321-M009
	1336 IMPACT	0.5 - 5HP (0.37-3.7kW) 480V	
	1336 FORCE	1HP (0.75 kW) 230V 1-3HP (0.75 -2.2 kW) 480	
Open Style, 48A	1336 Plus & Plus II	3-15HP (2.2-11kW) 230V 7.5-30HP (5.5-22kW) 480V 1-40HP (0.75-30kW) 600V	1321-M048
	1336 IMPACT	7.5-30HP (5.5-22kW) 480V 7.5-40HP (5.5-30kW) 600V	
	1336 FORCE	3-15HP (2.2-11kW) 230V 3-30HP (2.2-22kW) 480V 1-40HP (0.75-30kW) 600V	
Open Style, 180A	1336 Plus & Plus II	20-60HP (15-45kW) 230V 40-x150HP (30-112kW) 480V 50-150HP (37-112kW) 600V	1321-M180
	1336 IMPACT	40-x150HP (30-112kW) 480V 50-125HP (37-93kW) 600V	
	1336 FORCE	20-60HP (15-45kW) 230V 40-x150HP (30-112kW) 480V 50-150HP (37-112kW) 600V	
Open Style, 670A	1336 Plus & Plus II	75-125HP (56-93kW) 230V 150-600HP (112-448kW) 480V 200-600HP (149-448kW) 600V	1321-M670A
	1336 IMPACT	150-600HP (112-448kW) 480V 200-600HP (149-448kW) 600V	
	1336 FORCE	75-125HP (56-93kW) 230V 150-600HP (112-448kW) 480V 200-600HP (149-448kW) 600V	

## Installation

All choke assemblies should be mounted as close to the bottom of the drive as possible while leaving sufficient distance between the choke assembly and the drive unit to provide clearance for cables and leads to be installed at the drive. All choke assemblies with the exception of the M001 and M009 are supplied with mounting brackets. Mounting dimensions for each assembly are provided at the back of this publication. It is recommended that M001 and M009 assemblies be tie wrapped to a solid object such as cabinet sheet metal or brackets when wiring is completed.

### M001 Mounting and Wiring

To install the choke assembly, follow these steps:

1. Remove all power connected to the system.



**ATTENTION:** Electric shock can cause injury or death. Remove all power before working with this product. Verify that the voltage on the bus capacitors has discharged. The voltage must be zero.

---

2. Wrap the communication cable thru the choke assembly five times as shown in the following figure. If the wire gauge is too large to allow 5 wraps, you may use fewer wraps but this will diminish the effectiveness of the installation.

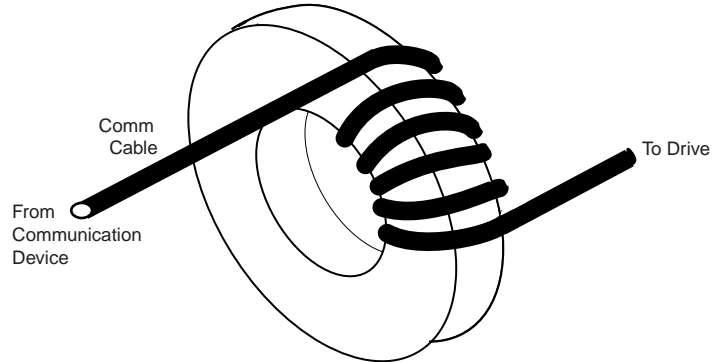

3. Leave enough cable between the choke assembly and the drive to allow the communication cable suitable clearance to be terminated at the drive and for the choke assembly to be mounted near the bottom of the drive cabinet. When all wiring is completed, zip tie the choke assembly to the cabinet sheet metal or another suitable location to provide support for the assembly.

## M009 Mounting and Wiring

To install the choke assembly, follow these steps:

1. Remove all power connected to the system.



**ATTENTION:** Electric shock can cause injury or death. Remove all power before working with this product. Verify that the voltage on the bus capacitors has discharged. The voltage must be zero.

2. A 4 position terminal strip with preinstalled TB leads is included with M009. Install leads from the terminal strip to TB1 (T3/W), (T2/V) and (T1/U) of your drive. Make certain to leave at least 2 inches (50 millimeters) clearance between the choke assembly and the drive terminals. Run the green 12 AWG lead from the terminal strip outside the choke assembly to the PE connection on the drive TB1 as shown in the following figure.
3. Run motor leads from the terminal strip to the T1/U, T2/V, T3/W terminals on the motor as shown in the following figure. Run a 12 AWG ground lead from the terminal block to the ground point on the motor frame.

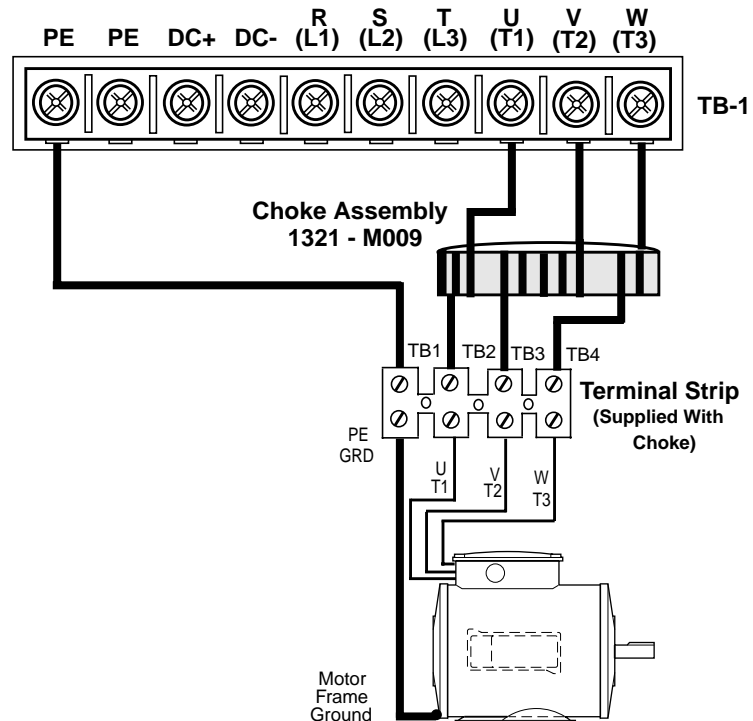

4. When all wiring is completed, tie wrap the choke assembly to the cabinet sheet metal or another suitable location to provide support for the assembly. If the terminal strip supplied with the choke is to be panel mounted, an insulation sheet must be used between the terminal strip and the sheet metal.

## M048 Mounting and Wiring

To install the choke assembly, follow these steps:

1. Remove all power connected to the system.



**ATTENTION:** Electric shock can cause injury or death. Remove all power before working with this product. Verify that the voltage on the bus capacitors has discharged. The voltage must be zero.

2. Mount the M048 Choke Assembly on a metal surface as near as possible to the bottom of the drive cabinet using 1/4-20 hardware. Leave sufficient clearance between the choke assembly and the drive terminals to allow access to the terminals and provide proper bend radius for the leads.
3. Terminate the motor leads at the T1/U, T2/V, T3/W connections on the motor as shown in the following figure. An optional terminal strip may be used between the choke assembly and the motor if desired. A properly sized ground conductor from the motor frame is also required.

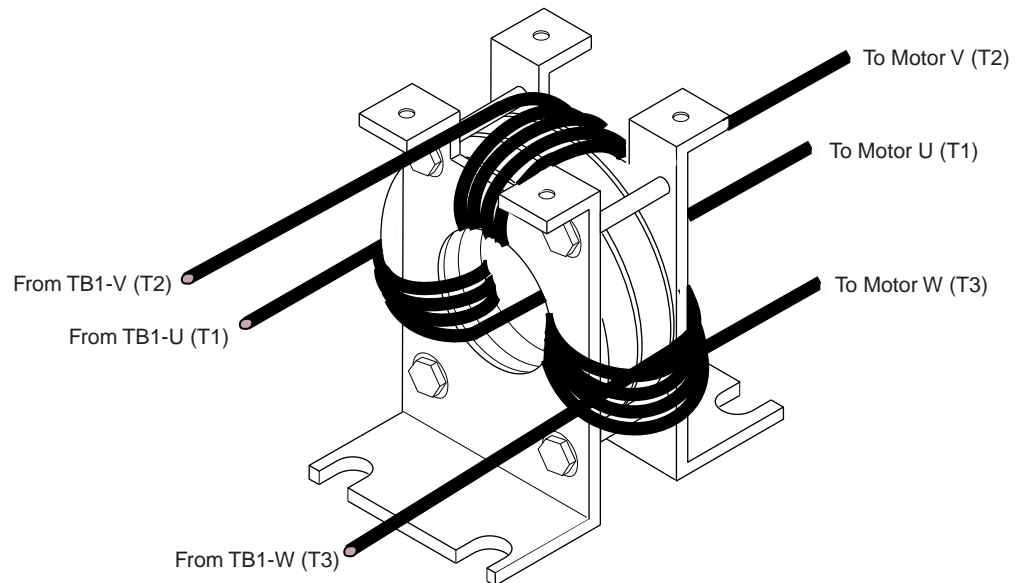

4. Run the leads thru the choke assembly and wrap each lead around the choke four times as shown in the previous figure before running the leads to the drive. Each lead should be wrapped in the same direction starting on the outside of the coil and exiting inside the coil. If possible, maintain a 120° separation of the lead wraps. Install the motor leads at T1 (U), T2 (V) and T3 (W) at terminal block TB1 on your drive.

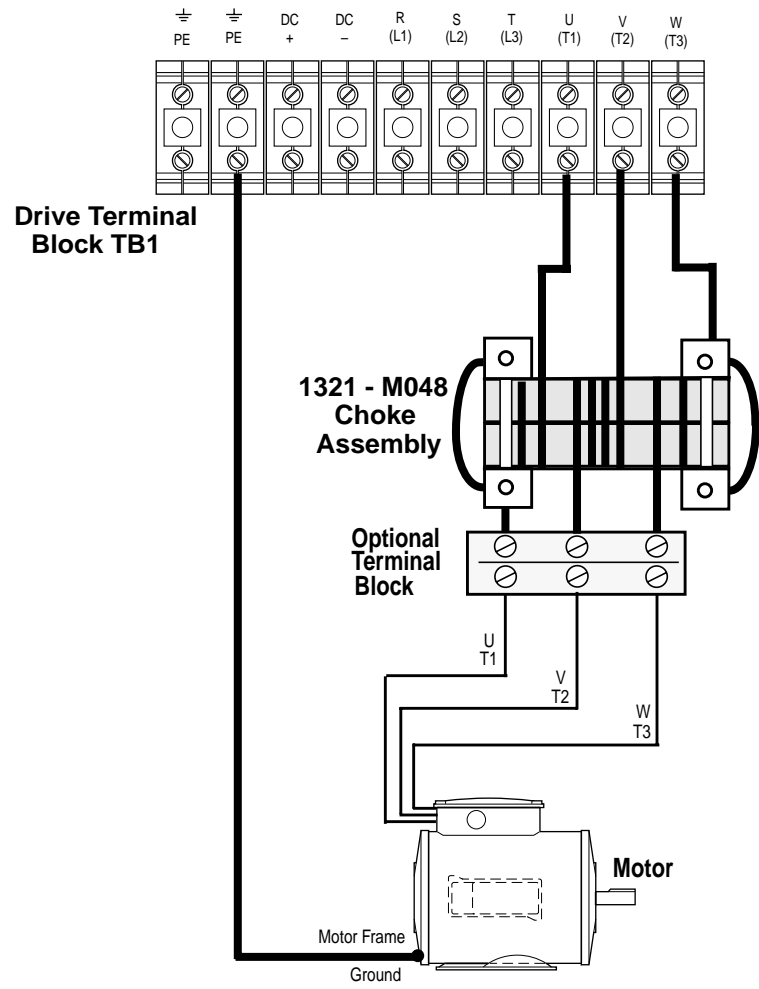

## M180 Mounting and Wiring

To install the choke assembly, follow these steps

1. Remove all power connected to the system.



**ATTENTION:** Electric shock can cause injury or death. Remove all power before working with this product. Verify that the voltage on the bus capacitors has discharged. The voltage must be zero.

2. Mount the M180 Choke Assembly on a metal surface near the bottom of the drive cabinet using 1/4-20 hardware. Leave sufficient clearance between the choke assembly and the drive terminals to allow access to the terminals and provide proper bend radius for the leads.
3. Terminate the motor leads at the T1/U, T2/V, T3/W connections on the motor as shown in the figure on the following page. An optional terminal strip may be used between the choke assembly and the motor if desired. A properly sized ground conductor from the motor frame is also required. The ground conductor is routed around (not through) the choke and connected to the Drive Power Earth @ TB1-PE.

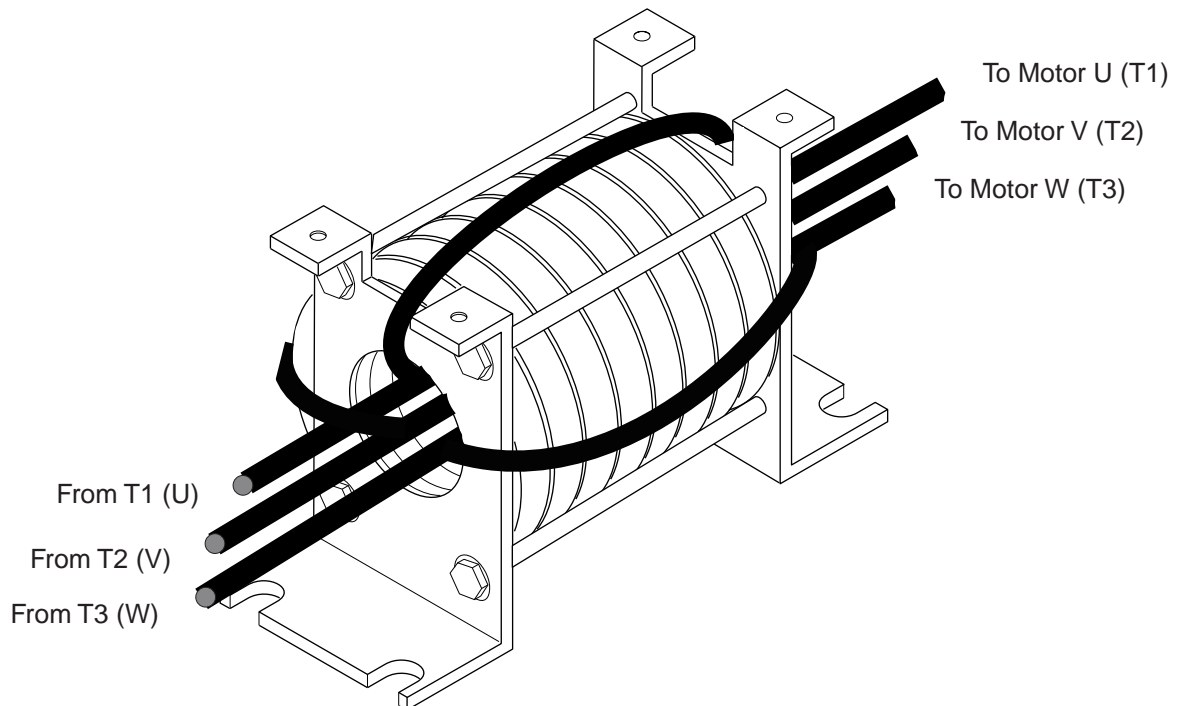

4. If possible, wrap each lead once around the core before terminating at the drive terminals. If the motor lead gauge is too thick to allow one wrap, run the leads straight through the choke assembly to drive terminals TB-1, U (T1), V (T2) and W (T3) as shown in the following figure. Running the motor leads straight thru the core, will diminish the effectiveness of the installation.

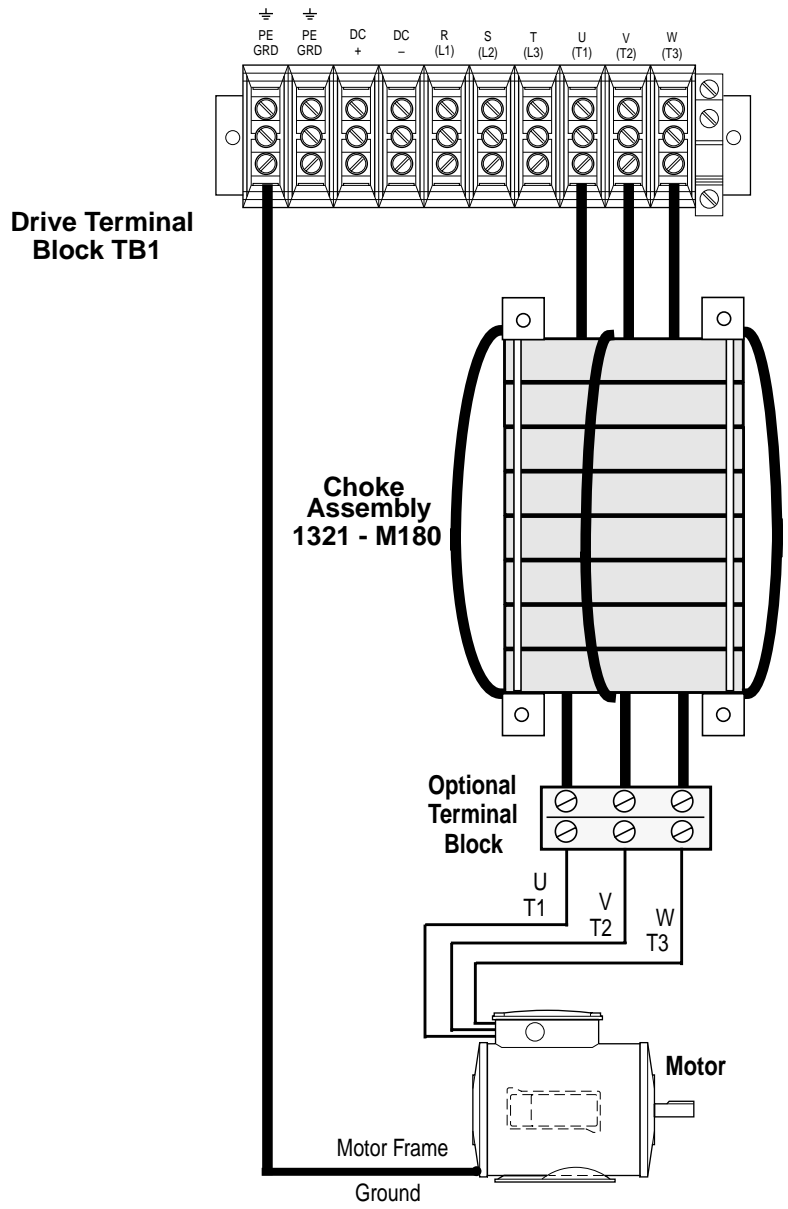

## M670 Mounting and Wiring

To install the choke assembly, follow these steps:

1. Remove all power connected to the system.



**ATTENTION:** Electric shock can cause injury or death. Remove all power before working with this product. Verify that the voltage on the bus capacitors has discharged. The voltage must be zero.

---

2. Mount the M670 Choke Assembly on a metal surface near the bottom of the drive cabinet using 1/4-20 hardware. Leave sufficient clearance between the choke assembly and the drive terminals to allow access to the terminals and provide proper bend radius for the leads.
3. Terminate the motor leads at the U,V,W connections on the motor as shown in the figure on the following page. An optional terminal strip may be used between the choke assembly and the motor if desired. A properly sized ground conductor from the motor frame is also required. The ground conductor is routed around (not through) the choke and connected to the Drive Power Earth @ TB1-PE.

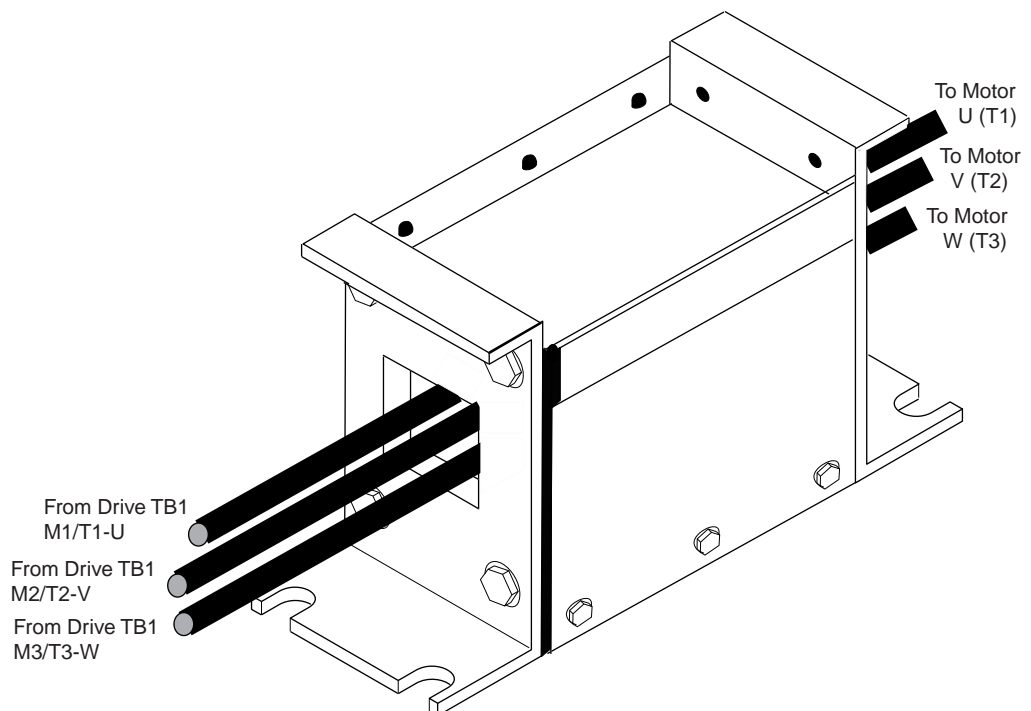

- Run the motor leads straight through the choke assembly and terminate at TB-1 M1/T1-U, M2/T2-V and M3/T3-W as shown in the following figure.

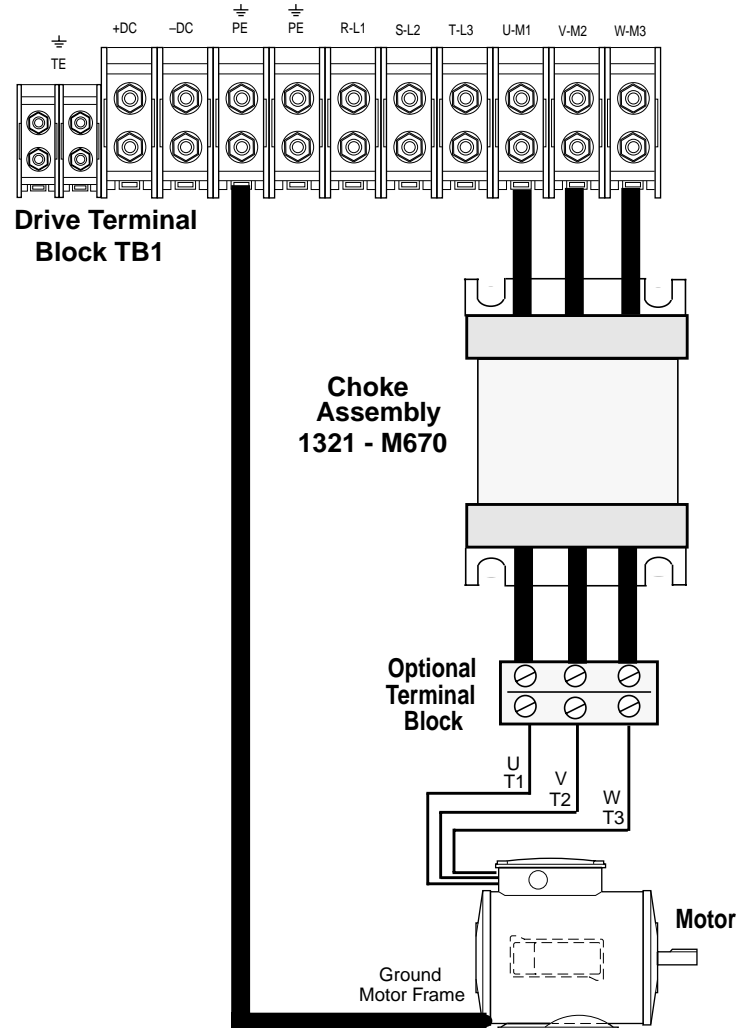

## Mounting Dimensions

Mounting Dimensions for the 1321-M001, 1321-M009, 1321-M048, 1321-M180 and 1321-M670 choke assemblies are detailed in the following schematics:

### 1321-M001

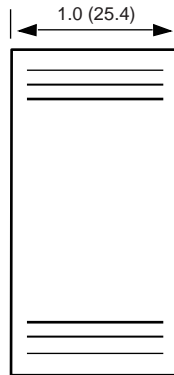

SIDE  
VIEW

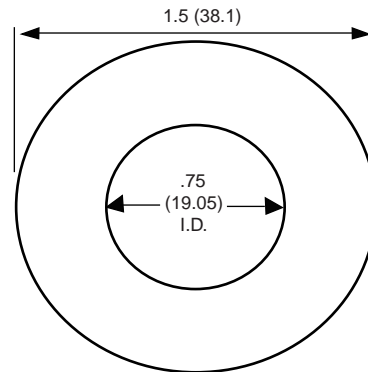

END  
VIEW

### 1321-M009

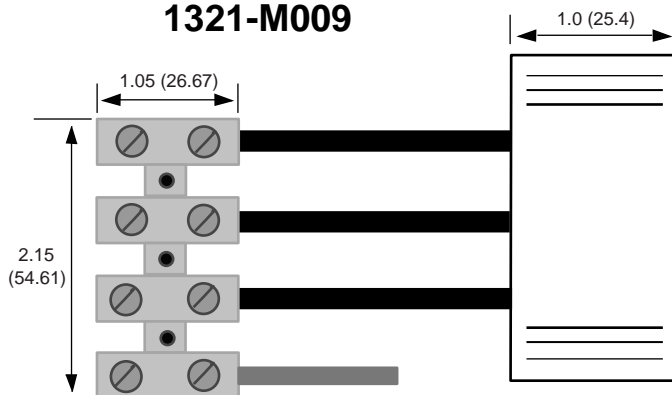

SIDE  
VIEW

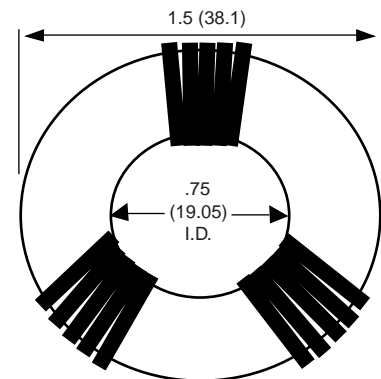

END  
VIEW

Dimensions in inches (mm)

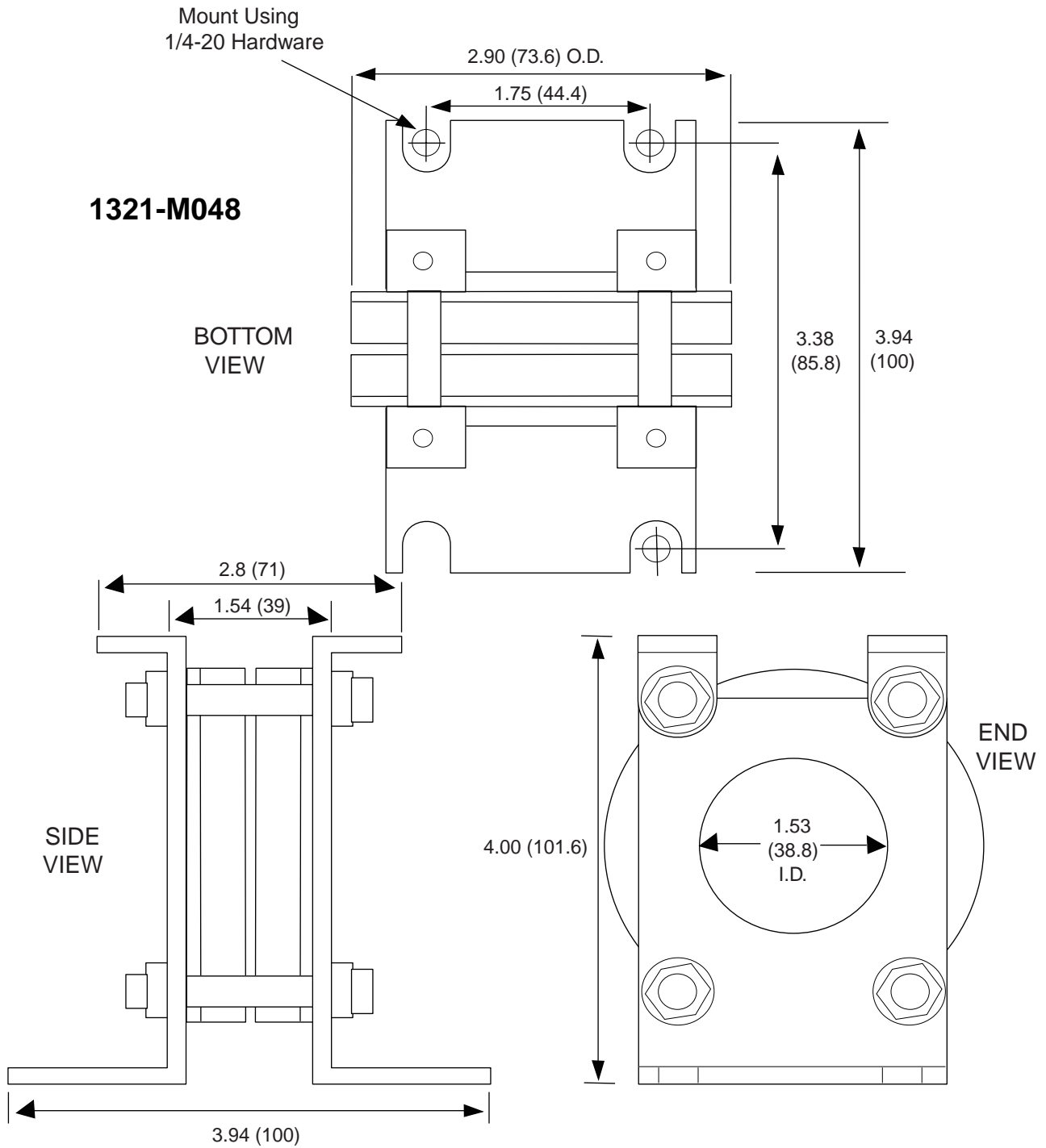

Dimensions in inches (mm)

### 1321-M180

Mount Using  
1/4-20 Hardware

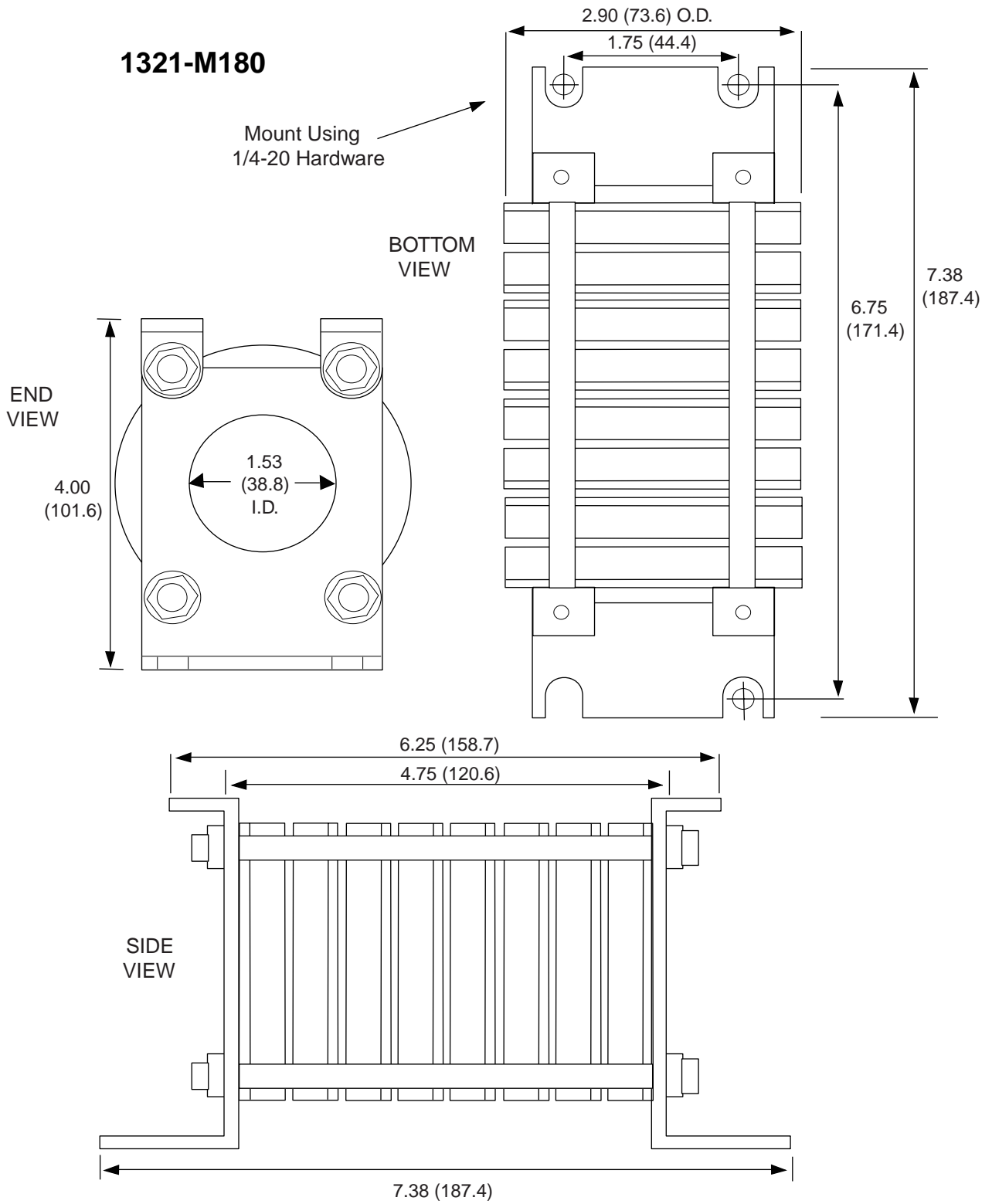

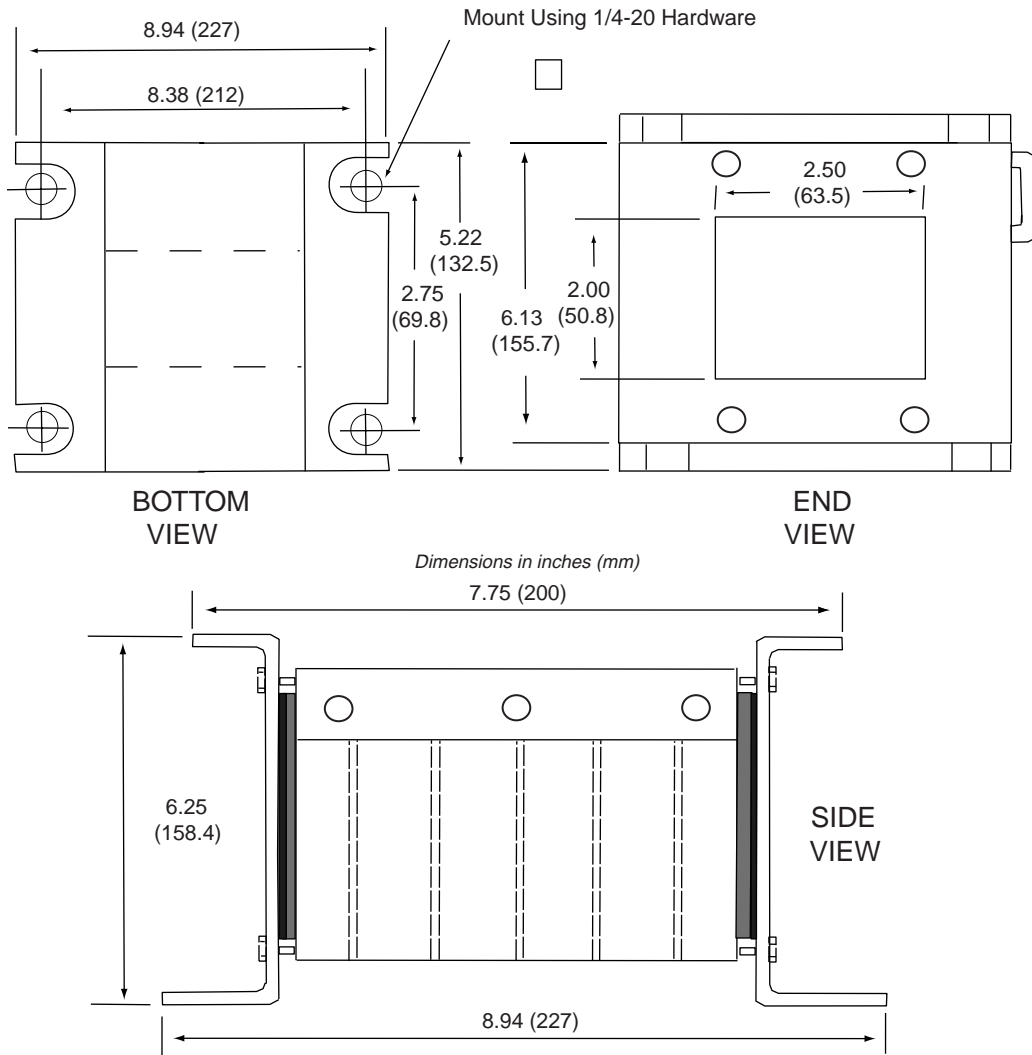
**1321-M670**

**This Page Intentionally Left Blank**



Rockwell Automation helps its customers receive a superior return on their investment by bringing together leading brands in industrial automation, creating a broad spectrum of easy-to-integrate products. These are supported by local technical resources available worldwide, a global network of system solutions providers, and the advanced technology resources of Rockwell.

## Worldwide representation.



Argentina • Australia • Austria • Bahrain • Belgium • Bolivia • Brazil • Bulgaria • Canada • Chile • China, People's Republic of • Colombia • Costa Rica • Croatia • Cyprus • Czech Republic • Denmark • Dominican Republic • Ecuador • Egypt • El Salvador • Finland • France • Germany • Ghana • Greece • Guatemala • Honduras • Hong Kong • Hungary • Iceland • India • Indonesia • Iran • Ireland • Israel • Italy • Jamaica • Japan • Jordan • Korea • Kuwait • Lebanon • Macau • Malaysia • Malta • Mexico • Morocco • The Netherlands • New Zealand • Nigeria • Norway • Oman • Pakistan • Panama • Peru • Philippines • Poland • Portugal • Puerto Rico • Qatar • Romania • Russia • Saudi Arabia • Singapore • Slovakia • Slovenia • South Africa, Republic of • Spain • Sweden • Switzerland • Taiwan • Thailand • Trinidad • Tunisia • Turkey • United Arab Emirates • United Kingdom • United States • Uruguay • Venezuela

Rockwell Automation Headquarters, 1201 South Second Street, Milwaukee, WI 53204-2496 USA, Tel: (1) 414 382-2000, Fax: (1) 414 382-4444

Publication 1321-5.0 – July, 2000

P/N 191386 (02)  
Copyright 1998 Rockwell International Corporation. All rights reserved. Printed in USA.