



1204 Reflected Wave Reduction Device with Common Mode Choke

(Catalog Number 1204-RWC-17-A)

This publication will guide you through installation (including mounting, wiring and grounding procedures) of the 1204 Reflected Wave Reduction Device with Common Mode Choke (1204-RWC).

Contents

[Where this Option is Used](#) [1](#)

[Catalog Number Explanation](#) [1](#)

[Specifications](#) [2](#)

[Nameplate Information](#) [3](#)

[Dimensions](#) [3](#)

[Determining the Maximum Cable Length for your System](#) [4](#)

[Installation](#) [5](#)

Where this Option is Used

The 1204 Reflected Wave Reduction Device with Common Mode Choke (RWC) is designed to be used with Allen-Bradley 1336 family of AC drives with compatible current ratings. Call factory for advice on using the 1204-RWC with drives other than the 1336 family of AC drive. When installed near the drive, the device can reduce potentially destructive reflected wave spikes that can occur with long motor leads and reduces the effect of Common Mode noise.

Catalog Number Explanation

1204		– RWC		– 17 ⁽¹⁾		– A	
<i>First Position</i>		<i>Second Position</i>		<i>Third Position</i>		<i>Fourth Position</i>	
Description		Type		Current Rating		Mounting Config.	
Bulletin Number	Letter	Description	Code	Rating	Letter	Mounting	
	RWC	Reflected Wave Reduction Device IP20 (NEMA Type 1)	17	17.5 Amps at 380-480V, 12 Amps at 575-600V	A	Book Style ⁽²⁾	

⁽¹⁾ Consult factory for 240V applications.

⁽²⁾ Chassis is rated IP20 (NEMA Type 1) for Book Style mounting.

Specifications

Input Power	380-600VAC, Three-Phase
Drive Carrier Frequency	2 kHz Recommended (used for most applications) Important: 6kHz Absolute Maximum – Refer to Chart below and page 4 for application restrictions.
Ambient Temperature	0-50 Degrees C (32-122 Degrees F)
Humidity	5-95% Non-Condensing
Atmosphere	Atmosphere should not contain hazardous (volatile) dust, vapor, gas or liquid. IP20 (NEMA Type 1) = Book Style Mount IP00 (Open Chassis) = Horizontal Mount
Current Rating	17.5 Amperes at 480 Volts (12.0 Amperes at 600 Volts)
Vibration	1.0 G Operational
Agency Certification	
Altitude Derating	Above 1000 meters (3300 feet) derate at 6% of RWC rated amperes per 1000 meters (3300 feet) elevation to 4000 meters (13200 feet) maximum.
Heat Dissipation	Use the cable length and drive carrier frequency to find the approximate RWC losses for your system. Vertical movement inside the loss band will be dependent on exact cable type and motor load.

Total Watts Loss

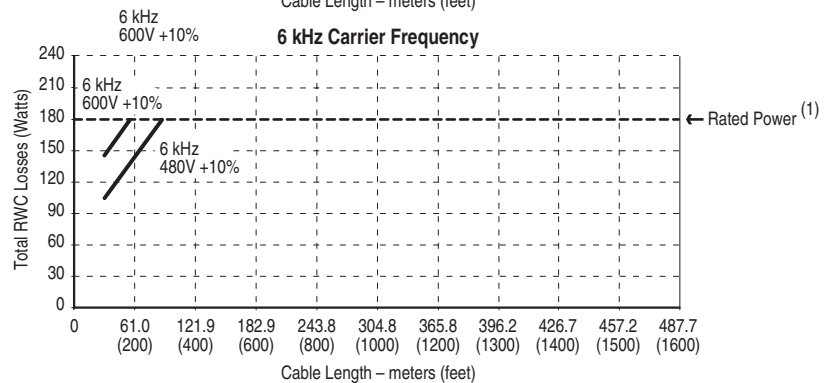
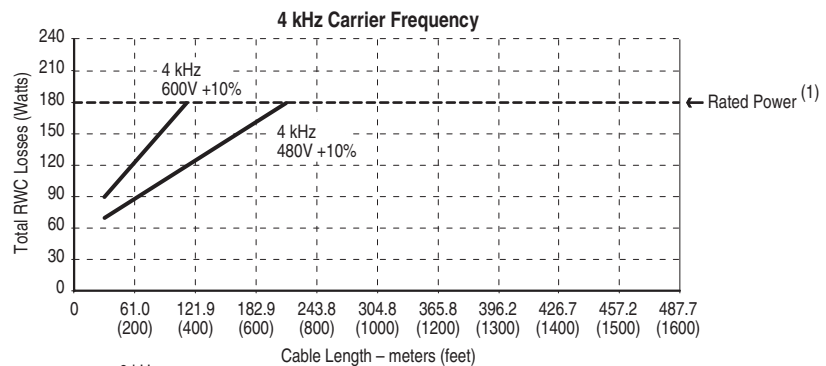
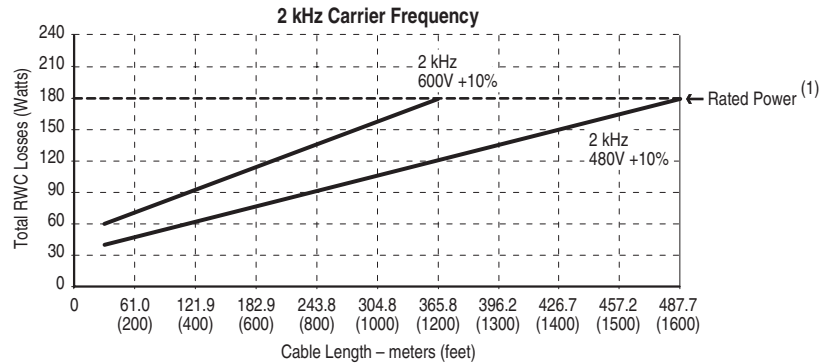

(1) Do not run unit above Rated Power.

Nameplate Information

The nameplate is located on the front of the unit. In addition, a manufacturing date is stamped on the bottom of the unit.

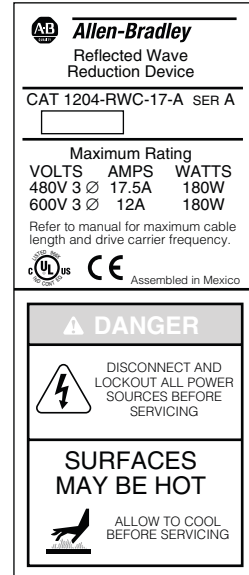

Dimensions

Dimensions are in millimeters and (inches).
Shipping weight = 4.1 kg (9.0 lb)

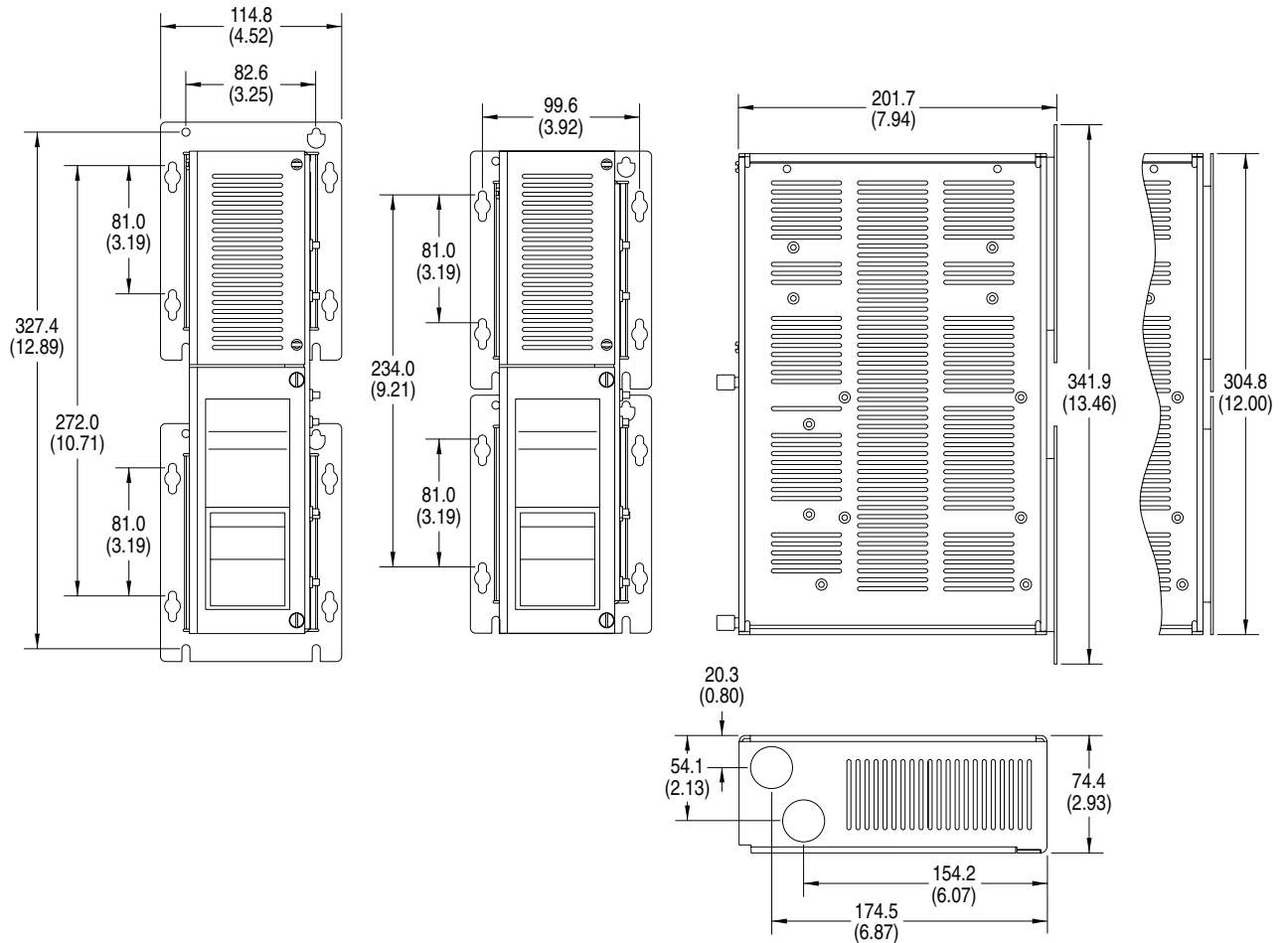

Determining the Maximum Cable Length for your System

The following tables will help you determine the maximum cable length for your system.

1336 Plus/Plus II/Impact/1336T 3.7-7.5 kW (5-10 HP) and 3.7-7.5 kW (5-10 HP) Motors

Table A: 380-400V Drives

Volts at Motor	Motor Insulation ⁽¹⁾	Drive Carrier Frequency	Maximum Cable Length in meters (feet)				1204-RWC Maximum Cable Length ⁽⁴⁾
			Shielded ⁽²⁾		Unshielded		
			Nominal Line Voltage	High Line Voltage ⁽³⁾	Nominal Line Voltage	High Line Voltage ⁽³⁾	
1000	Type A	2 kHz	488 (1600)	488 (1600)	488 (1600)	425 (1400)	488 (1600) 244 (800) 75 (250)
		4 kHz	244 (800)	244 (800)	244 (800)	244 (800)	
		6 kHz	76 (250)	76 (250)	76 (250)	76 (250)	
1200	Type B	2 kHz	488 (1600)	488 (1600)	488 (1600)	488 (1600)	
		4 kHz	244 (800)	244 (800)	244 (800)	244 (800)	
		6 kHz	76 (250)	76 (250)	76 (250)	76 (250)	
1600	1329 R/L	2 kHz	488 (1600)	488 (1600)	488 (1600)	488 (1600)	
		4 kHz	244 (800)	244 (800)	244 (800)	244 (800)	
		6 kHz	76 (250)	76 (250)	76 (250)	76 (250)	

Table B: 480V Drives

Volts at Motor	Motor Insulation ⁽¹⁾	Drive Carrier Frequency	Maximum Cable Length in meters (feet)				1204-RWC Maximum Cable Length ⁽⁴⁾
			Shielded ⁽²⁾		Unshielded		
			Nominal Line Voltage	High Line Voltage ⁽³⁾	Nominal Line Voltage	High Line Voltage ⁽³⁾	
1000	Type A	2 kHz	488 (1600)	305 (1000)	182 (600)	60 (200)	488 (1600) 244 (800) 75 (250)
		4 kHz	244 (800)	244 (800)	182 (600)	60 (200)	
		6 kHz	76 (250)	75 (250)	76 (250)	45 (150)	
1200	Type B	2 kHz	488 (1600)	488 (1600)	488 (1600)	488 (1600)	
		4 kHz	244 (800)	244 (800)	244 (800)	244 (800)	
		6 kHz	76 (250)	76 (250)	76 (250)	76 (250)	
1600	1329 R/L	2 kHz	488 (1600)	488 (1600)	488 (1600)	488 (1600)	
		4 kHz	244 (800)	244 (800)	244 (800)	244 (800)	
		6 kHz	76 (250)	76 (250)	76 (250)	76 (250)	

Table C: 600V Drives

Volts at Motor	Motor Insulation ⁽¹⁾	Drive Carrier Frequency	Maximum Cable Length in meters (feet)				1204-RWC Maximum Cable Length ⁽⁴⁾
			Shielded ⁽²⁾		Unshielded		
			Nominal Line Voltage	High Line Voltage ⁽³⁾	Nominal Line Voltage	High Line Voltage ⁽³⁾	
1000	Type A	2 kHz	90 (300)	⁽⁶⁾	⁽⁶⁾	⁽⁶⁾	365 (1200) 120 (400) 60 (200)
		4 kHz	90 (300)	⁽⁶⁾	⁽⁶⁾	⁽⁶⁾	
		6 kHz	60 (200)	⁽⁶⁾	⁽⁶⁾	⁽⁶⁾	
1200	Type B	2 kHz	365 (1200)	305 (1000)	182 (600)	60 (200)	
		4 kHz	120 (400)	120 (400)	120 (400)	60 (200)	
		6 kHz	60 (200)	60 (200)	60 (200)	60 (200)	
1600 ⁽⁵⁾	1329 R/L	2 kHz	365 (1200)	365 (1200)	365 (1200)	365 (1200)	
		4 kHz	120 (400)	120 (400)	120 (400)	120 (400)	
		6 kHz	60 (200)	60 (200)	60 (200)	60 (200)	

(1) Type A = No phase paper or misplaced phase paper, lower quality insulation systems, corona inception voltages between 850 and 1000 volts.
 Type B = Properly placed phase paper, medium quality insulation systems, corona inception voltages between 1000 and 1200 volts.
 1329 R/L = "Control Matched" motors for use with Allen-Bradley drives, premium grade insulation system, typical corona inception voltage is 1600 volts.

(2) Includes wire run in conduit.

(3) High line condition is defined at rated input system voltage +10% with a fully rated motor condition.

(4) Maximum cable length is restricted by power dissipation within the 1204-RWC package at 40°C (104°F) ambient under rated load.

(5) When used on 600V systems, 1329 R/L motors have a corona inception voltage rating of approximately 1850V.

(6) Not recommended with 1204-RWC.

Call factory for advice on using the 1204-RWC with drives other than the 1336 family of AC drive.

Installation

The following steps will guide you through mounting the Reflected Wave Reduction Device.



ATTENTION: To avoid a shock hazard, ensure that all power to the drive has been removed before proceeding. In addition, wait 3 minutes for the DC bus to discharge.



ATTENTION: Enclosure surfaces may be hot and can cause severe burns. Install in a location that minimizes accidental contact.

Mounting

1. Assure that all power has been removed from the drive.
2. Attach the mounting brackets to the back of the chassis using the eight screws provided. The brackets can be positioned either flush or extended as shown below.

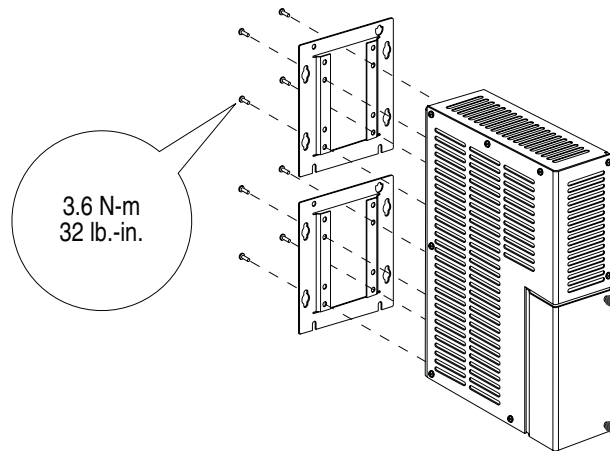

Brackets Extended

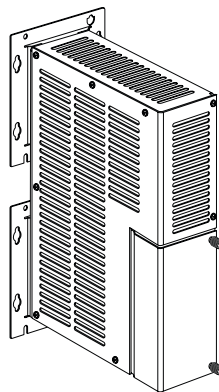

Brackets Flush

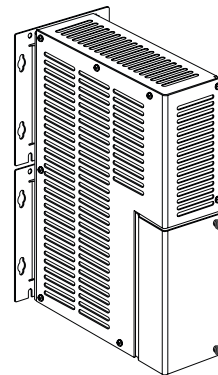

3. Mount the device on a vertical metal surface and oriented so the wiring knockouts are on the bottom – the device must be mounted within 3.0 meters (10 feet) of the drive.

Important: To assure proper heat dissipation, minimum clearances must be maintained as shown below.

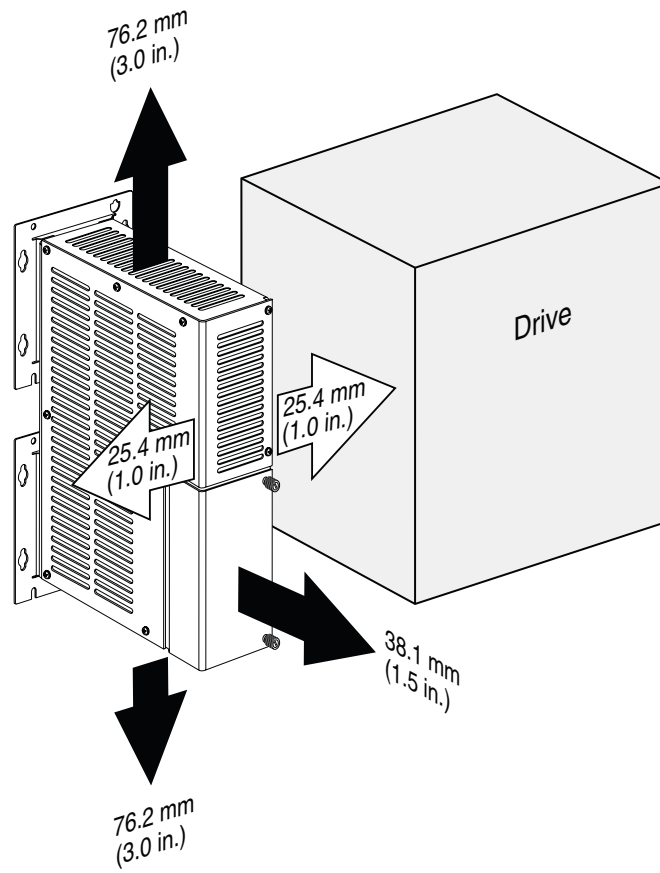

Wiring

4. Wire the device as indicated below. The maximum and minimum wire size accepted by the RWC terminal block is 4.0 and 0.75 mm² (10 and 18 AWG). Use copper wire only with a minimum temperature rating of 75 degrees C. Maximum torque is 1.81 N-m (16 lb.-in.).

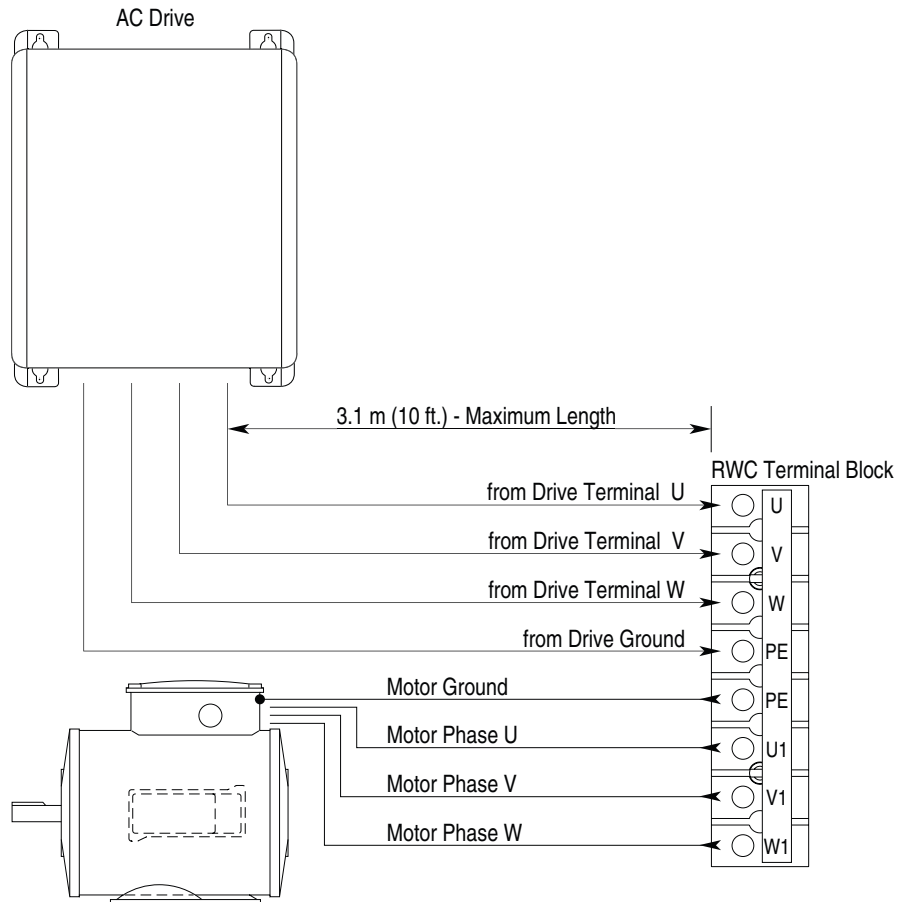

Grounding

- Follow the recommended grounding practices provided in your drive User Manual. The following diagram shows an example of system grounding practices.



ATTENTION: National Codes and standards (NEC, VDE, BSI, etc.) and local codes outline provisions for safely installing electrical equipment. Installation must comply with specifications regarding wire types, conductor sizes, branch circuit protection and disconnect devices. Failure to do so may result in personal injury and/or equipment damage.

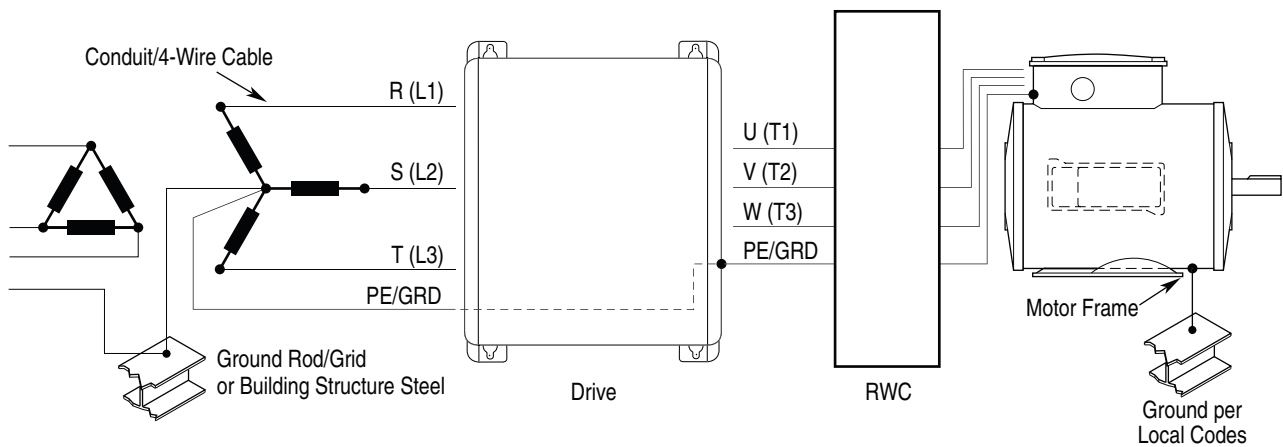

Drive Programming

- The recommended drive carrier frequency for optimal RWC performance is 2 kHz. The maximum carrier frequency allowed is 6 kHz. If the drive default is higher than this maximum, the drive must be reprogrammed. Refer also to the Maximum Cable Length tables on page 4 for further information.
- Carefully check that motor rotation is in the desired direction.

www.rockwellautomation.com

Corporate Headquarters

Rockwell Automation, 777 East Wisconsin Avenue, Suite 1400, Milwaukee, WI, 53202-5302 USA, Tel: (1) 414.212.5200, Fax: (1) 414.212.5201

Headquarters for Allen-Bradley Products, Rockwell Software Products and Global Manufacturing Solutions

Americas: Rockwell Automation, 1201 South Second Street, Milwaukee, WI 53204-2496 USA, Tel: (1) 414.382.2000, Fax: (1) 414.382.4444
 Europe: Rockwell Automation SA/NV, Vorstlaan/Boulevard du Souverain 36-BP 3A/B, 1170 Brussels, Belgium, Tel: (32) 2 663 0600, Fax: (32) 2 663 0640
 Asia Pacific: Rockwell Automation, 27/F Citicorp Centre, 18 Whitfield Road, Causeway Bay, Hong Kong, Tel: (852) 2887 4788, Fax: (852) 2508 1846

Headquarters for Dodge and Reliance Electric Products

Americas: Rockwell Automation, 6040 Ponders Court, Greenville, SC 29615-4617 USA, Tel: (1) 864.297.4800, Fax: (1) 864.281.2433
 Europe: Rockwell Automation, Brühlstraße 22, D-74834 Elztal-Dallau, Germany, Tel: (49) 6261 9410, Fax: (49) 6261 1774
 Asia Pacific: Rockwell Automation, 55 Newton Road, #11-01/02 Revenue House, Singapore 307987, Tel: (65) 351 6723, Fax: (65) 355 1733

U.S. Allen-Bradley Drives Technical Support

Tel: (1) 262.512.8176, Fax: (1) 262.512.2222, Email: support@drives.ra.rockwell.com, Online: www.ab.com/support/abdrives