



BULLETIN 160 LOW PROFILE DRIVE

IMPORTANT: This instruction sheet contains information for the installation of the Bulletin 160 Low Profile Drive. The User Manual for the Bulletin 160 SSC Variable Speed Drive (Series C) should be used as a supplement to this sheet.

⚠ ATTENTION: To guard against electrical shock, disconnect from power source before installing or servicing.

⚠ ATTENTION: Do not touch drive surfaces. Temperatures are hot enough to cause severe burns.

⚠ ATTENTION: After system installation, remove the debris label from unit. Failure to remove this label may result in overheating or nuisance tripping.

Choose an installation method:

- Install on 35mm DIN Rail.
- Install with screws. Recommended screw size is listed in the table below.

Description	Metric	English
Minimum Panel Thickness (14 GA)	1.9 mm	0.0747 in.
Mounting Base Screws	M4 x 0.7	# 8-32
Mounting Torque	1.13 – 1.56 Nm	10 – 14 lb-in.

Mount bottom screws through mounting holes in fan bracket.

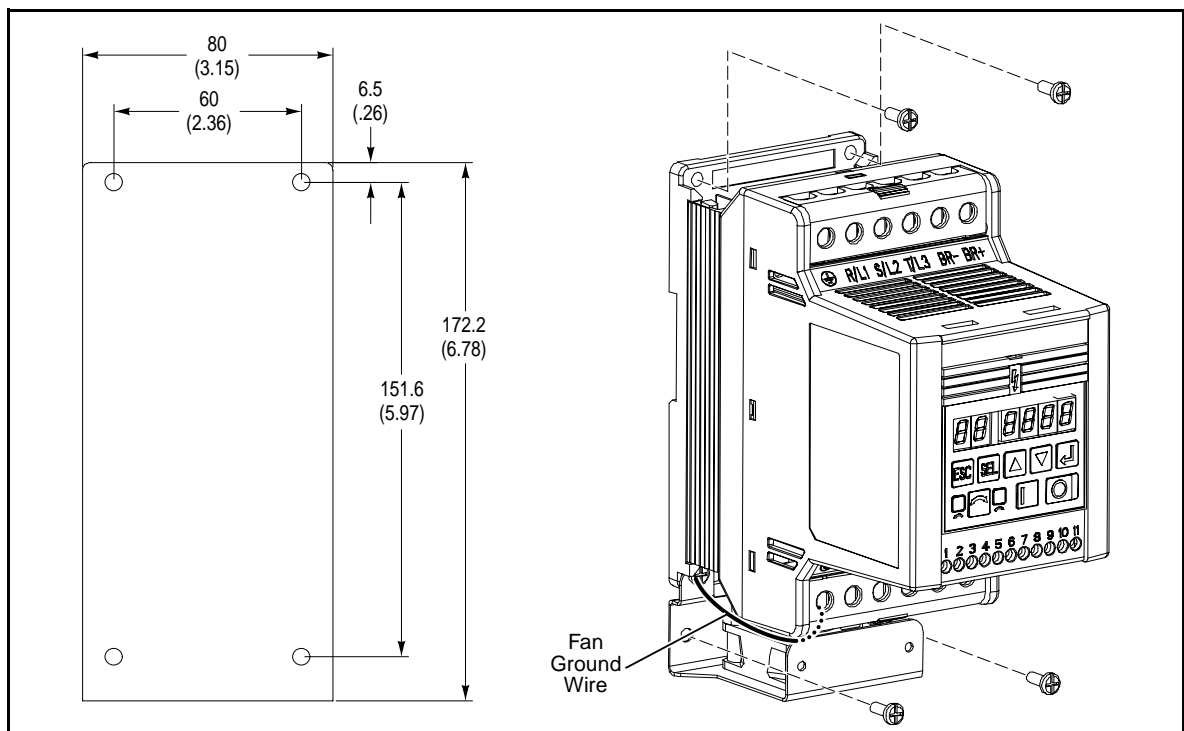

Maintain 12.5 mm (0.5 in.) clearance at the top, bottom, and front of drive. Provide a minimum of 8.5 mm (0.33 in.) between units.

The 160-L requires grounding just as all 160s.

The fan bracket is wired to the load side ground terminal block. It is the User's responsibility to wire the system ground.

The ground terminal on the line side of the 160-L (top) can accept one or two 12 gage wires. The ground terminal on the load side (bottom) of the 160-L can accept one 12 gage wire (due to wire from fan bracket).

All dimensions are in millimeters and (inches), all weights are in kilograms and (pounds).

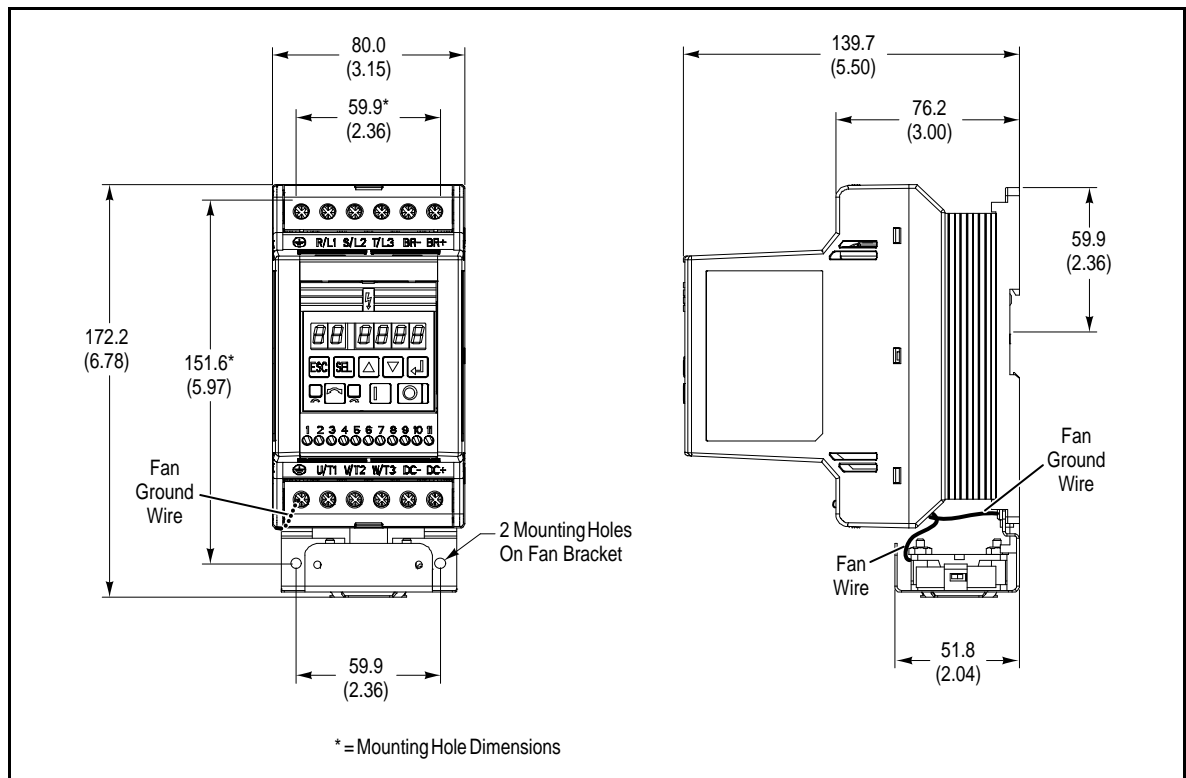

Drive Dimensions and Weights

200-240 VAC – 3-Phase				
Drive	H	W	D	Weight
160-AA12L	172.2 (6.78)	80 (3.15)	140 (5.50)	0.84 (1.85)
380-460 VAC – 3-Phase				
Drive	H	W	D	Weight
160-BA06L	172.2 (6.78)	80 (3.15)	140 (5.50)	0.84 (1.85)

The following curves show the output ratings of a Low Profile Drive based on input voltage and duty cycle. Duty cycle is calculated based on a 20 second on-time.
(For example: 25% duty cycle = 20 second on time, 60 second off time).

The heatsink of the 160-L is smaller than the heatsink of the standard Series C 160. The 160-L can not dissipate heat as effectively as the standard Series C 160.

The purpose of these derating curves is to show how much current the 160-L may carry.

The maximum on time that can be used without 100% duty cycle derating is 20 seconds. To illustrate how the charts function, consider the following examples:

1. 160-L is on for 1 second and off for 3 seconds, the duty cycle is 25%.
2. 160-L is on for 20 seconds and off for 20 seconds, the duty cycle is 50%.
3. 160-L is on for 40 seconds and off for 120 seconds, the duty cycle is 100%.

IMPORTANT: Since the on time in example 3 exceeds 20 seconds, 100% duty cycle derating must be used regardless of the off time.

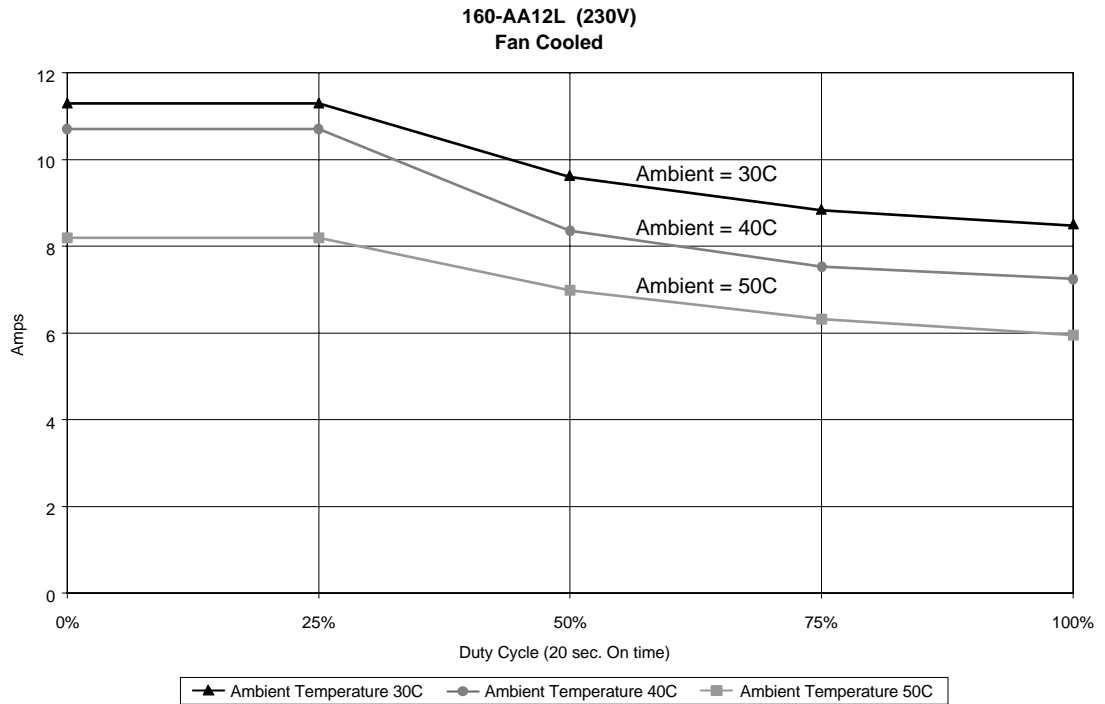

**160-BA06L (460V)
Fan Cooled**

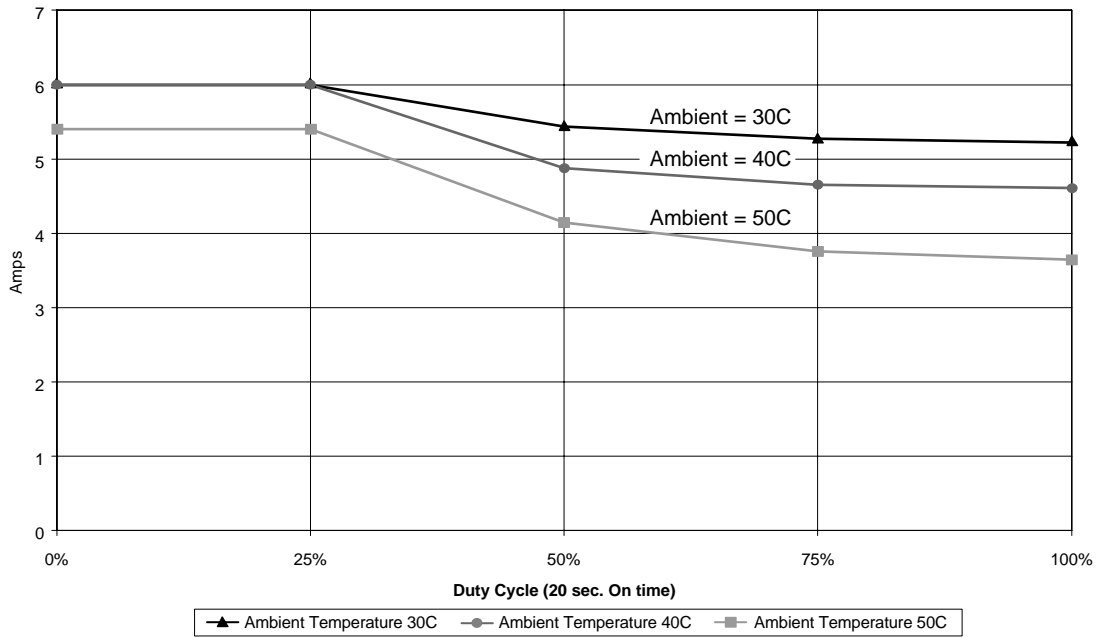

Reach us now at www.rockwellautomation.com

Wherever you need us, Rockwell Automation brings together leading brands in industrial automation including Allen-Bradley controls, Reliance Electric power transmission products, Dodge mechanical power transmission components, and Rockwell Software. Rockwell Automation's unique, flexible approach to helping customers achieve a competitive advantage is supported by thousands of authorized partners, distributors and system integrators around the world.

Americas Headquarters, 1201 South Second Street, Milwaukee, WI 53204, USA, Tel: (1) 414 382-2000, Fax: (1) 414 382-4444
European Headquarters SA/NV, avenue Herrmann Debroux, 46, 1160 Brussels, Belgium, Tel: (32) 2 663 06 00, Fax: (32) 2 663 06 40
Asia Pacific Headquarters, 27/F Citicorp Centre, 18 Whitfield Road, Causeway Bay, Hong Kong, Tel: (852) 2887 4788, Fax: (852) 2508 1846



**Rockwell
Automation**