







- General Information** Quick Selection Guide ..... page R9–2
- DeviceNet Sensors**
  - RightSight™ DeviceNet ..... page R9–4
  - SmartSight™ 9000 DeviceNet ..... page R9–8
  - Inductive Proximity
    - DeviceNet ..... page R9–12
  - Limit Switch DeviceNet ..... page R9–14
  - Encoder DeviceNet ..... page R9–16
  - DeviceLink™ ..... page R9–18
- Indexes**
  - Catalog Number Index ..... page R11–1
  - Comprehensive Product Index ..... page R12–1

## Quick Selection Guide

<p><b>Specifications</b></p>	 <p><b>RightSight™</b> Photoelectric Sensor</p>	 <p><b>SmartSight™ 9000</b> Photoelectric Sensor</p>	 <p><b>871TM</b> Inductive Proximity Sensor</p>
<p><b>Features</b></p>	<ul style="list-style-type: none"> <li>• DeviceNet Network compatibility</li> <li>• Patented 18mm housing design with 1200psi washdown rating</li> <li>• Selectable COS/Strobe</li> <li>• Advanced diagnostics, counter, and timers</li> </ul>	<ul style="list-style-type: none"> <li>• DeviceNet Network compatibility</li> <li>• Harsh duty 30mm housing</li> <li>• 1200psi washdown</li> <li>• Advanced features such as teach, selectable COS/Strobe, counter, timers and diagnostics</li> </ul>	<ul style="list-style-type: none"> <li>• DeviceNet Network compatibility, stainless steel face and barrel, 1200psi washdown rated, standard mounting, discrete or analog output, timing options, advanced diagnostics</li> </ul>
<p><b>Output Type</b></p>	<ul style="list-style-type: none"> <li>• DeviceNet</li> </ul>	<ul style="list-style-type: none"> <li>• DeviceNet</li> </ul>	<ul style="list-style-type: none"> <li>• DeviceNet</li> </ul>
<p><b>Connections</b></p>	<ul style="list-style-type: none"> <li>• 5-pin DC micro QD</li> </ul>	<ul style="list-style-type: none"> <li>• 5-pin DC micro QD</li> <li>• 5-pin mini QD</li> <li>• 2m cable</li> </ul>	<ul style="list-style-type: none"> <li>• 5-pin DC micro QD</li> <li>• 5-pin mini QD</li> <li>• 2m CPE cable</li> </ul>
<p><b>Available Models</b></p>	<ul style="list-style-type: none"> <li>• Polarized Retroreflective . . . . . R9-6</li> <li>• Standard Diffuse . . . . . R9-6</li> <li>• Sharp Cutoff Diffuse . . . . . R9-6</li> <li>• Background Suppression . . . . . R9-6</li> <li>• Infrared Fiber Optic . . . . . R9-7</li> <li>• Transmitted Beam . . . . . R9-7</li> </ul>	<ul style="list-style-type: none"> <li>• Retroreflective . . . . . page R9-10</li> <li>• Polarized Retroreflective . . . . . page R9-10</li> <li>• ClearSight™ . . . . . page R9-10</li> <li>• Standard Diffuse . . . . . page R9-11</li> <li>• Infrared Glass Fiber Optic . . . . . page R9-11</li> <li>• Visible Red Glass Fiber Optic . . . . . page R9-11</li> <li>• Transmitted Beam . . . . . page R9-11</li> </ul>	<ul style="list-style-type: none"> <li>• 18mm shielded . . . . . R9-12</li> <li>• 18mm unshielded . . . . . R9-12</li> <li>• 30mm shielded . . . . . R9-12</li> <li>• 30mm unshielded . . . . . R9-12</li> </ul>
<p><b>Additional Info</b></p>	<ul style="list-style-type: none"> <li>• See page R9-4</li> </ul>	<ul style="list-style-type: none"> <li>• See page R9-8</li> </ul>	<ul style="list-style-type: none"> <li>• See page R9-12</li> </ul>

<p><b>Specifications</b></p>	 <p><b>802DN</b> Limit Switch</p>	 <p><b>842D</b> Encoder</p>	 <p><b>DeviceLink™</b> Single Point I/O</p>
<p><b>Features</b></p>		<ul style="list-style-type: none"> <li>• DeviceNet Network compatibility, advanced diagnostics</li> </ul>	<ul style="list-style-type: none"> <li>• DeviceNet Network compatibility, strobing only, 1200psi washdown rated, configurable debounce filtering</li> </ul>
<p><b>Output Type</b></p>	<ul style="list-style-type: none"> <li>• DeviceNet</li> </ul>	<ul style="list-style-type: none"> <li>• DeviceNet</li> </ul>	<ul style="list-style-type: none"> <li>• DeviceNet</li> </ul>
<p><b>Connections</b></p>	<ul style="list-style-type: none"> <li>• 5-pin DC micro QD</li> <li>• 5-pin mini QD</li> <li>• 2m CPE cable</li> </ul>	<ul style="list-style-type: none"> <li>• 5-pin DC micro QD</li> </ul>	<ul style="list-style-type: none"> <li>• 5-pin DC micro QD</li> <li>• 5-pin mini QD</li> <li>• CPE cable</li> </ul>
<p><b>Available Models</b></p>	<ul style="list-style-type: none"> <li>• Limit Switch without lever . . . . . R9-14</li> <li>• Limit Switch with wide belt roller . . . . . R9-14</li> </ul>	<ul style="list-style-type: none"> <li>• 26-bit absolute multi-turn . . . . . R9-16</li> </ul>	<ul style="list-style-type: none"> <li>• Mini DeviceNet connection . . . . . R9-18</li> <li>• Micro DeviceNet connection . . . . . R9-18</li> <li>• Cable DeviceNet connection . . . . . R9-18</li> </ul>
<p><b>Additional Info</b></p>	<ul style="list-style-type: none"> <li>• See page R9-14</li> </ul>	<ul style="list-style-type: none"> <li>• See page R9-16</li> </ul>	<ul style="list-style-type: none"> <li>• See page R9-18</li> </ul>



**Description**

Rockwell Automation/Allen-Bradley DeviceNet sensors interface directly to this industry standard plant floor network without the need for additional I/O blocks or adaptors. In addition to the standard On/Off indication, DeviceNet compatible sensors provide advanced logic and diagnostic functions not available in competitive DeviceNet models. Logic functions include counters, timers and motion detection while the diagnostics warn of unstable application characteristics. For example, the 871TM DeviceNet proximity sensor will produce a diagnostic output when the target is too close to the sensor face or at the outside edge of the sensing range. Further, Allen-Bradley DeviceNet sensors may be configured for either strobing or change-of-state (COS) operating modes, normally open or normally closed outputs (light operate or dark operate for photoelectric sensors) and discrete or analog output. This flexibility allows a single sensor to be configured for a variety of applications.

DeviceNet sensors may be assigned any node address between 0 and 63. While a sensor's baud rate is determined automatically as it is added to the network (autobaud), it may also be manually programmed to 125, 250, or 500kb/s. Configuration of all network and sensor parameters can be done over the network with Rockwell

Software's RSNetWorx package and for field configuration or diagnostics, the DeviceView Hand-Held Configurator (2707-DNC) is available.

For applications requiring many sensors and simple On/Off indication only, Allen-Bradley DeviceLink is the ideal solution. Serving as a gateway between a standard, off-the-shelf sensing device and the DeviceNet network, DeviceLink is compatible with any 2- or 3-wire 24V sensor with open collector sourcing output, any device with relay contacts or any mechanical sensing device. Each DeviceLink acts as a single node on the network.

**Features**

- Direct interface to DeviceNet network
- Strobing and COS protocols
- Autobaud detect
- Operating parameters configurable over the network
- Advanced diagnostics
- Integral timing and counting functions
- Mini, micro, or cable connection options

**DeviceNet Sensors**

RightSight™ DeviceNet . . . . page R9-4  
 SmartSight™ 9000 . . . . . page R9-8  
 Inductive Proximity DeviceNet . . . . . page R9-12  
 Limit Switch DeviceNet . . . . . page R9-14  
 Encoder DeviceNet . . . . . page R9-16  
 DeviceLink™ . . . . . page R9-18



DeviceNet RightSight



**Description**

RightSight DeviceNet photoelectric sensors interface directly to this industry standard plant floor network without the need for additional I/O blocks or adaptors.

**Features**

- Compact RightSight housing
- 1200psi (8270kPa) washdown rating
- Direct interface to DeviceNet network
- Strobging and COS protocols
- On Delay and Off Delay/One-Shot timers
- Adjustable counter with output
- Adjustable motion detection
- Dual margin threshold diagnostics
- Autobaud

**Sensing Modes**

- Dimensions . . . . . page R9–5
- Polarized Retroreflective . . . page R9–6
- Standard Diffuse . . . . . page R9–6
- Sharp Cutoff Diffuse . . . . . page R9–6
- Background Suppression . . . page R9–6
- Infrared Glass Fiber Optic . . . page R9–7
- Transmitted Beam . . . . . page R9–7

**General Specifications**

<b>Network Interface</b>	DeviceNet
<b>Protocol</b>	Selectable Change-of-state (COS) and Strobing
<b>Operating Mode</b>	Selectable light/dark operate
<b>Autobaud Detect</b>	Selectable On/Off
<b>Communication Rate</b>	Selectable 125kb/s, 250kb/s, 500kb/s or autobaud
<b>Supported Node Address</b>	Selectable 0 to 63
<b>Timer</b>	On Delay and Off Delay/One-Shot (0 to 65,535ms, 1 or 10ms time base)
<b>Counter</b>	Adjustable with output bit (0 to 65,535 counts)
<b>Motion Detect</b>	Adjustable with output bit (0 to 65,535ms, 1ms time base)
<b>Margin Diagnostic</b>	Selectable with dual thresholds (0.7 to 1.5 and 0.7 to 2.5)
<b>Margin Diagnostic Type</b>	Selectable static or dynamic
<b>Output Protection</b>	False pulse, reverse polarity, overload, short circuit
<b>Supply Voltage</b>	24V DC
<b>Current Consumption</b>	60mA
<b>Housing Material</b>	Mindel
<b>Lens Material</b>	Acrylic
<b>Cover Material</b>	Udel
<b>LED Indicators</b>	See table below
<b>QD Construction</b>	5-pin micro QD
<b>Supplied Accessories</b>	18mm mounting nut
<b>Optional Accessories</b>	Rockwell Software RSNetWork for configuration
<b>Operating Environment</b>	NEMA 4X, 6P, IP67 (IEC529) 1200psi (8270kPa) washdown
<b>Vibration</b>	10–55Hz, 1mm amplitude, Meets or exceeds IEC 60947–5–2
<b>Shock</b>	30G with 1ms pulse duration, Meets or exceeds IEC 60947–5–2
<b>Operating Temperature</b>	–25°C to +70°C (–13°F to +158°F) @ 24V DC
<b>Relative Humidity</b>	5% to 95%
<b>Approvals</b>	UL listed, CSA certified, and CE marked for all applicable directives

Label	Color	State	Status
Output	Yellow	On	Target detected
		Off	Margin < 2.0
Margin	Orange	On	Margin > 2.0
		Off	Sensor not powered
Status	Red/Green	Green On Steady	Sensor active and allocated by a Master
		Green Flashing	Sensor active but not allocated by a Master
		Red Flashing	Minor correctable fault (baud rate)
		Red On Steady	Major fault (possible duplicate address)

**I/O Data Byte 1**

	Bit 0	Bit 1	Bit 2	Bit 3	Bit 4	Bit 5	Bit 6	Bit 7
	<b>Output</b>	<b>Diagnostic</b>	<b>Margin 1</b>	<b>Margin 2</b>	<b>Motion Detect</b>	<b>Counter Output</b>	<b>Not Used</b>	<b>Not Used</b>
0	OFF	OK	OK	OK	Motion	Less Than Preset		
1	ON	ALARM	Margin Unstable	Margin Unstable	No Motion	Preset Reached		

**General Specifications (continued)**

**RightSight Nonadjustable Sensor**

**RightSight Adjustable Sensor**

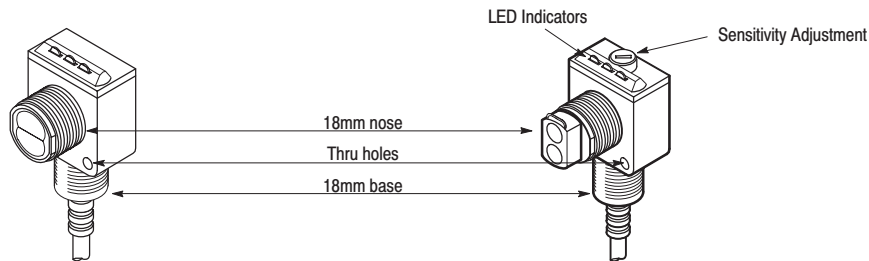

**Dimensions—mm (inches)**

**DeviceNet Models**

**DC Light Source Models**

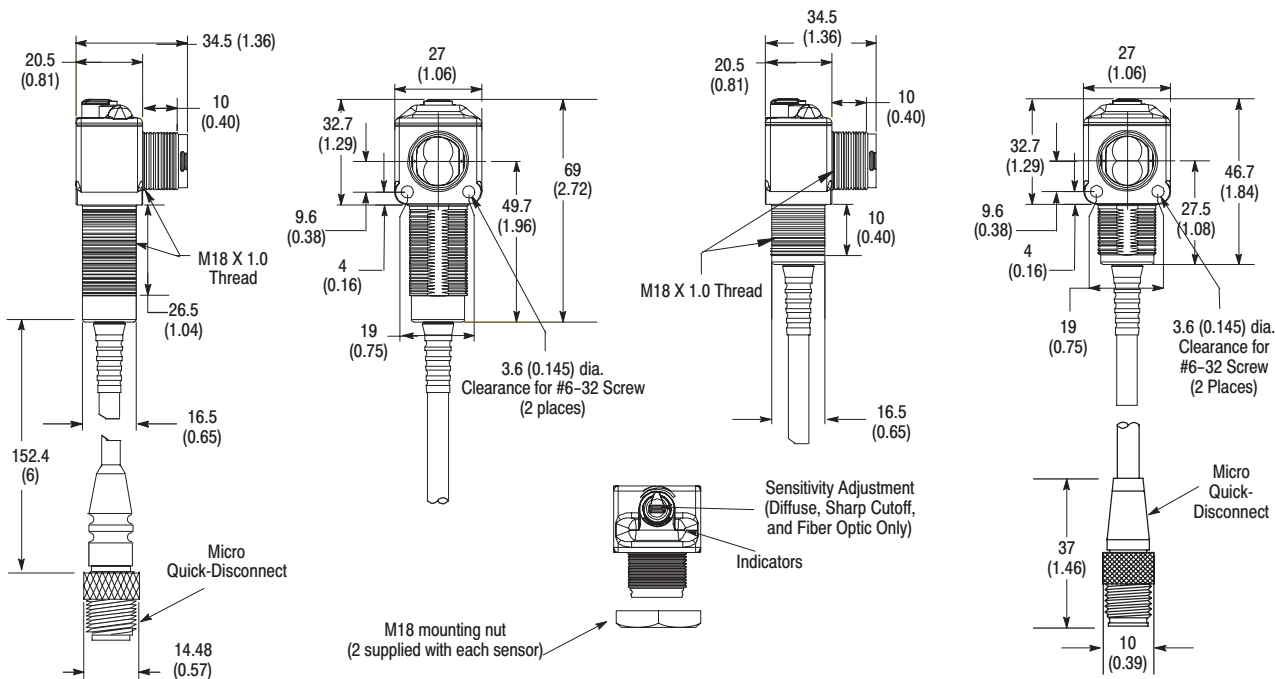

Product Selection

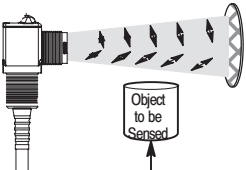
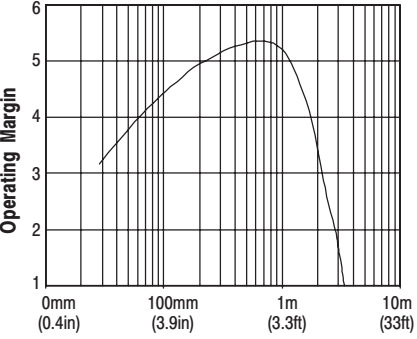
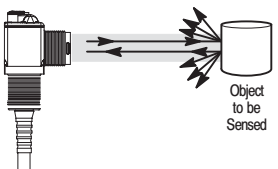
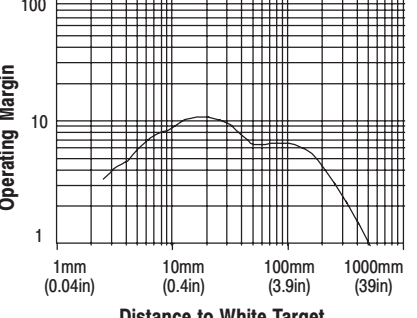
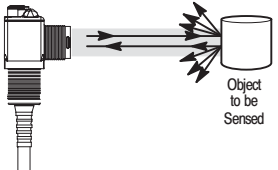
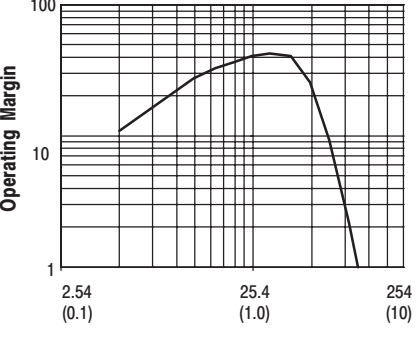
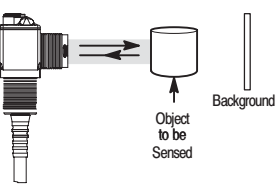
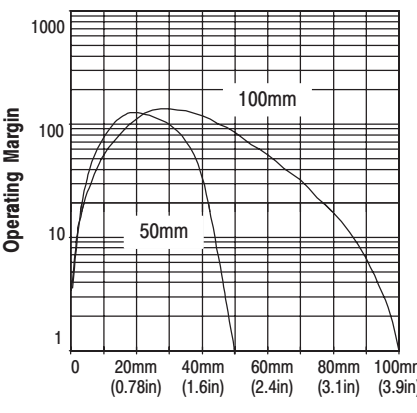
Sensing Mode	Min/Max Sensing Distance	Connection Type	Catalog Number	Typical Response Curve
 <p>Polarized Retroreflective</p>	<p>25mm (1.0in)/ 3m (9.8ft)</p>		<p>42EF-P2LDB-F5</p>	 <p>Distance to 76mm Reflector—92-39</p>
 <p>Standard Diffuse</p>	<p>3mm (0.12in)/ 500mm (20in)</p>		<p>42EF-D1LDAK-F5</p>	 <p>Distance to White Target</p>
 <p>Sharp Cutoff Diffuse</p>	<p>&lt;130mm (5in) 40mm (1.5in) @ 30x margin</p>	<p>5-pin DC micro QD</p>	<p>42EF-S1LDA-F5</p>	 <p>Distance to White Target—mm (in)</p>
 <p>Background Suppression</p>	<p>3mm (0.12in)/ 50mm (2in)</p> <p>3mm (0.12in)/ 100mm (4in)</p>		<p>42EF-B1LDBC-F5</p> <p>42EF-B1LDBE-F5</p>	 <p>Distance to White Target</p>

**Product Selection (continued)**

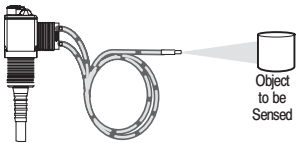
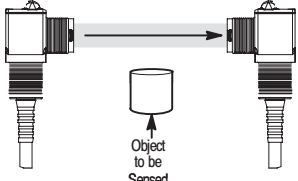
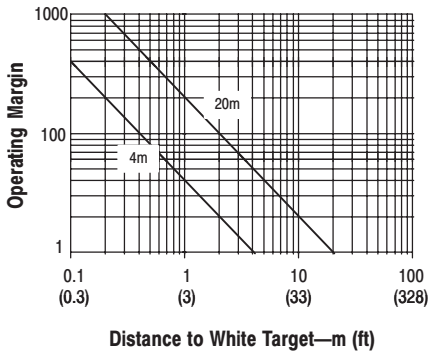
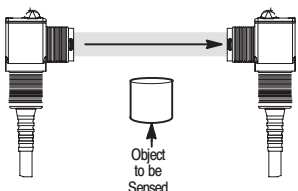
Sensing Mode	Min/Max Sensing Distance	Connection Type	Catalog Number	Typical Response Curve
 Infrared Glass Fiber Optic	Depends on fiber optic cable selected	5-pin DC micro QD	42EF-G1LDA-F5	Depends on fiber optic cable selected
 Transmitted Beam Light Source	See receiver models below	5-pin DC micro QD	42EF-E1EDZB-F5	
		4-pin DC micro QD	42EF-E1EZB-F4	
		2m 300V cable	42EF-E1EZB-A2	
 Transmitted Beam Receiver	25mm (1in)/ 4m (13ft)	5-pin DC micro QD	42EF-R9LDBV-F5	
	25mm (1in)/ 20m (60ft)		42EF-R9LDB-F5	

**Accessories**

Description	Catalog Number
Reflector, 76mm (3in) Diameter with Center Mount Hole	92-39
Reflector, 32mm (1.25in) Diameter	92-47
Mounting Bracket Swivel/Tilt	60-2649

For additional mounting brackets and accessories, see page R1-232.



**Operation**

SmartSight photoelectric sensors interface directly to this industry standard plant floor network without the need for additional I/O blocks or adaptors. They combine the benefits of the Series 9000 mechanical and optical package with the DeviceNet bus system.

**General Specifications**

<b>Network Interface</b>	DeviceNet
<b>Messaging</b>	Selectable change-of-state (COS) and strobing
<b>Operating Mode</b>	Selectable light/dark operate
<b>Autobaud Detect</b>	Selectable On/Off
<b>Communication Rate</b>	Selectable 125 kb/s, 250 kb/s, 500 kb/s or autobaud
<b>Supported Node Address</b>	Selectable 0...63—via network or local
<b>Margin Diagnostic</b>	Selectable static or dynamic
<b>Margin Diagnostic Type</b>	Dual thresholds (0.7...1.5 and 0.7...2.0)
<b>Output Protection</b>	Miswire
<b>Supply Voltage</b>	24V DC
<b>Current Consumption</b>	65 mA
<b>Housing Material</b>	Valox™
<b>Lens Material</b>	Acrylic
<b>Gasket Cover Material</b>	Neoprene
<b>LED Indicators</b>	See table on page R9-9
<b>Connection Type</b>	5-pin micro QD, 5-pin mini QD, 2 m drop cable
<b>Supplied Accessories</b>	#129-130 hardware kit, 92-90 reflector (ClearSight version only)
<b>Optional Accessories</b>	Rockwell Software RSNetworkx for configuration
<b>Operating Environment</b>	NEMA 3, 4X, 6P, 12, 13, IP 67 (IEC 529) 1200 psi (8270 kPa) washdown
<b>Vibration</b>	10...55Hz, 1 mm amplitude, meets or exceeds IEC 60947-5-2
<b>Shock</b>	30 g with 1 ms pulse duration, meets or exceeds IEC 60947-5-2
<b>Operating Temperature</b>	-25...+70°C (-13...+158°F)
<b>Relative Humidity</b>	5...95%
<b>Approvals (Ordinary Locations)</b>	UL listed, CSA certified, and CE marked for all applicable directives

**Features**

- Local and remote self-teach operation ❶
- 1200psi washdown rating
- Selectable strobing and/or COS ❶
- Margin diagnostics
- Adjustable motion detect ❶
- ON/OFF time delay ❶
- Adjustable counter with output ❶

**General Information**

I/O Data ..... page R9-9  
 Indicators ..... page R9-9  
 Dimensions ..... page R9-9

**Sensing Modes**

Retroreflective ..... page R9-10  
 Polarized Retroreflective .. page R9-10  
 ClearSight™ ..... page R9-10  
 Standard Diffuse ..... page R9-11  
 Infrared Glass Fiber Optic . page R9-11  
 Visible Red Glass  
 Fiber Optic ..... page R9-11  
 Transmitted Beam ..... page R9-11

❶ Not in transmitted beam models.

### I/O Data

	Bit 0	Bit 1	Bit 2	Bit 3	Bit 4	Bit 5	Bit 6	Bit 7
	<b>Sensor Output</b>	<b>Diagnostic</b>	<b>Diagnostic Margin 2x</b>	<b>Diagnostic Margin 3x</b>	<b>Motion Output</b>	<b>Counter Output</b>	<b>Not Used</b>	<b>Not Used</b>
0	OFF	OK	OK	OK	Motion	Less Than Preset		
1	ON	ALARM	Margin Unstable	Margin Unstable	No Motion	Preset Reached		

### Indicators (refer to illustration)

Label	Color	State	Status
Output	Yellow	ON	Target detected
Margin	Orange	OFF	Margin < 2.0
		ON	Margin > 2.0
Status	Red/Green	OFF	Sensor not powered or auto baud
		Green ON Steady	Sensor active and allocated by master
		Green Flashing	Sensor active but not allocated by master
		Red Flashing	Minor correctable fault (baud rate)
		Red ON Steady	Major fault (possible duplicate address)

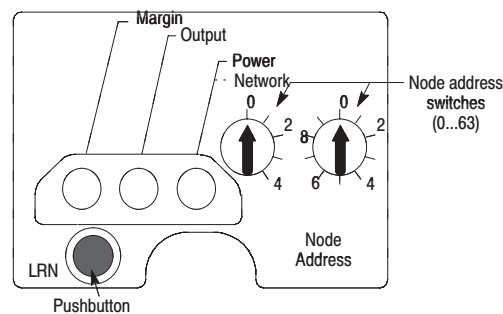

**NOTE:** LED indicators are used during the *Self-Teach* operation of the sensor. Refer to publication 75025-284-01 for complete instructions on using this feature.

### Dimensions—mm (inches)

#### All Models Except Fiber Optic and ClearSight

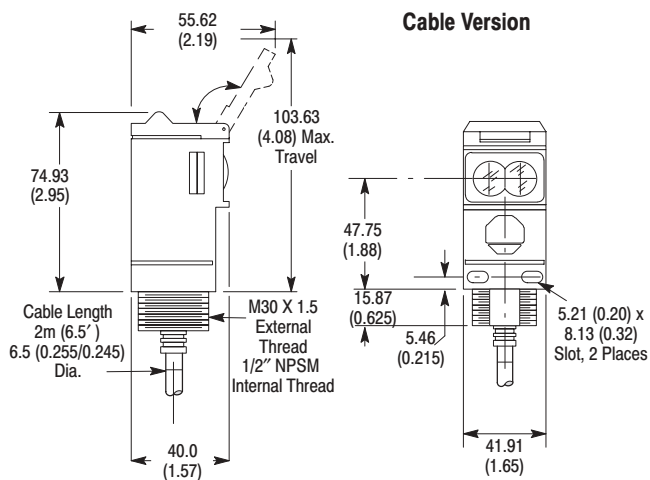

#### Fiber Optic Models

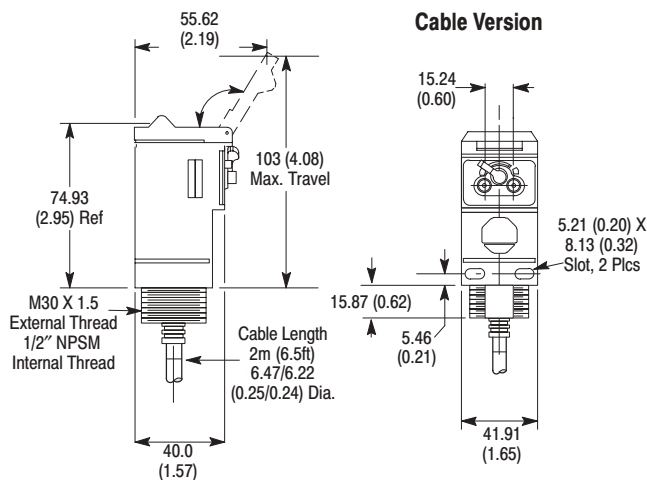

#### Connector Version



#### Thread Size

Micro Style	M12 x 1.1 Keyway
Mini Style	7/8-16 UN 1 Keyway

#### ClearSight Models

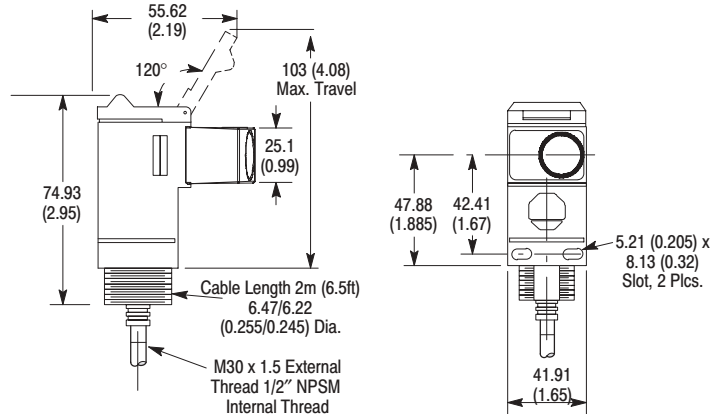

Product Selection

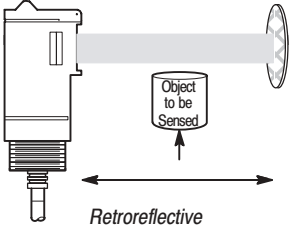
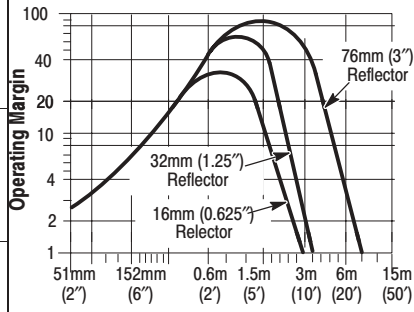
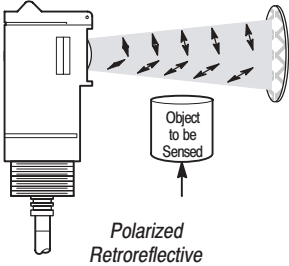
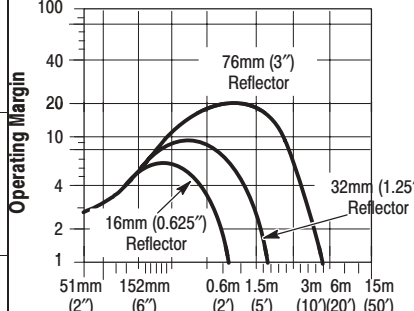
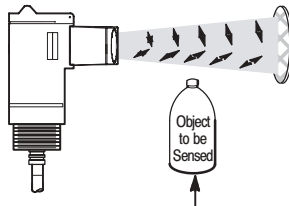
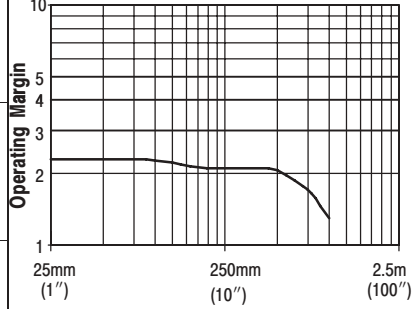
Sensing Mode	Min/Max Sensing Distance	Protocol	Connection Type	Catalog Number	Typical Response Curve
 <p>Retroreflective</p>	51mm (2in) 9.14m (30ft) with 76mm (3") Reflector	Strobging and COS	2m CPE cable	<b>42GNU-9020</b>	
			5-pin DC micro QD	<b>42GNU-9020-QD</b>	
			5-pin mini QD	<b>42GNU-9020-QD1</b>	
 <p>Polarized Retroreflective</p>	51mm (2in) 4.87m (16ft) with 76mm (3") Reflector	Strobging and COS	2m CPE cable	<b>42GNU-9220</b>	
			5-pin DC micro QD	<b>42GNU-9220-QD</b>	
			5-pin mini QD	<b>42GNU-9220-QD1</b>	
 <p>ClearSight™</p>	0mm (0in) to 1.2m (48in)	Strobging and COS	2m CPE cable	<b>42GNC-9220</b>	
			5-pin DC micro QD	<b>42GNC-9220-QD</b>	
			5-pin mini QD	<b>42GNC-9220-QD1</b>	

**Product Selection (continued)**

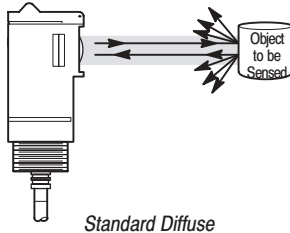
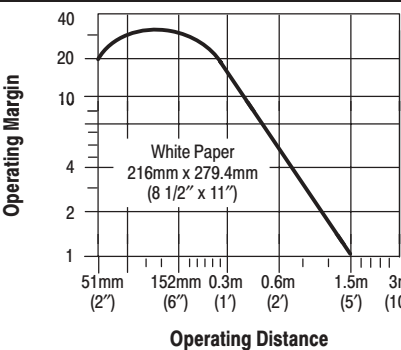
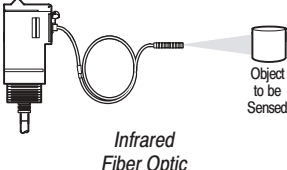
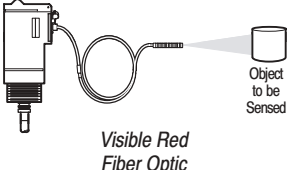
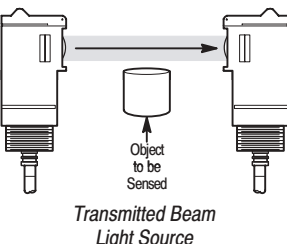
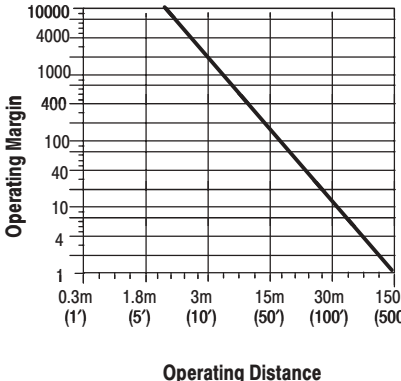
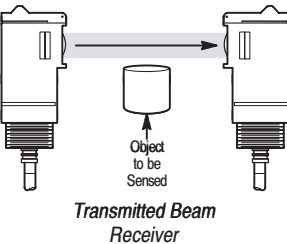
Sensing Mode	Min/Max Sensing Distance	Protocol	Connection Type	Catalog Number	Typical Response Curve
 <p><i>Standard Diffuse</i></p>	50.8mm (2in) 1.52m (5ft) to White Paper	Strobing and COS	2m CPE cable	<b>42GNP-9020</b>	
			5-pin DC micro QD	<b>42GNP-9020-QD</b>	
			5-pin mini QD	<b>42GNP-9020-QD1</b>	
 <p><i>Infrared Fiber Optic</i></p>	Depends on fiber optic cable selected	Strobing and COS	2m CPE cable	<b>42GNF-9020</b>	<p>Range varies with fiber optic selected. Refer to standard Series 9000 in C114 <i>Sensors</i> catalog for typical response curves.</p>
			5-pin DC micro QD	<b>42GNF-9020-QD</b>	
			5-pin mini QD	<b>42GNF-9020-QD1</b>	
 <p><i>Visible Red Fiber Optic</i></p>	Depends on fiber optic cable selected	Strobing and COS	2m CPE cable	<b>42GNF-9120</b>	
			5-pin DC micro QD	<b>42GNF-9120-QD</b>	
			5-pin mini QD	<b>42GNF-9120-QD1</b>	
 <p><i>Transmitted Beam Light Source</i></p>	152m (500ft)	—	2m 300V cable	<b>42GNL-9040</b>	
			5-pin DC micro QD	<b>42GNL-9040-QD</b>	
			5-pin DC mini QD	<b>42GNL-9040-QD1</b>	
 <p><i>Transmitted Beam Receiver</i></p>	152m (500ft)	Strobing	2m CPE cable	<b>42GNR-9000</b>	
			5-pin DC micro QD	<b>42GNR-9000-QD</b>	
			5-pin mini QD	<b>42GNR-9000-QD1</b>	
		COS	2m CPE cable	<b>42GNR-9010</b>	
			5-pin DC micro QD	<b>42GNR-9010-QD</b>	
			5-pin mini QD	<b>42GNR-9010-QD1</b>	

**Accessories**

Description	Catalog Number	Description	Catalog Number
Reflector, 76mm (3in) Diameter with Center Mount Hole	<b>92-39</b>	Mounting Bracket Swivel/Tilt (nonClearSight models)	<b>60-2439</b>
Reflector, 32mm (1.25in) Diameter	<b>92-47</b>	Mounting Bracket Swivel/Tilt (ClearSight models)	<b>60-2681</b>

# 871TM DeviceNet Sensors

## Inductive Proximity Sensors



871TM DeviceNet Cable Style  
18, 30mm  
page NO TAG



871TM DeviceNet Mini  
Quick-Disconnect Style  
18, 30mm  
page NO TAG



871TM DeviceNet Micro  
Quick-Disconnect Style  
18, 30mm  
page NO TAG



### Features

- Connects directly to DeviceNet networks
- Autobaud
- Discrete and Analog output
- Diagnostic capabilities available
  - Object too close
  - Sensor operational
  - Object too far
- Timing functions: On, Off, and One-Shot Delay configuration
- Configurable normally open/normally closed
- Motion detection
- Teach/learn target capabilities
- UL listed, c-UL certified, and CE marked for all applicable directives

### Specifications

<b>Current Drain</b>	≤60mA
<b>Operating Voltage</b>	11-25V DC
<b>Repeatability</b>	≤1% at constant temperature
<b>Hysteresis</b>	10% typical
<b>Approvals</b>	UL listed, c-UL certified, and CE marked for all applicable directives
<b>Enclosure</b>	NEMA 1, 2, 3, 3R, 4, 4X, 6, 6P, 12, 13; IP67 (IEC 529), 1200psi (8270kPa) washdown Stainless steel face and barrel
<b>Connections</b>	Cable: 2m (6.5ft) length Quick-Disconnect: 5-pin mini style 5-pin micro style
<b>LEDs</b>	Bicolor Red/Green: DeviceNet Network/Status Amber: Output energized
<b>Operating Temperature</b>	-25°C to +70°C (-13°F to +158°F)
<b>Shock</b>	30g, 11ms
<b>Vibration</b>	55Hz, 1mm amplitude, 3 planes

### Correction Factors

Target Material	Correction Factor
Steel	1.0
Stainless Steel	0.9-1.0
Brass	0.3-0.5
Aluminum	0.1-0.4
Aluminum ≤0.020 Thick	0.9-1.1
Copper	0.4-0.6

### Indicators (refer to illustration)

Label	Color	State	Status
Output	Yellow	On	Target detected
Status	Red/Green	Off	Sensor not powered
		Green On Steady	Sensor active and allocated by a Master
		Green Flashing	Sensor active but not allocated by a Master
		Red Flashing	Minor correctable fault (baud rate)
		Red On Steady	Major fault (possible duplicate address)

### I/O Data

Strobe and Change-of-State Output:

Byte 1	Bit 0	Bit 1	Bit2	Bit 3	Bit 4	Bit 5	Bit 6	Bit 7
Sensor Output	Diagnostics	Coil Operational	Too Close	Too Far	Always In	Motion Detect	Counter Output	
Byte 2	Bit 0	Bit 1	Bit2	Bit 3	Bit 4	Bit 5	Bit 6	Bit 7
Analog Output (Strobe Only)								

### Product Selection

Barrel Dia.	Nominal Sensing Distance mm (inches)	Shielded	Output Configuration	Catalog Number		
				Cable Style	Mini QD Style	Micro QD Style
18mm	5 (0.20)	Y	Programmable N.O./N.C.	871TM-D5ED18-S2	871TM-D5ED18-N5	871TM-D5ED18-D5
	8 (0.31)	N		871TM-D8ED18-S2	871TM-D8ED18-N5	871TM-D8ED18-D5
30mm	10 (0.39)	Y		871TM-D10ED30-S2	871TM-D10ED30-N5	871TM-D10ED30-D5
	15 (0.59)	N		871TM-D15ED30-S2	871TM-D15ED30-N5	871TM-D15ED30-D5

### Accessories

Description	Page Number
Terminal Chambers	NO TAG
Mounting Brackets	R2-196 - R2-200
End Caps	R2-205, R2-206
Mounting Nuts	R2-207 - R2-208

### Dimensions—mm (inches)

#### Cable Style

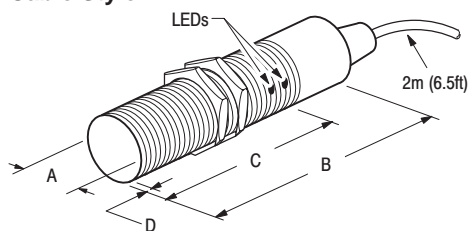

#### Cable Style

Thread Size	Shielded	mm (inches)			
		A	B	C	D
M18 x 1	Y	18.0 (0.71)	74.7 (2.94)	60.0 (2.36)	2.5 (0.10)
	N			48.2 (1.90)	14.4 (0.56)
M30 x 1.5	Y	30.0 (1.18)	77.2 (3.04)	61.3 (2.41)	2.5 (0.10)
	N			41.6 (1.64)	17.9 (0.70)

#### Mini QD Style

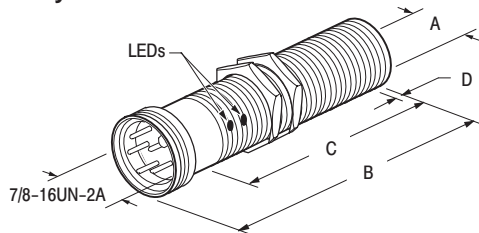

#### Micro QD Style

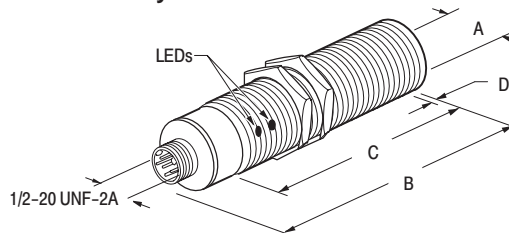

Mini QD Style						Micro QD Style					
Thread Size	Shielded	mm (inches)				Thread Size	Shielded	mm (inches)			
		A	B	C	D			A	B	C	D
M18 X 1	Y	18.0 (0.71)	76.6 (3.02)	54.9 (2.16)	2.5 (0.10)	M18 X 1	Y	18.0 (0.71)	84.3 (3.32)	60.0 (2.36)	2.5 (0.10)
	N			43.1 (1.70)	14.4 (0.56)		N			48.2 (1.90)	14.4 (0.56)
M30 X 1.5	Y	30.0 (1.18)	86.4 (3.40)	61.3 (2.41)	2.5 (0.10)	M30 X 1.5	Y	30.0 (1.18)	85.7 (3.37)	61.3 (2.41)	2.5 (0.10)
	N			41.6 (1.64)	17.9 (0.70)		N			46.1 (1.81)	17.9 (0.70)

**802DN Lever Type with DeviceNet Output • Spring Return****NonPlug-In Style Oiltight Switches**

*NonPlug-In Style  
802DN-AD5 without  
Lever*

**Description**

Bulletin 802DN DeviceNet limit switches have been designed with the same rugged features of our 802T NEMA limit switches with the features and benefits of DeviceNet built in. These limit switches utilize DeviceNet technology to address the primary customer needs. The three most common needs are increased information flow, an inexpensive way to connect limit switches to a DeviceNet network, and finally, reduction of down time by using the advanced diagnostic capabilities only available through DeviceNet. 802DN limit switches are configured using RSNetWorx for DeviceNet. On line configuration help is available using the parameter help feature.

**Features**

- Direct connection to DeviceNet network
- Autobaud
- Dual outputs with distinct programmable angles to operate
- Teach and learn angle
- Each output programmable to N.O. or N.C.
- Programmable travel to reset (hysteresis)
- Configurable counters with resets on each output

**Specifications**

<b>Enclosure Rating</b>	NEMA 1, 4, 6P, 13 and IP67 (IEC 529)
<b>Approvals</b>	UL listed, CSA certified, and CE marked for applicable directives
<b>Ambient Temperature</b>	NonPlug-In limit switches are designed to operate in an ambient temperature range of -18°C to +54°C (0°F to +130°F).

**Features (continued)**

- Multiple timing functions
  - Programmable in 1ms increments
    - On delay timer
    - Off delay timer
    - One shot timer
- User-selectable discrete or analog output
- Multiple maintenance warnings
  - Overtravel alarm
  - Motion detection
  - Slow lever return alarm
  - Jam detect
- User defined counter preset used for Tracking total operations and maintenance alarming
- Supports change of state (COS) or strobing protocol

**High Degree of Versatility**

Bulletin 802DN limit switches can be mounted in any position, with operating heads that can be rotated and fastened in any one of four positions 90° apart. Most operating levers are interchangeable and can be rotated and clamped in any position through 360°.

**NEMA Type 13 Construction**

802DN limit switches feature NEMA Type 13 construction with synthetic rubber seals to protect the operating parts against entry of oil, dust, abrasives, water and coolant, within the limits of NEMA-specified tests.

**Easy Mounting and Wiring**

Each switch base has four mounting holes: two “through” holes for front mounting and two tapped holes in the back for rear mounting. Three different wiring styles are available for ease of installation. Each of the models is available for order with one of the following: a five-pin micro quick-disconnect, a five-pin mini quick-disconnect, or a prewired two meter cable.

**Lever Type Switches**

These switches are operated by means of a lever which is clamped to a knurled shaft extending from the operating head.

Lever type switches can be equipped with a variety of operating levers: roller lever, adjustable roller lever, micrometer adjustment roller lever, rod lever, one-way rod or roller lever and fork lever. These can be used interchangeably on all lever type switches.

The micrometer adjustment roller lever, catalog number **802T-W6**, is designed especially for installations where the exact position of the roller is critical. This lever has a pivoted roller which can be turned laterally. After clamping the lever to the switch shaft, the position of the roller can be precisely adjusted through an arc of 7.5° on either side of the center or straight-line position.

**Wide Belt Roller**

The **802DN-WBR-XX** limit switches come packaged with a special lever arm. This limit switch has been specifically designed for precise position detection of conveyor belts. By using the advanced features of DeviceNet, this limit switch is ideal for this application.

**Operating Levers**

See pages 6–91 through 6–96.

# 802DN Lever Type with DeviceNet Output • Spring Return

## NonPlug-In Style Oiltight Limit Switches

### Range of Operation

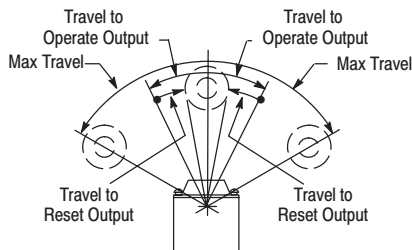

Switch  
Without Lever

### Product Selection

Lever Movement	Torque to Operate (Max)	Travel to Operate Output #1	Travel to Operate Output #2	Max Travel	Travel to Reset	Lever	Connection Type	Catalog Number
Clockwise or Counterclockwise	0.34N.m (3lb in)	Programmable	Programmable	54°	Programmable (5° min)	None	2m cable	802DN-AS2
							5-pin mini	802DN-AN5
							5-pin micro	802DN-AD5
						Wide belt roller	2m cable	802DN-WBRS2
							5-pin mini	802DN-WBRN5
5-pin micro	802DN-WBRD5							

### I/O Data

Byte 1								Byte 2							
Bit 0	Bit 1	Bit 2	Bit 3	Bit 4	Bit 5	Bit 6	Bit 7	Bit 0	Bit 1	Bit 2	Bit 3	Bit 4	Bit 5	Bit 6	Bit 7
Output 1	Output 2	Maintenance Diagnostic	Over Travel	Slow Return	Counter 1 Output	Counter 2 Output	Not Used	Analog Output (Strobe Only)							

Outputs 1 and 2 are programmable N.O./N.C.  
See electronic data sheet for programming instructions.

### Dimensions—mm (inches)

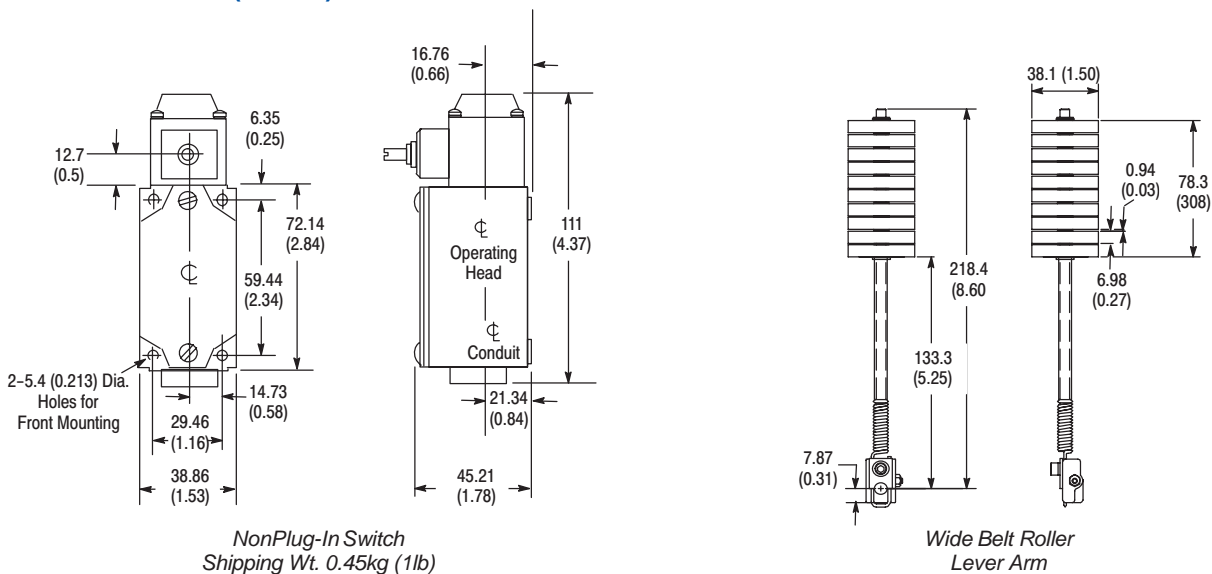

# Bulletin 842D DeviceNet Absolute Multi-Turn Magnetic Encoder



DeviceNet Encoder



## Description

The Bulletin 842D offers direct connection to DeviceNet for advanced functionality with reduced wiring cost. The following is a partial feature list:

## General Features

- Magnetic design withstands 100g shock and temperature extremes
- 26 bit multi-turn absolute encoder retains position data if power is lost
- Up to 8192 PPR & 8192 turns
- Connects via 5 pin micro QD
- Slotted rear cover allows address and baud rate selection
- Position Reset Button
- NEMA 4 / IP66 Housing

## Programmable Features

- Current position (0 to 67,108,864)
- Counts per revolution (1 to 8192)
- Revolutions (1 to 8192)
- Eight Programmable Cams with high/low limits & hysteresis
- Position change required for COS communication
- Counting direction (cw/ccw)

## Diagnostic Features

- Red & Green LEDs
- Cumulative operating time
- Min/Max acceleration & velocity
- Maximum velocity warning flag
- Current velocity (RPM, RPS or STEPS/SEC)

## Specifications

Electrical	
Code Format	Natural Binary
Code Direction	CW or CCW (programmable)
Electrical Interface	DeviceNet specification release 2.0
Operating Voltage	11–25V DC (24V DC recommended)
Power Requirements	1.8W
Max # of Steps/Revolution	8192
Max # of Revolutions	8192
Position Forming Time	0.3msec
Delay on Power Up	1050msec
Preset Position	Via covered rear button or DeviceNet
Mechanical	
Angular Acceleration	$5 \times 10^5$ radians/sec <sup>2</sup>
Moment of Inertia	35gcm <sup>2</sup> ( $5.0 \times 10^{-4}$ oz-in-sec <sup>2</sup> )
Operating Speed	6000 RPM at max shaft loading
Starting Torque	2.5Ncm (3.5oz-in)
Shaft Loading	Axial 11lb (50N) Radial 67lb (300N)
Environmental	
Housing	Aluminum
Temperature	-20°C to 85°C (-4°F to +185°F)—Operating -40°C to 125°C (-40°F to +257°F)—Storage
Humidity	98% noncondensing
Protection	NEMA Type 4, 13, IP66 (IEC 529)
Shock	100g/6msec
Vibration	20g/10–2000Hz
Approximate Weight	0.91kg (2lbs)

## Accessories

Description	Page Number
Flexible Couplings	R6-43
Servo Clamps	R6-44
Mating Connectors	R8-5 and R8-10
Mounting Plates	R6-48

## Indicators

LED	Status
Off	Not connected not on-line
Green Blinking	Active but not allocated by master
Green Steady	Active and allocated by master
Red Blinking	Minor fault and/or connection interrupt
Red Steady	Critical communication fault





DeviceLink



NRTL/C

### Specifications

Electrical Requirements	
Supply Voltage	11V min to 25V max
Sensor Type Supported	24V DC with sourcing (PNP) output, 2-wire, 3-wire, or 4-wire
Sensor Input “0” Level	0V–0.7V, sourcing 0mA–1.65mA (with respect to ground)
Sensor Input “1” Level	3V to max supply voltage (with respect to ground)
Environmental Requirements	
Operational Temperature	–25°C to +70°C (–13°F to +158°F)
Storage Temperature	–40°C to +85°C (–40° to +185°F)
Vibration	5g, 150Hz, 3 mutually perpendicular planes
Sealing	1200PSI (8270 kPa) NEMA 6P, 4X, 12, and 13
Network	
Maximum Power Consumption	40mA + End Device
Messaging Type	Slave Mode
Exchange Method	Strobe
Strobe Format	Output –byte 1 bit 0

### Description

Serving as a gateway between a 24V DC sensing device and DeviceNet™, Rockwell Automation/Allen-Bradley introduces DeviceLink™. Each DeviceLink is a single node on the DeviceNet network. It communicates on the network per the DeviceNet protocol at 125kb, 250kb, and 500kb. DeviceLink is compatible with any 2-wire or 3-wire 24V sensor with open collector sourcing output, any device with relay contacts, and any mechanical sensing device.

### Features

- Offered in a variety of cable lengths
- Contains debounce filtering configurable by user
- Offered in mini quick-disconnect, micro quick-disconnect, and Conductor
- Stainless steel connectors
- CSA, NRTL/C approved
- Network Status Indicator

### Factory Defaults

DeviceNet Address . . . . . 63  
 DeviceNet Baud Rate . . . 125kb  
 On/Off Delay . . . . . 0ms

**Note:** All parameters are configurable via the network.

### Status Indicators

LED	Status
None	Indicates sensor not powered
Green On	Sensor active and allocated by a master
Flashing Green	Sensor active but not allocated by a master
Flashing Red	Incorrect baud rate or communication lost
Red On	Misappropriating (possible duplicate address or communication error)

**Product Selection**

DeviceNet Connection	Field Device Connection	Catalog Number—Length m (ft)		
		1 (3.3)	2 (6.5)	3 (9.8)
Straight Mini	Straight Mini	1485D-A1M5-N4	1485D-A2M5-N4	1485D-A3M5-N4
	Straight Micro	1485D-A1M5-R4	1485D-A2M5-R4	1485D-A3M5-R4
	Cable	1485D-A1M5-C	1485D-A2M5-C	1485D-A3M5-C
Right Angle Micro	Straight Mini	1485D-A1F5-N4	1485D-A2F5-N4	—
	Straight Micro	1485D-A1F5-R4	1485D-A2F5-R4	
	Cable	1485D-A1F5-C	1485D-A2F5-C	
Cable	Straight Mini	—	—	1485D-A3C3-N4
	Straight Micro			1485D-A3C3-R4
	Cable			1485D-A3C3-C

❶ For stainless steel connectors add an "S" to the catalog number: example 1485DS-A1M5-N4

**Dimensions—mm (inches)**

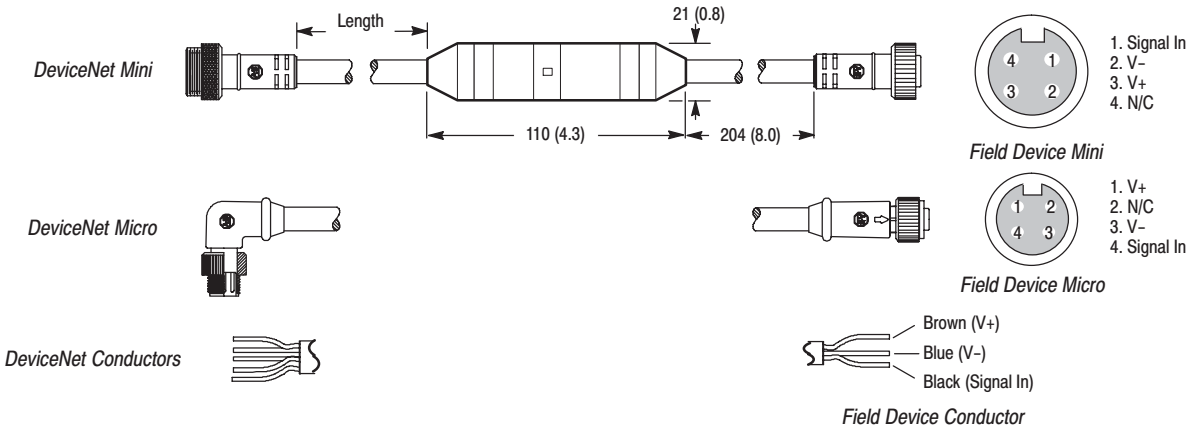

Notes

---