



General Information	Quick Selection Guide	page R4–2
	Technical Definitions and Terminology	page R4–3
	Introduction	page R4–5
Products	875C and 875CP Nickel-Plated and Plastic Barrel	page R4–9
	Accessories	Mounting Brackets, Sight Glass Style
Sensor Wells		page R4–22
Indexes	Catalog Number Index	page R10–1
	Comprehensive Product Index	page R11–1

Capacitive Proximity Sensors

Quick Selection Guide

Specifications	 <p>875C and 875CP General Purpose Tubular</p>		 <p>875C and 875CP Plastic Barrel Tubular</p>	
Description	<ul style="list-style-type: none"> Nickel-plated brass barrel 		<ul style="list-style-type: none"> Plastic Barrel 	
Features	<ul style="list-style-type: none"> Capacitive technology senses metals and nonmetals, liquid and solids Adjustable sensing distance 3-wire DC and 2-wire AC models DC models have short circuit, overload, transient noise, and reverse polarity protection Cable or quick-disconnect styles 		<ul style="list-style-type: none"> Capacitive technology senses metals and nonmetals, liquid and solids Adjustable sensing distance 3-wire DC and 2-wire AC models DC models have short circuit, overload, transient noise, and reverse polarity protection Cable or quick-disconnect styles 	
Operating Voltage	<ul style="list-style-type: none"> 10-48V DC 	<ul style="list-style-type: none"> 24-240V AC 	<ul style="list-style-type: none"> 10-48V DC 	<ul style="list-style-type: none"> 24-240VAC
Diameter	<ul style="list-style-type: none"> 12, 18, 30mm 	<ul style="list-style-type: none"> 18, 30mm 	<ul style="list-style-type: none"> 18, 30, 34mm 	<ul style="list-style-type: none"> 18, 30, 34mm
Available Models	<ul style="list-style-type: none"> DC 3-Wire Nickel-Plated Brass Barrel 	<ul style="list-style-type: none"> AC 2-Wire Nickel-Plated Brass Barrel 	<ul style="list-style-type: none"> DC 3-Wire Plastic Barrel 	<ul style="list-style-type: none"> AC 2-Wire Plastic Barrel
Connection	<ul style="list-style-type: none"> PVC Cable Pico QD (18mm) Micro QD (30mm) 	<ul style="list-style-type: none"> PVC Cable Micro QD (30mm) 	<ul style="list-style-type: none"> PVC Cable Pico QD (18mm) Micro QD (30 & 34mm) 	<ul style="list-style-type: none"> PVC Cable Micro QD (30 & 34mm)
Enclosure	<ul style="list-style-type: none"> Nickel-plated brass barrel NEMA 1, 3, 4, 6, 13 and IP67 		<ul style="list-style-type: none"> Plastic barrel NEMA 12, IP67 (IEC 529) 	
Additional Info	<ul style="list-style-type: none"> See page R4-10 	<ul style="list-style-type: none"> See page R4-16 	<ul style="list-style-type: none"> See page R4-13 	<ul style="list-style-type: none"> See page R4-18

Axial Approach: The approach of the target with its center maintained on the reference axis.

Complementary Outputs: (N.O. & N.C.) A proximity sensor that features both normally open and normally closed outputs, which can be used simultaneously.

Correction Factors: Suggested multiplication factors taking into account variations in the target material composition. When figuring actual sensing distance this factor should be multiplied with the nominal sensing distance.

Current Consumption: The current consumed by the proximity switch when the output device is in the off condition.

Differential Travel: See Hysteresis.

Dual Output: Sensor which has two outputs which may be complementary or may be of a single type (i.e. two normally open or two normally closed).

Effective Operating Distance: (Sr) The operating distance of an individual proximity switch measured at stated temperature, voltage, and mounting condition.

False Pulse: An undesired change in the state of the output of the proximity switch that lasts for more than two milliseconds.

Flush Mounting: A shielded proximity sensor which can be flush mounted in metal up to the plane of the active sensing face.

Free Zone: The area around the proximity switch which must be kept free from any damping material.

Hysteresis: The difference, in percentage (%), of the nominal sensing distance between the operate (switch on) and release point (switch off) when the target is moving away from the sensors active face. Without sufficient hysteresis a proximity sensor will “chatter” (continuously switch on and off) when there is significant vibration applied to the target or sensor.

Isolation Voltage: Maximum rated voltage between isolated outputs or input and output.

Lateral Approach: The approach of the target perpendicular to the reference axis.

Leakage Current: Current which flows through the output when the output is in an “off” condition or de-energized. This current is necessary to supply power to the electronics of the sensor.

LED: Light Emitting Diode used to indicate sensor status.

Maximum Load Current: The maximum current level at which the proximity sensor can be continuously operated.

Maximum Inrush Current: The maximum current level at which the proximity sensor can be operated for a short period of time.

Minimum Load Current: The minimum amount of current required by the sensor to maintain reliable operation.

Sensing Distance: The distance at which an approaching target activates (changes state of) the proximity output.

Normally Closed: Output opens when an object is detected in the active switching area.

Normally Open: Output closes when an object is detected in the active switching area.

NPN: The sensor switches the load to the negative terminal. The load should be connected between the sensor output and positive terminal.

Operating Distance, Rated: The operating distance specified by the manufacturer and used as a reference value. Also known as nominal sensing distance.

PNP: The sensor switches the load to the positive terminal. The load should be connected between the sensor output and negative terminal.

Programmable Output: (N.O. or N.C.) Output which can be changed from N.O. to N.C. or N.C. to N.O. by way of a switch or jumper wire. Also known as selectable output.

Repeatability: The variation of the effective operating distance measured at room temperature and constant supply voltage. It is expressed as a percentage of the sensing distance.

Residual Voltage: The voltage across the sensor output while energized and carrying maximum load current.

Response Time: See Switching Frequency.

Reverse Polarity Protection: Proximity sensors which are protected against a reversal in voltage polarity.

Ripple: The variance between peak-to-peak values in DC voltage. It is expressed in percentage of rated voltage.

Sensing Range: The rated operating distance.

Shielded: Sensor which can be flush mounted in metal up to the plane of the active sensing face.

Short Circuit Protection: (SCP) Sensor protected from damage when a shorted condition exists for an indefinite or defined period of time.

Sinking: See NPN.

Sourcing: See PNP.

Switching Frequency: The maximum number of times per second the sensor can change state (ON and OFF) usually expressed in Hertz (Hz). As measured in DIN EN 50010.

Target: Object which activates the sensor.

Three-Wire Proximity Switch: An AC or DC proximity sensor with three leads, two of which supply power and a third that switches the load.

Two-Wire Proximity Switch: A proximity sensor which switches a load connected in series to the power supply. Power for the proximity switch is obtained through the load at all times.

Voltage Drop: The maximum voltage drop across a conducting sensor.

Notes

Principles of Operation for Capacitive Proximity Sensors

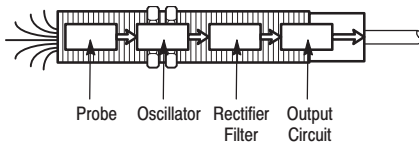

Capacitive proximity sensors are designed to operate by generating an electrostatic field and detecting changes in this field caused when a target approaches the sensing face. The sensor's internal workings consist of a capacitive probe, an oscillator, a signal rectifier, a filter circuit and an output circuit.

In the absence of a target, the oscillator is inactive. As a target approaches, it raises the capacitance of the probe system. When the capacitance reaches a specified threshold, the oscillator is activated which triggers the output circuit to change between "on" and "off."

The capacitance of the probe system is determined by the target's size, dielectric constant and distance from the probe. The larger the size and dielectric constant of a target, the more it increases capacitance. The shorter the distance between target and probe, the more the target increases capacitance.

Standard Target and Grounding for Capacitive Proximity Sensors

The standard target for capacitive sensors is the same as for inductive proximity sensors. The target is grounded per IEC test standards. However, a target in a typical application does not need to be grounded to achieve reliable sensing.

Shielded vs. Unshielded Capacitive Sensors

Shielded capacitive proximity sensors are best suited for sensing low dielectric constant (difficult to sense) materials due to their highly concentrated electrostatic fields. This allows them to detect targets which unshielded sensors cannot. However, this also makes them more susceptible to false triggers due to the accumulation of dirt or moisture on the sensor face.

The electrostatic field of an unshielded sensor is less concentrated than that of a shielded model. This makes them well suited for detecting high dielectric constant (easy to sense) materials or for differentiating between materials with high and low constants. For the right target materials, unshielded capacitive proximity sensors have longer sensing distances than shielded versions.

Unshielded capacitive sensors are also more suitable than shielded types for use with plastic sensor wells, an accessory designed for liquid level applications. The well is mounted through a hole in a tank and the sensor is slipped into the well's receptacle. The sensor detects the liquid in the tank through the wall of the sensor well. This allows the well to serve both as a plug for the hole and a mount for the sensor.

Target Correction Factors for Capacitive Proximity Sensors

For a given target size, correction factors for capacitive sensors are determined by a property of the target material called the dielectric constant. Materials with higher dielectric constant values are easier to sense than those with lower values. A partial listing of dielectric constants for some typical industrial materials follows. For more information, refer to the *CRC Handbook of Chemistry and Physics (CRC Press)*, the *CRC Handbook of Tables for Applied Engineering Science (CRC Press)*, or other applicable sources.

Dielectric Constants of Common Industrial Materials

Acetone	19.5
Acrylic Resin	2.7-4.5
Air	1.000264
Alcohol	25.8
Ammonia	15-25
Aniline	6.9
Aqueous Solutions	50-80
Bakelite	3.6
Benzene	2.3
Carbon Dioxide	1.000985
Carbon Tetrachloride	2.2
Celluloid	3.0
Cement Powder	4.0
Cereal	3-5
Chlorine Liquid	2.0
Ebonite	2.7-2.9
Epoxy Resin	2.5-6
Ethanol	24
Ethylene Glycol	38.7
Fired Ash	1.5-1.7
Flour	1.5-1.7
Freon R22 & 502 (liquid)	6.11
Gasoline	2.2
Glass	3.7-10
Glycerine	47
Marble	8.0-8.5
Melamine Resin	4.7-10.2
Mica	5.7-6.7
Nitrobenzene	36
Nylon	4-5
Oil Saturated Paper	4.0
Paraffin	1.9-2.5
Paper	1.6-2.6
Perspex	3.2-3.5
Petroleum	2.0-2.2
Phenol Resin	4-12
Polyacetal	3.6-3.7
Polyamide	5.0
Polyester Resin	2.8-8.1
Polyethylene	2.3
Polypropylene	2.0-2.3
Polystyrene	3.0
Polyvinyl Chloride Resin	2.8-3.1
Porcelain	4.4-7
Powdered Milk	3.5-4
Press Board	2-5
Quartz Glass	3.7
Rubber	2.5-35
Salt	6.0
Sand	3-5
Shellac	2.5-4.7
Shell Lime	1.2
Silicon Varnish	2.8-3.3
Soybean Oil	2.9-3.5
Styrene Resin	2.3-3.4
Sugar	3.0
Sulphur	3.4
Teflon	2.0
Toluene	2.3
Transformer Oil	2.2
Turpentine Oil	2.2
Urea Resin	5-8
Vaseline	2.2-2.9
Water	80
Wood, Dry	2-7
Wood, Wet	10-30

Introduction

Shielded vs. Unshielded Construction

Each capacitive sensor can be classified as having either a shielded or unshielded construction.

Shielded Probe

Shielded sensors are constructed with a metal band surrounding the probe. This helps to direct the electrostatic field to the front of the sensor and results in a more concentrated field.

Shielded Probe

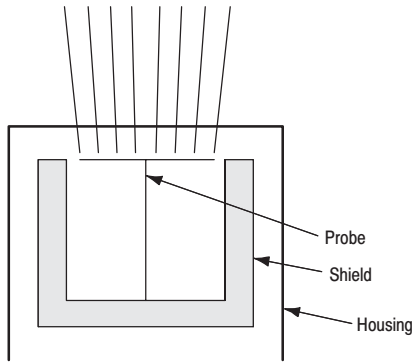

Shielded construction allows the sensor to be mounted flush in surrounding material without causing false trigger.

Shielded Sensors Flush Mounted

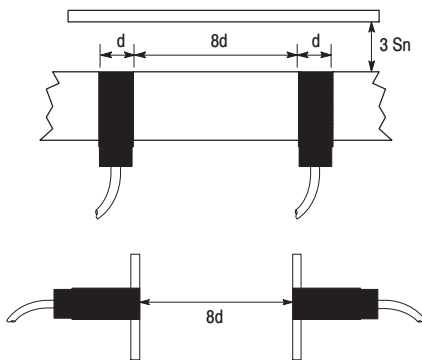

Shielded capacitive proximity sensors are best suited for sensing materials with low dielectric constants (difficult to sense) as a result of their highly concentrated electrostatic fields. This allows them to detect targets that unshielded sensors cannot.

Unshielded Probe

Unshielded sensors do not have a metal band surrounding the probe and hence have a less concentrated electrostatic field. Many unshielded models are equipped with compensation probes, which provide increased stability for the sensor. Compensation probes are discussed later in this section.

Unshielded Probe

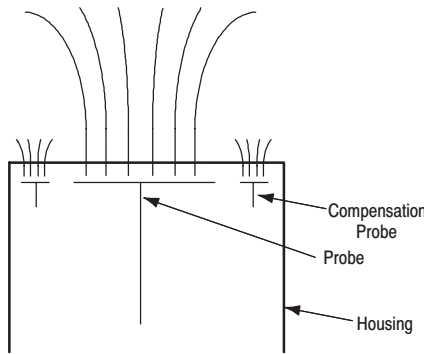

Unshielded capacitive sensors are also more suitable than shielded types for use with plastic sensor wells, an accessory designed for liquid level

applications. The well is mounted through a hole in a tank and the sensor is slipped into the well's receptacle. The sensor detects the liquid in the tank through the wall of the sensor well.

Unshielded Construction Mounted Above Metal and Mounted in Plastic Sensor Well

d for capacitive sensors if mounted in plastic. $3d$ (12, 18mm models) or $1.5d$ (30, 34mm models) if mounted in metal.

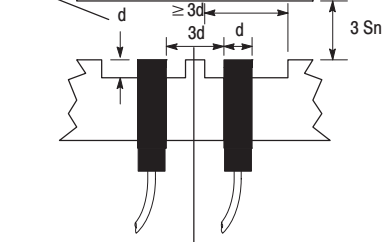

For capacitive sensors, $3d$ at medium sensitivity to $8d$ for maximum sensitivity.

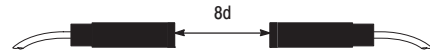

d = diameter or width of active sensing face
 S_n = nominal sensing distance

The electrostatic field of an unshielded sensor is less concentrated than that of a shielded model. This makes them well suited for detecting high dielectric constant (easy to sense) materials or for differentiating between materials with high and low constants. For certain target materials, unshielded capacitive proximity sensors have longer sensing distances than shielded versions.

Wood Industry

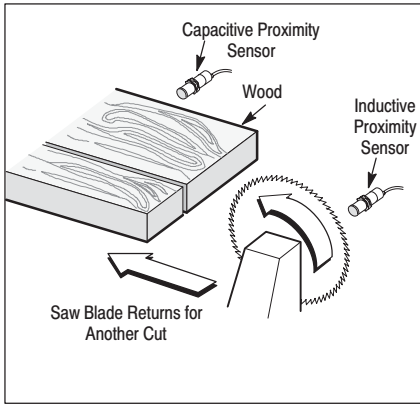

Level Detection

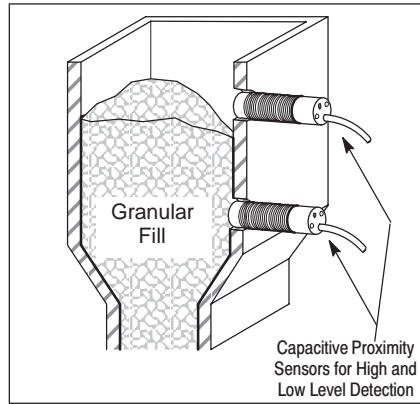

Liquid Level Detection

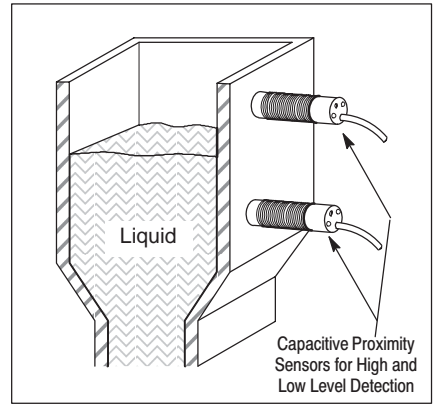

Food Processing

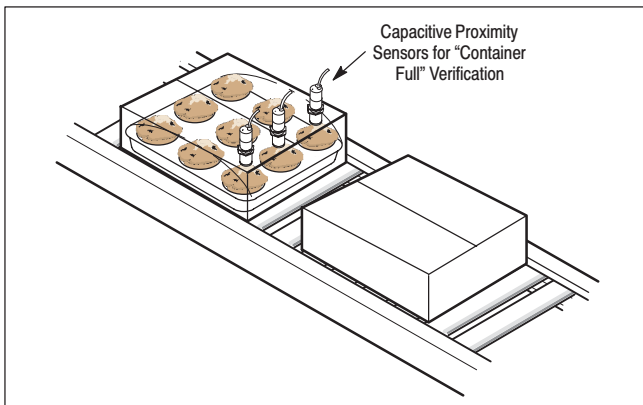

Sight-Tube Level Detection

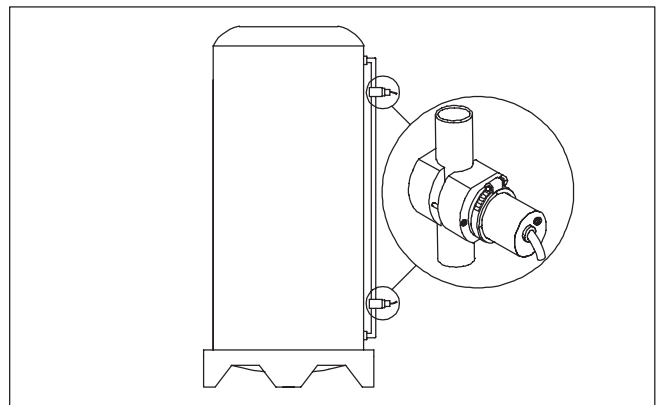

Notes



Description

Bulletin 875C and 875CP capacitive proximity sensors are self-contained solid-state devices designed for noncontact sensing of a wide range of materials.

Unlike inductive proximity sensors, the 875C and 875CP can detect nonmetal solids and liquids in addition to standard metal targets. They can even sense the presence of some targets through certain other materials, making them an ideal choice in some applications where inductive proximity and photoelectric sensors cannot be used.

Each unit has an adjustable sensing distance and is equipped with two LEDs to indicate power and output. They are housed in either a nickel-plated brass barrel (shielded models) or a plastic barrel (unshielded models) which meets NEMA 12 and IP67 (IEC 529) enclosure standards. Connection options include PVC cable as well as micro and pico quick-disconnect.

Features

- Metal, nonmetal solid and liquid sensing capability
- Adjustable sensing distance
- Cable or quick-disconnect styles
- Short circuit^❶, overload^❶, reverse polarity^❶, and transient noise protection
- Plastic models have glass filled nylon housings
- Meets NEMA 12 and IP67 (IEC 529) enclosure standards
- CE marked for all applicable directives

Styles

- DC 3-Wire Nickel-Plated Brass Barrel page R4-10
- DC 3-Wire Plastic Barrel page R4-13
- AC 2-Wire Nickel-Plated Brass Barrel page R4-16
- AC 2-Wire Plastic Barrel page R4-18

Accessories

- Quick-Disconnect Cables page R8-1
- Mounting Brackets
- Sight Glass Style page R4-21
- Sensor Wells page R4-22

^❶ DC models only.

875C 3-Wire DC

Plastic Face/Threaded Nickel-Plated Brass Barrel



875C DC Cable Style
12, 18, 30mm
page R4-11



875C DC Micro
Quick-Disconnect Style
18 and 30mm
page R4-12



875C DC Pico
Quick-Disconnect Style
18mm
page R4-12



Specifications

	12mm	18mm	30mm
Load Current	300mA	300mA	300mA
Leakage Current	0.3mA	0.1mA	0.1mA
Operating Voltage	10–48V DC	10–48V DC	10–48V DC
Voltage Drop	≤ 2V	≤ 2V	≤ 2V
Current Consumption	≤ 10mA		
Repeatability	≤ 10%		
Hysteresis	≤ 20%		
Transient Noise Protection	Incorporated		
Reverse Polarity Protection	Incorporated		
Short Circuit Protection	Incorporated		
Overload Protection	Incorporated		
Approval	CE marked for all applicable directives		
Enclosure	NEMA 1, 3, 4, 6, 13 and IP67; Nickel-plated brass barrel		
Connections	Cable: 2-meter length 3-conductor PVC Quick-Disconnect: 4-pin micro 3-pin pico		
LEDs	Green: Power Yellow: Output		
Operating Temperature	-25°C to +75°C (-13°F to +167°F)		

Correction Factors

Target Material	Correction Factor
Acetone	0.75
Acrylic Resin	0.10 - 0.25
Air	0.0
Alcohol	0.85
Ammonia	0.70 - 0.85
Aniline	0.40
Aqueous Solutions	0.98 - 1.0
Bakelite	0.20
Benzene	0.10
Carbon Dioxide	0.0
Carbon Tetrachloride	0.10
Celluloid	0.15
Cement Powder	0.25
Cereal	0.15 - 0.30
Chlorine Liquid	0.10
Ebonite	0.15
Epoxy Resin	0.15 - 0.35
Ethanol	0.85
Ethylene Glycol	0.93
Fired Ash	0.05
Flour	0.05
Freon R22 & 502 (liquid)	0.35
Gasoline	0.10
Glass	0.20 - 0.55
Glycerine	0.98
Marble	0.50
Melamine Resin	0.25 - 0.55
Mica	0.35
Nitrobenzine	0.93
Nylon	0.20 - 0.30
Oil Saturated Paper	0.25
Paraffin	0.10
Paper	0.10

Correction Factors

Target Material	Correction Factor
Perspex	0.15
Petroleum	0.05
Phenol Resin	0.20 - 0.60
Polyacetal	0.20
Polyamide	0.30
Polyester Resin	0.15 - 0.50
Polyethylene	0.10
Polypropylene	0.10
Polystyrene	0.15
Polyvinyl Chloride Resin	0.15
Porcelain	0.25 - 0.40
Powdered Milk	0.20
Press Board	0.10 - 0.30
Quartz Glass	0.20
Rubber	0.15 - 0.90
Salt	0.35
Sand	0.15 - 0.30
Shellac	0.15 - 0.25
Shell Lime	<0.05
Silicon Varnish	0.15
Soybean Oil	0.15
Styrene Resin	0.15
Sugar	0.15
Sulphur	0.15
PTFE	0.10
Toluene	0.10
Transformer Oil	0.10
Turpentine Oil	0.10
Urea Resin	0.30 - 0.45
Vaseline	0.10
Water	1.0
Wood, Dry	0.10 - 0.40
Wood, Wet	0.60 - 0.85

Features

- Metal, nonmetal solid and liquid sensing capability
- Adjustable sensing distance for 18mm and 30mm models
- 3-wire operation
- 3-conductor, 3-pin or 4-pin connection
- Normally open or normally closed output
- Short circuit, overload, reverse polarity, and transient noise protection
- CE marked for all applicable directives

Product Selection

Barrel Dia. & Type	Nominal Sensing Distance mm (in)	Shielded	Output Configuration		Switching Frequency (Hz)	Catalog Number			
						Cable Style	Micro QD Style	Pico QD Style	
12mm Threaded	2.5 (0.09)	Y	N.O.	PNP	100	875C-M2NP12-A2	—	—	
18mm Threaded	1 (0.04) to 5 (0.20)			NPN		875C-M5NP18-A2	—	875C-M5NP18-P3	
			N.C.	PNP		875C-M5NN18-A2	—	875C-M5NN18-P3	
				NPN		875C-M5CP18-A2	—	875C-M5CP18-P3	
			30mm Threaded	2 (0.08) to 10 (0.39)		N.O.	PNP	875C-M5CN18-A2	—
NPN	875C-M10NP30-A2						875C-M10NP30-D4	—	
N.C.	PNP				875C-M10NN30-A2	875C-M10NN30-D4	—		
	NPN				875C-M10CP30-A2	875C-M10CP30-D4	—		
						875C-M10CN30-A2	875C-M10CN30-D4	—	
Recommended Standard QD Cordset (-2 = 2m (6.5ft))						889D-F4AC-2	889P-F3AB-2		

QD Cordsets and Accessories

Description	Page Number
Mounting Brackets	R2-196 - R2-200
Mounting Nuts	R2-207 - R2-208
Terminal Chambers	R8-10
Other Cordsets Available	NO TAG, NO TAG

Dimensions—mm (inches)

Cable Style

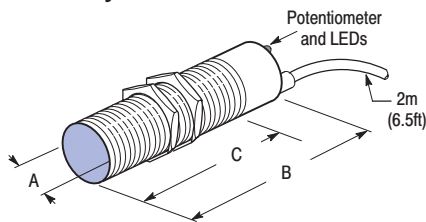

Wiring Diagram

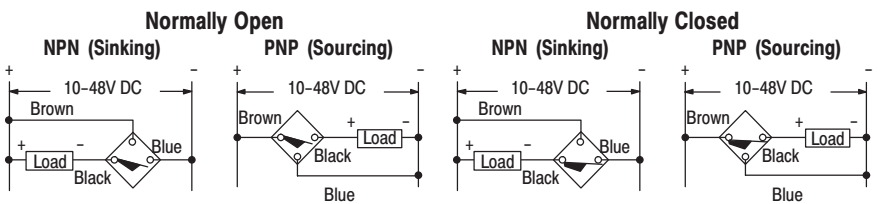

Thread Size	mm (inches)		
	A	B	C
M12 x 1	12.0 (0.47)	50.0 (1.96)	42.0 (1.65)
M18 x 1	18.0 (0.71)	52.0 (2.04)	47.4 (1.87)
M30 x 1.5	30.0 (1.18)	53.0 (2.08)	53.0 (2.08)

Capacitive Proximity Sensors

875C 3-Wire DC

Plastic Face/Threaded Nickel-Plated Brass Barrel

Dimensions—mm (inches)

Micro QD Style

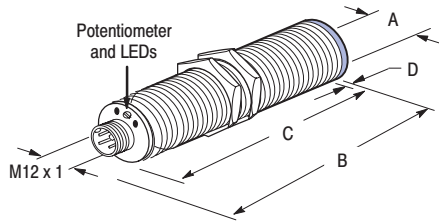

Wiring Diagram

Normally Open or Normally Closed

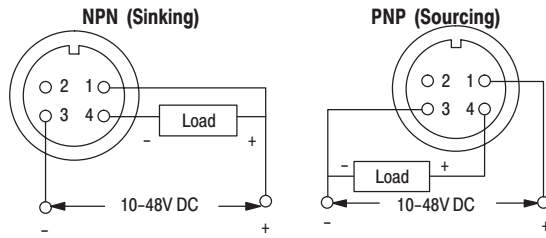

Thread Size	mm (inches)			
	A	B	C	D
M30 x 1.5	30.0 (1.18)	66.0 (2.60)	53.0 (2.08)	1.0 (0.04)

Pico QD Style

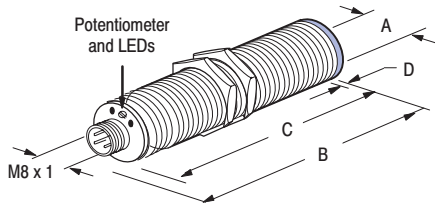

Normally Open or Normally Closed

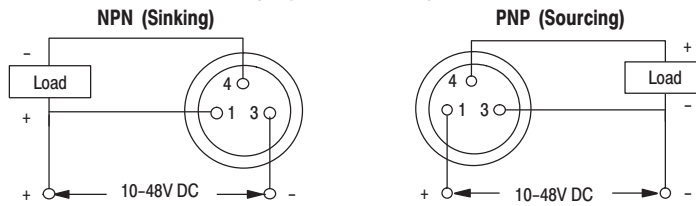

Thread Size	mm (inches)			
	A	B	C	D
M18 x 1	18.0 (0.71)	61.5 (2.42)	52.0 (2.04)	1.0 (0.04)



875CP DC Micro
Quick-Disconnect Style
Smooth Barrel 34mm
page R4-14



875CP DC Pico
Quick-Disconnect Style
Threaded Barrel 18mm
page R4-14

Specifications

Load Current	≤ 300mA
Leakage Current	0.01mA
Operating Voltage	10–48V DC
Voltage Drop	<2V
Current Consumption	≤ 10mA
Repeatability	≤ 10%
Hysteresis	≤ 20%
Transient Noise Protection	Incorporated
Reverse Polarity Protection	Incorporated
Short Circuit Protection	Incorporated
Overload Protection	Incorporated
Approval	CE marked for all applicable directives
Enclosure	NEMA 12, IP67 (IEC 529) Plastic barrel
Connections	Cable: 2-meter length 3-conductor PVC Quick-Disconnect: 4-pin micro 3-pin pico
LEDs	Green: Power Yellow: Output
Operating Temperature	–25°C to +70°C (–13°F to +158°F)



Features

- Metal, nonmetal solid and liquid sensing capability
- Adjustable sensing distance
- 3-wire operation
- 3-conductor, 3-pin or 4-pin connection
- 10–48V DC
- Normally open or normally closed output
- Short circuit, overload, reverse polarity and transient noise protection
- CE marked for all applicable directives

Correction Factors

Target Material	Correction Factor
Acetone	0.75
Acrylic Resin	0.10 - 0.25
Air	0.0
Alcohol	0.85
Ammonia	0.70 - 0.85
Aniline	0.40
Aqueous Solutions	0.98 - 1.0
Bakelite	0.20
Benzene	0.10
Carbon Dioxide	0.0
Carbon Tetrachloride	0.10
Celluloid	0.15
Cement Powder	0.25
Cereal	0.15 - 0.30
Chlorine Liquid	0.10
Ebonite	0.15
Epoxy Resin	0.15 - 0.35
Ethanol	0.85
Ethylene Glycol	0.93
Fired Ash	0.05
Flour	0.05
Freon R22 & 502 (liquid)	0.35
Gasoline	0.10
Glass	0.20 - 0.55
Glycerine	0.98
Marble	0.50
Melamine Resin	0.25 - 0.55
Mica	0.35
Nitrobenzine	0.93
Nylon	0.20 - 0.30
Oil Saturated Paper	0.25
Paraffin	0.10
Paper	0.10

Correction Factors

Target Material	Correction Factor
Perspex	0.15
Petroleum	0.05
Phenol Resin	0.20 - 0.60
Polyacetal	0.20
Polyamide	0.30
Polyester Resin	0.15 - 0.50
Polyethylene	0.10
Polypropylene	0.10
Polystyrene	0.15
Polyvinyl Chloride Resin	0.15
Porcelain	0.25 - 0.40
Powdered Milk	0.20
Press Board	0.10 - 0.30
Quartz Glass	0.20
Rubber	0.15 - 0.90
Salt	0.35
Sand	0.15 - 0.30
Shellac	0.15 - 0.25
Shell Lime	<0.05
Silicon Varnish	0.15
Soybean Oil	0.15
Styrene Resin	0.15
Sugar	0.15
Sulphur	0.15
PTFE	0.10
Toluene	0.10
Transformer Oil	0.10
Turpentine Oil	0.10
Urea Resin	0.30 - 0.45
Vaseline	0.10
Water	1.0
Wood, Dry	0.10 - 0.40
Wood, Wet	0.60 - 0.85

875CP 3-Wire DC

Plastic Face/Threaded or Smooth Plastic Barrel

Product Selection

Barrel Dia. & Type	Nominal Sensing Distance—mm (in)	Shielded	Output Configuration		Switching Frequency (Hz)	Catalog Number		
						Cable Style	Micro QD Style	Pico QD Style
18mm Threaded	2 (0.08) to 8 (0.31)	N	N.O.	PNP	100	875CP-N8NP18-A2	—	875CP-N8NP18-P3
				NPN		875CP-N8NN18-A2	—	875CP-N8NN18-P3
			N.C.	PNP		875CP-N8CP18-A2	—	875CP-N8CP18-P3
				NPN		875CP-N8CN18-A2	—	875CP-N8CN18-P3
30mm Threaded	5 (0.20) to 20 (0.79)		N.O.	PNP		875CP-N20NP30-A2	875CP-N20NP30-D4	—
				NPN		875CP-N20NN30-A2	875CP-N20NN30-D4	—
			N.C.	PNP		875CP-N20CP30-A2	875CP-N20CP30-D4	—
				NPN		875CP-N20CN30-A2	875CP-N20CN30-D4	—
34mm Smooth	7 (0.28) to 30 (1.18)	N.O.	PNP	875CP-NM30NP34-A2	875CP-NM30NP34-D4	—		
			NPN	875CP-NM30NN34-A2	875CP-NM30NN34-D4	—		
		N.C.	PNP	875CP-NM30CP34-A2	875CP-NM30CP34-D4	—		
			NPN	875CP-NM30CN34-A2	875CP-NM30CN34-D4	—		
Recommended Standard QD Cordset (-2 = 2m (6.5ft))						889D-F4AC-2	889P-F3AB-2	

QD Cordsets and Accessories

Description	Page Number
Mounting Brackets	R2-196 - R2-200
Mounting Nuts	R2-207 - R2-208
Sensor Wells	R4-22
Terminal Chambers	R8-10
Other Cordsets Available	NO TAG, NO TAG

Cable Style

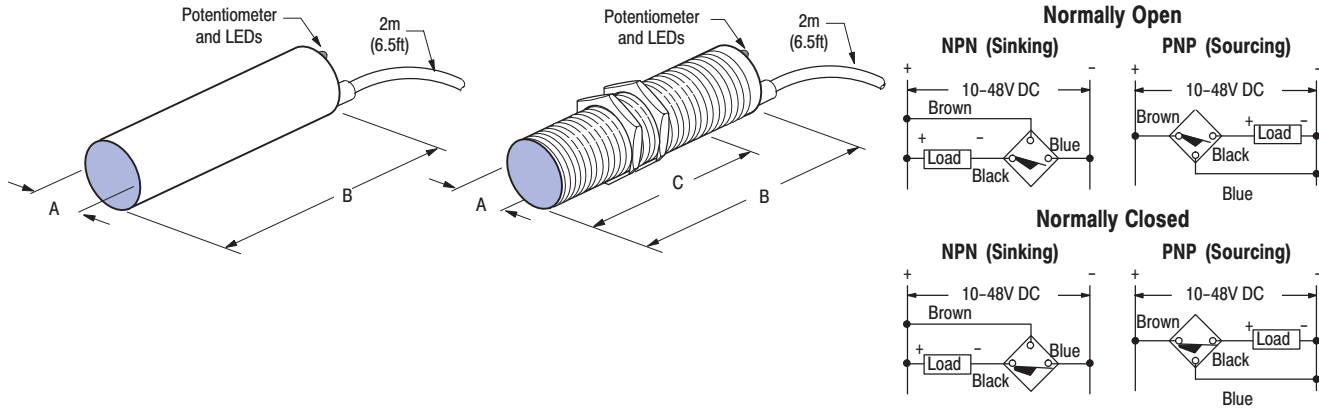

Diameter or Thread Size	mm (inches)		
	A	B	C
M18 x 1	18.0 (0.71)	52.0 (2.04)	52.0 (2.04)
M30 x 1.5	30.0 (1.18)		46.1 (1.81)
Ø34	34.0 (1.34)		N/A

Dimensions—mm (inches)

Micro QD Style

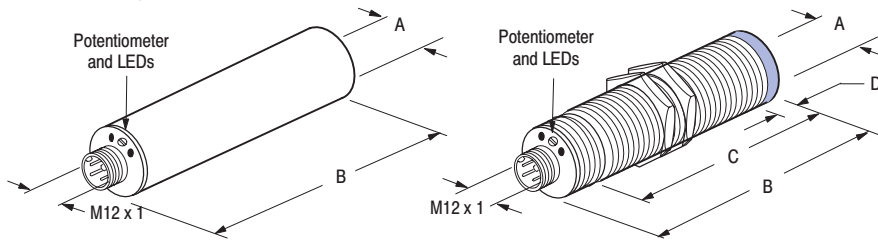

Wiring Diagram

**Normally Open or Normally Closed
NPN (Sinking)**

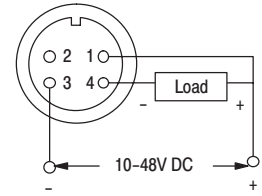

PNP (Sourcing)

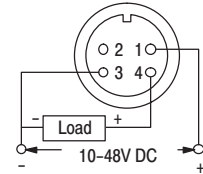

Diameter or Thread Size	mm (inches)			
	A	B	C	D
M30 x 1.5	30.0 (1.18)	65.0 (2.56)	52.0 (2.04)	1.0 (0.04)
∅34	34.0 (1.34)	65.0 (2.56)	N/A	N/A

Pico QD Style

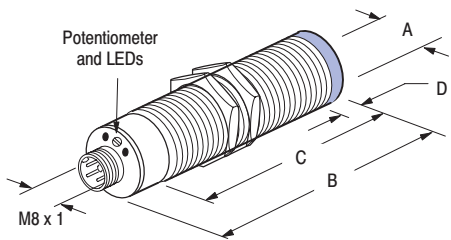

Normally Open or Normally Closed

NPN (Sinking)

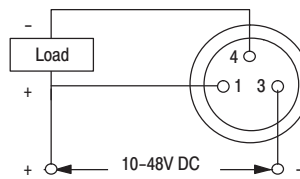

PNP (Sourcing)

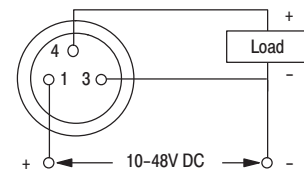

Diameter or Thread Size	mm (inches)			
	A	B	C	D
M18 x 1	18.0 (0.71)	61.5 (2.42)	52.0 (2.04)	1.0 (0.04)

875C 2-Wire AC

Plastic Face/Threaded Nickel-Plated Brass Barrel



875CP AC Cable Style
Threaded Barrel
18, 30mm
page R4-17



875CP AC Micro Quick-Disconnect Style
Threaded Barrel
30mm
page R4-17

Specifications

Load Current	≤ 300mA
Inrush Current	2A
Leakage Current	<1.5mA
Operating Voltage	24-240V AC
Voltage Drop	<7.5V AC
Repeatability	≤ 10%
Hysteresis	≤ 20%
Transient Noise Protection	Incorporated
Enclosure	NEMA 1, 3, 4, 6, 13 and IP67
Approval	CE marked for all applicable directives
Connections	Cable: 2-meter length 2-conductor PVC Quick-Disconnect: 3-pin micro
LEDs	Green: Power Yellow: Output
Operating Temperature	-25°C to +70°C (-13°F to +158°F)



Features

- Metal, nonmetal solid and liquid sensing capability
- Adjustable sensing distance
- 2-wire operation
- 2-conductor or 3-pin connection
- 24-240V AC
- Normally open or normally closed output
- Transient noise protection
- CE marked for all applicable directives

Correction Factors

Target Material	Correction Factor
Acetone	0.75
Acrylic Resin	0.10 - 0.25
Air	0.0
Alcohol	0.85
Ammonia	0.70 - 0.85
Aniline	0.40
Aqueous Solutions	0.98 - 1.0
Bakelite	0.20
Benzene	0.10
Carbon Dioxide	0.0
Carbon Tetrachloride	0.10
Celluloid	0.15
Cement Powder	0.25
Cereal	0.15 - 0.30
Chlorine Liquid	0.10
Ebonite	0.15
Epoxy Resin	0.15 - 0.35
Ethanol	0.85
Ethylene Glycol	0.93
Fired Ash	0.05
Flour	0.05
Freon R22 & 502 (liquid)	0.35
Gasoline	0.10
Glass	0.20 - 0.55
Glycerine	0.98
Marble	0.50
Melamine Resin	0.25 - 0.55
Mica	0.35
Nitrobenzine	0.93
Nylon	0.20 - 0.30
Oil Saturated Paper	0.25
Paraffin	0.10
Paper	0.10

Correction Factors

Target Material	Correction Factor
Perspex	0.15
Petroleum	0.05
Phenol Resin	0.20 - 0.60
Polyacetal	0.20
Polyamide	0.30
Polyester Resin	0.15 - 0.50
Polyethylene	0.10
Polypropylene	0.10
Polystyrene	0.15
Polyvinyl Chloride Resin	0.15
Porcelain	0.25 - 0.40
Powdered Milk	0.20
Press Board	0.10 - 0.30
Quartz Glass	0.20
Rubber	0.15 - 0.90
Salt	0.35
Sand	0.15 - 0.30
Shellac	0.15 - 0.25
Shell Lime	<0.05
Silicon Varnish	0.15
Soybean Oil	0.15
Styrene Resin	0.15
Sugar	0.15
Sulphur	0.15
PTFE	0.10
Toluene	0.10
Transformer Oil	0.10
Turpentine Oil	0.10
Urea Resin	0.30 - 0.45
Vaseline	0.10
Water	1.0
Wood, Dry	0.10 - 0.40
Wood, Wet	0.60 - 0.85

Product Selection

Barrel Diameter and Type	Nominal Sensing Distance mm (in)	Shielded	Output Configuration	Switching Frequency (Hz)	Catalog Number	
					Cable Style	Micro QD Style
18mm Threaded	1 (0.04) to 5 (0.20)	Y	N.O.	25	875C-F5N18-A2	—
			N.C.		875C-F5C18-A2	—
30mm Threaded	2 (0.08) to 10 (0.39)		N.O.		875C-F10N30-A2	875C-F10N30-R3
			N.C.		875C-F10C30-A2	875C-F10C30-R3
Recommended Standard QD Cordset (-2 = 2m (6.5ft))					889R-F3ACA-2	

QD Cordsets and Accessories

Description	Page Number
Mounting Brackets	R2-196 - R2-200
Mounting Nuts	R2-207 - R2-208
Sensor Wells	R4-22
Terminal Chambers	NO TAG
Other Cordsets Available	R8-6

Dimensions—mm (inches)

Cable Style

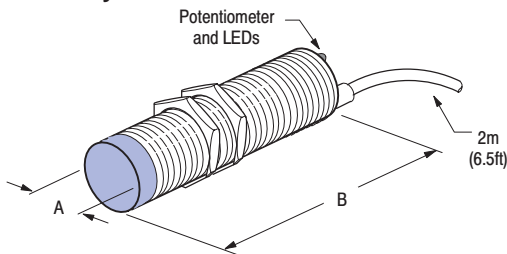

Wiring Diagram

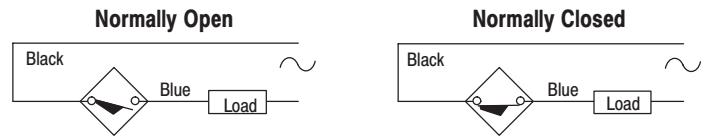

Note: Load can be switched to black wire.

Diameter or Thread Size	mm (inches)	
	A	B
M18 x 1	18.0 (0.71)	52.0 (2.04)
M30 x 1.5	30.0 (1.18)	53.0 (2.08)

Micro QD Style

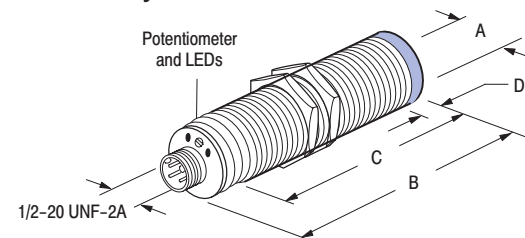

Normally Open or Normally Closed

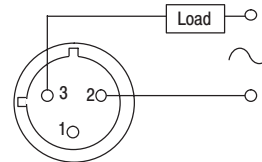

Note: Load can be switched to pin 2.

Diameter or Thread Size	mm (inches)			
	A	B	C	D
M30 x 1.5	30.0 (1.18)	66.0 (2.60)	53.0 (2.08)	1.0 (0.04)

875CP 2-Wire AC

Plastic Face/Threaded or Smooth Plastic Barrel



875CP AC Cable Style
Smooth Barrel
34mm
page R4-19



875CP AC Cable Style
Threaded Barrel
18, 30mm
page R4-19



875CP AC Micro Quick-Disconnect Style
Smooth Barrel
34mm
page R4-20



875CP AC Micro Quick-Disconnect Style
Threaded Barrel
30mm
page R4-20



Specifications

Load Current	≤ 300mA
Inrush Current	2A
Leakage Current	<1.5mA
Operating Voltage	24-240V AC
Voltage Drop	<7.5V AC
Repeatability	≤ 10%
Hysteresis	≤ 20%
Transient Noise Protection	Incorporated
Enclosure	NEMA 1, 3, 4, 6, 13 and IP67
Approval	CE marked for all applicable directives
Connections	Cable: 2-meter length 2-conductor PVC Quick-Disconnect: 3-pin micro
LEDs	Green: Power Yellow: Output
Operating Temperature	-25°C to +70°C (-13°F to +158°F)

Correction Factors

Target Material	Correction Factor
Acetone	0.75
Acrylic Resin	0.10 - 0.25
Air	0.0
Alcohol	0.85
Ammonia	0.70 - 0.85
Aniline	0.40
Aqueous Solutions	0.98 - 1.0
Bakelite	0.20
Benzene	0.10
Carbon Dioxide	0.0
Carbon Tetrachloride	0.10
Celluloid	0.15
Cement Powder	0.25
Cereal	0.15 - 0.30
Chlorine Liquid	0.10
Ebonite	0.15
Epoxy Resin	0.15 - 0.35
Ethanol	0.85
Ethylene Glycol	0.93
Fired Ash	0.05
Flour	0.05
Freon R22 & 502 (liquid)	0.35
Gasoline	0.10
Glass	0.20 - 0.55
Glycerine	0.98
Marble	0.50
Melamine Resin	0.25 - 0.55
Mica	0.35
Nitrobenzine	0.93
Nylon	0.20 - 0.30
Oil Saturated Paper	0.25
Paraffin	0.10
Paper	0.10

Correction Factors

Target Material	Correction Factor
Perspex	0.15
Petroleum	0.05
Phenol Resin	0.20 - 0.60
Polyacetal	0.20
Polyamide	0.30
Polyester Resin	0.15 - 0.50
Polyethylene	0.10
Polypropylene	0.10
Polystyrene	0.15
Polyvinyl Chloride Resin	0.15
Porcelain	0.25 - 0.40
Powdered Milk	0.20
Press Board	0.10 - 0.30
Quartz Glass	0.20
Rubber	0.15 - 0.90
Salt	0.35
Sand	0.15 - 0.30
Shellac	0.15 - 0.25
Shell Lime	<0.05
Silicon Varnish	0.15
Soybean Oil	0.15
Styrene Resin	0.15
Sugar	0.15
Sulphur	0.15
PTFE	0.10
Toluene	0.10
Transformer Oil	0.10
Turpentine Oil	0.10
Urea Resin	0.30 - 0.45
Vaseline	0.10
Water	1.0
Wood, Dry	0.10 - 0.40
Wood, Wet	0.60 - 0.85

Features

- Metal, nonmetal solid and liquid sensing capability
- Adjustable sensing distance
- 2-wire operation
- 2-conductor or 3-pin connection
- 24-240V AC
- Normally open or normally closed output
- Transient noise protection
- CE marked for all applicable directives

Product Selection

Barrel Diameter and Type	Nominal Sensing Distance mm (in)	Shielded	Output Configuration	Switching Frequency (Hz)	Catalog Number	
					Cable Style	Micro QD Style
18mm Threaded	2 (0.08) to 8 (0.31)	N	N.O.	25	875CP-G8N18-A2	—
			N.C.		875CP-G8C18-A2	—
N.O.	875CP-G20N30-A2		875CP-G20N30-R3			
N.C.	875CP-G20C30-A2		875CP-G20C30-R3			
N.O.	875CP-GM30N34-A2		875CP-GM30N34-R3			
N.C.	875CP-GM30C34-A2		875CP-GM30C34-R3			
30mm Threaded	5 (0.20) to 20 (0.79)					
34mm Smooth	7 (0.28) to 30 (1.18)					
Recommended Standard QD Cordset (-2 = 2m (6.5ft))						889R-F3ACA-2

QD Cordsets and Accessories

Description	Page Number
Mounting Brackets	R2-196 - R2-200
Mounting Nuts	R2-207 - R2-208
Sensor Wells	R4-22
Terminal Chambers	NO TAG
Other Cordsets Available	R8-6

Dimensions—mm (inches)

Cable Style

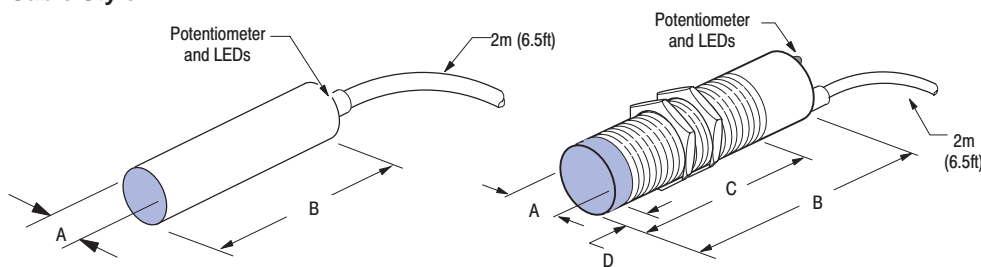

Wiring Diagram

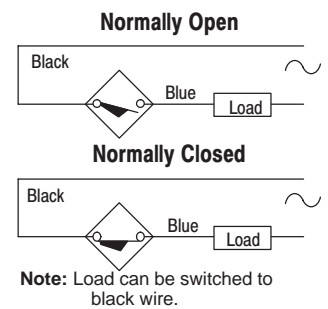

Diameter or Thread Size	mm (inches)			
	A	B	C	D
M18 x 1	18.0 (0.71)	52.0 (2.04)	52.0 (2.04)	1.0 (0.04)
M30 x 1.5	30.0 (1.18)	52.0 (2.04)	46.1 (1.81)	1.0 (0.04)
∅34	34.0 (1.34)	52.0 (2.04)	N/A	N/A

Capacitive Proximity Sensors

875CP 2-Wire AC

Plastic Face/Threaded or Smooth Plastic Barrel

Dimensions—mm (inches)

Micro QD Style

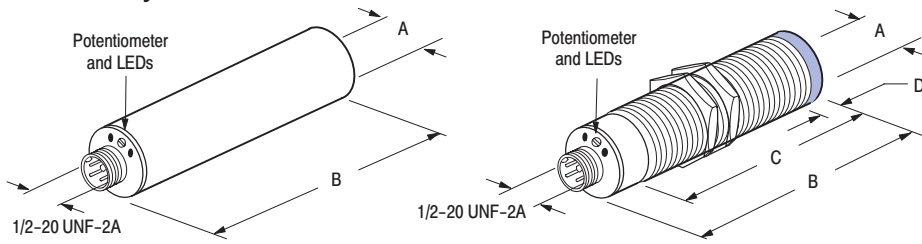

Wiring Diagram

Normally Open or Normally Closed

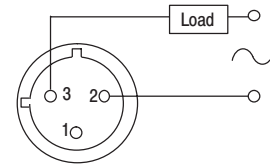

Note: Load can be switched to pin 2.

Diameter or Thread Size	mm (inches)			
	A	B	C	D
M30 x 1.5	30.0 (1.18)	65.0 (2.56)	52.0 (2.04)	1.0 (0.04)
Ø34	34.0 (1.34)	65.0 (2.56)	N/A	N/A

Mounting Brackets for Tubular Proximities—Sight Glass Style

Description

Sight glass style sensor mounts provide simple and convenient mounting of capacitive sensors to sight tubes for high/low level sensing. Sight glass style sensor mounts are available to fit 3/8" through 1 3/4" diameter plastic or glass tubing. These mounts are designed for use with 12mm, 18mm and 30mm diameter capacitive sensors. All sight glass style sensor mounts are made of Delrin™ plastic with stainless steel fasteners and band clamp included.

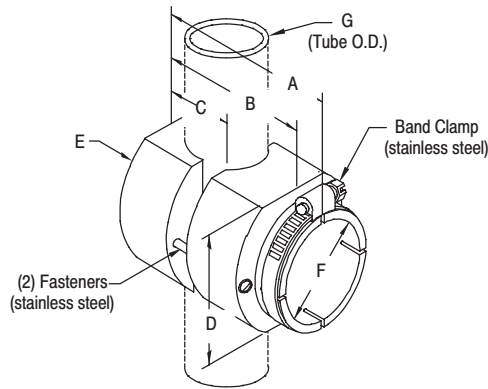
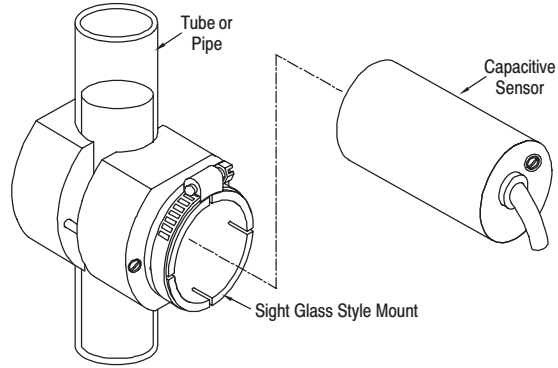

Dimensions—mm (inches)

A	B	C	D	E	F—Sensor Diameter	G—Tube O.D.	Catalog Number
44.5 (1.75)	33.0 (1.30)	12.7 (0.50)	25.4 (1.00)	31.8 (1.25)	12mm (threaded or smooth)	9.40–20.6 (0.37–0.81)	871A–BGD12
48.3 (1.90)	36.8 (1.45)	15.2 (0.60)	31.5 (1.24)	37.5 (1.75)	18mm (threaded or smooth)	16.0–28.4 (0.63–1.12)	871A–BGD18
87.6 (3.45)	76.3 (3.00)	31.8 (1.50)	37.5 (1.75)	50.8 (2.00)	30mm (threaded or smooth)	25.4–44.5 (1.00–1.75)	871A–BGD30

Typical Application

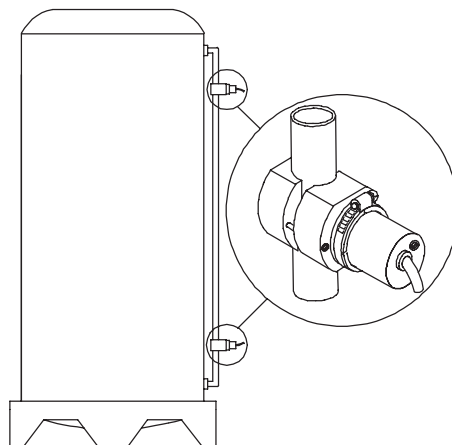

Accessories

Sensor Wells for Capacitive Proximities

Threaded Sensor Well

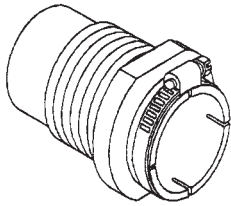

12, 18, 30, 34mm

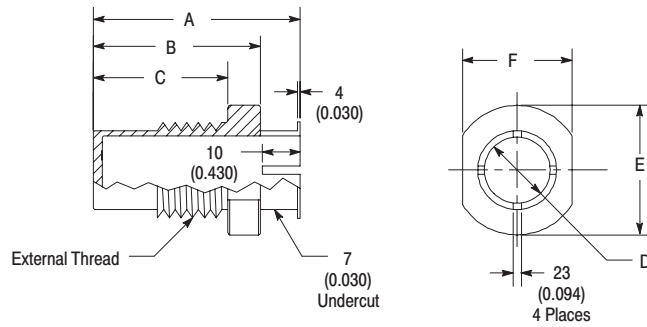

Dimensions—mm (inches)

Sensor Diameter	A	B	C	D	E	F	Pressure Rating (psi)	External Thread	Material	Catalog Number
12mm	44 (1.750)	33 (1.300)	26 (1.050)	11-12 (0.470-0.480)	31 (1.250)	25 (0.995)	200	1/2-14 NPT	Delrin	871A-WTD12
				Teflon®	871A-WTT12					
18mm	59 (2.350)	48 (1.900)	38 (1.530)	18 (0.720-0.725)	37 (1.470)	31 (1.245)		3/4-14 NPT	Delrin	871A-WTD18
				Teflon®	871A-WTT18					
30mm	59 (2.350)	48 (1.900)	38 (1.530)	29-30 (1.180-1.185)	50 (1.970)	44 (1.745)		1-1/4-11.5 NPT	Delrin	871A-WTD30
Teflon®				871A-WTT30						
34mm	59 (2.350)	48 (1.900)	38 (1.530)	34 (1.340-1.345)	69 (2.750)	31 (1.245)		1-1/2-11.5 NPT	Delrin	871A-WTD34
				Teflon®	871A-WTT34					

Bolt-on Sensor Well

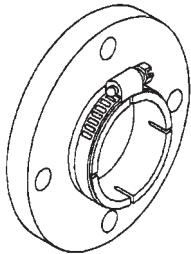

30mm Bolt-on

Material: High Density Polyethylene
Pressure Rating: 150 PSI

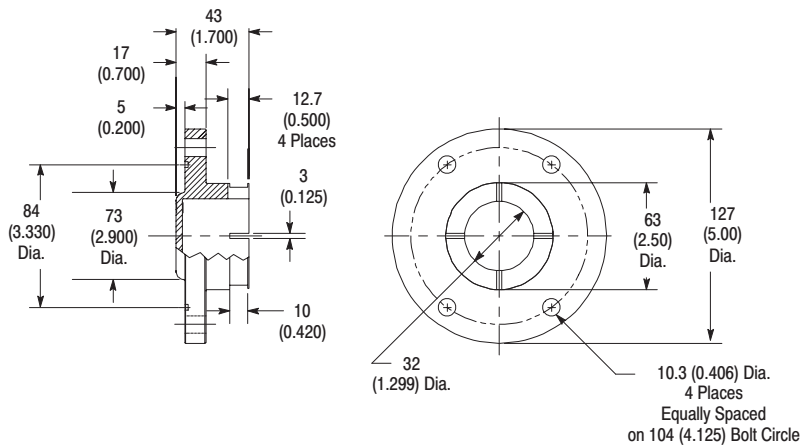

Description	Catalog Number
Bolt on sensor well	871A-WSPE30

Teflon® is a registered trademark of DuPont.

Note: All 871A Series sensor wells are made of FDA approved materials