

Accessories	Intrinsically Safe Zener Diode Barriers	page R10–3
	Intrinsically Safe or Galvanic Isolators	page R10–4
	Intrinsically Safe Wiring Labels	page R10–5
	DIN Mounting Rail	page R10–5
	Sealing Caps	page R10–6
	Coupling Adaptors	page R10–7
	Mounting Accessories	page R10–7
	Power Supplies	page R10–7
Indexes	Catalog Number Index	page R11–1
	Comprehensive Product Index	page R12–1

The Accessories in this section may be used across multiple product lines. Accessories specific to a product line can be found at the end of the respective section.

Barriers and Isolators



Description

For applications involving sensor use in hazardous locations, Rockwell Automation offers a line of Intrinsic Safety Zener Diode Barriers and Galvanic Isolators. Both are economical solutions for instrumentation and control systems in hazardous locations as defined by NEC article 500 and CEC Part I, Section 18.

Zener diode barriers are *passive* protective interface assemblies that limit the amount of energy (voltage and current) that enters a hazardous area in the event of a fault (i.e. overvoltage, shorted field wiring). The energy is limited to an amount that would not be sufficient to ignite the potentially explosive atmosphere. Designed in a slim ½in wide housing, each barrier contains zener diodes that limit the voltage while a resistor prevents excessive current from being transferred to the hazardous area. In the barriers offered by Rockwell

Automation, a replaceable fuse is used to protect the barrier from miswiring and transients.

The principle of a keyed fuse assembly has been employed. In case of a fault due to overvoltage, polarity misconnection or transients, only the protective keyed fuse assembly needs to be replaced.

The replacement of the fuse assembly can be done by the user at the job site. The barriers do not have to be returned to the manufacturer for replacement.

Intrinsically Safe or Galvanic Isolators are *active* protective interface assemblies that limit the amount of energy allowed to enter a hazardous area under fault conditions. Sometimes called Transformer Isolated Barriers, they separate intrinsically safe wiring from non-intrinsically safe wiring through the use of the same isolation coils found in power transformers.

Galvanic isolators, unlike zener diode barriers, do not require grounding—therefore they may reduce ground loop problems as well as installation and maintenance costs. The slim ¾" wide housing on DC models also conserves valuable mounting space. DIP switches provide convenient programming of output and diagnostic functions while multiple LEDs provide visual indication of module and circuit status.

Allen-Bradley's zener diode barriers and galvanic isolators are DIN-rail mountable and designed primarily for use with intrinsically safe proximity sensors and photoelectrics. All of Allen-Bradley's barriers and isolators are FM and CENELEC approved, CSA certified and CE marked for all applicable directives.

Intrinsically Safe Zener Diode Barriers



Specifications

Leakage Current	≤ 1μA
Reverse Polarity Protection	Protected by replaceable fuse
Over Voltage Protection	Protected by replaceable fuse
Replaceable Fuse Rating	160mA
Short Circuit Protection	Incorporated
Enclosure	IP40 (IEC 529)
Housing Material	Polyamide
Mounting Location	Nonhazardous or Class 1, Division 2 location
Operating Temperature	-20°C to +60°C (-4°F to +140°F)
Shock and Vibration	20g, 55Hz (1.5mm amplitude)
Relative Humidity	to 95%, no condensation
Operating Frequency	≤ 100kHz @ I _{sc} > 50mA; ≤ 50kHz @ I _{sc} ≤ 0.50mA
I.S. Connections for	Class I, II, III; Div 1 and 2; Groups A-G

Description

Intrinsic Safety Zener Diode Barriers are passive protective interface assemblies to isolate intrinsically safe circuits from non-intrinsically safe circuits as defined in FM Class No. 3610 and CSA 22.2 No. 157

The Intrinsic Safety Zener Diode Barrier offer economical solutions for instrumentation and control systems in hazardous locations defined by NEC Article 500 and CEC Part I, Section 18.

Features

- Replaceable fuse
- Low internal resistance
- Short circuited protected
- Reverse polarity protection
- Slim 1/2in wide housing
- FM, CSA CENELEC (PTB) approved, and CE marked for all applicable directives

Dimensions—mm (inches)

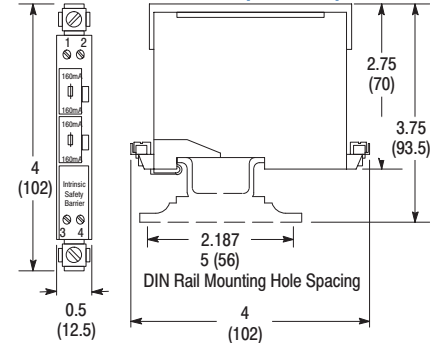

Selection Guide

Rated Voltage	Channel	Internal Resistance	FM Entity Parameters					Catalog Number
			Groups	Voc	Isc	Ca	La	
+24 to +26V DC	1	302 ohms	A, B	28.0V	100.0mA	0.14uF	3.60mH	897H-S120
			C, E			0.43uF	13.9mH	
			D, F, G			1.14uF	28.5mH	
	1	1V @22mA	A, B		0.00mA	0.14uF	1000mH	897H-S140
			C, E		0.43uF			
			D, F, G		1.14uF			
	1	630 ohms	A, B		47.5mA	0.14uF	15.1mH	897H-S150
			C, E		0.43uF	57.0mH		
			D, F, G		1.14uF	125mH		
	1	280 ohms	A, B		109.2mA	0.14uF	2.9mH	897H-S214
			C, E		0.39uF	11.6mH		
			D, F, G		1.04uF	23.6mH		
	2	1V @22mA	A, B		0.00mA	0.14uF	1000mH	
			C, E		0.39uF			
			D, F, G		1.04uF			
	1, 2	340 ohms	A, B		89mA	0.14uF	4.5mH	897H-S233
			C, E			0.43uF	18.1mH	
			D, F, G			1.1uF	37mH	
Replacement Fuse Assembly							897H-F160	

Intrinsically Safe or Galvanic Isolators



Specifications

Application	NAMUR sensors
Number of Inputs	2
Switching Frequency	15Hz
Signal Range	8V @ 8.2mA
Switching Current	On > 2.1mA, Off < 1.2mA
Input Resistance	1000ohms

Description

Intrinsically Safe or Galvanic Isolators are active protective interface assemblies to isolate intrinsically safe circuits from non-intrinsically safe circuits as defined in FM Class No. 3610 and CSA 22.2 No. 157. Galvanic Isolators offer economical solutions for instrumentation and control systems in hazardous locations defined by NEC Article 500 and CEC Part I, Section 18.

Unlike zener diode barriers, galvanic isolators do not require grounding. The solid state output version isolators can be located in a Division 2 area.

Allen-Bradley's galvanic isolators provide 1500 volt isolation between hazardous area and nonhazardous area terminals and 500 volt isolation between input/output and external power terminals. DIP switches provide convenient programming for output or diagnostic functions and multiple LEDs allow easy visual indication of module and circuit status.

Dimensions—mm (inches)

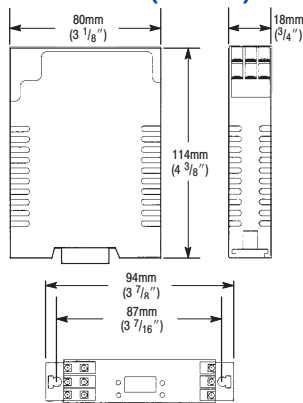

897H-G211, 897H-G231

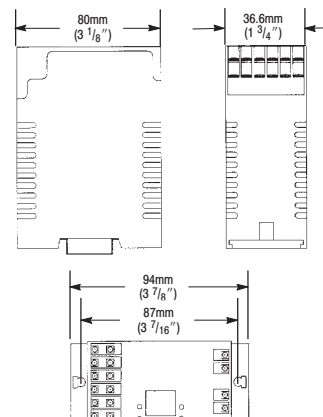

897H-G232

Features

- Reverse polarity protected
- 1500V isolation between input and output
- No separate Intrinsically Safe grounding required
- Slim 3/4in housing (DC models)
- FM, CSA, CENELEC (PTB) approved, and CE marked for all applicable directives

Selection Guide

External Power	Output Type	FM Entity Parameters					Catalog Number				
		Groups	Voc	Isc	Ca	La					
100-140V AC @ 2.5W	SPDT Relay (250V AC @ 4A)	A, B	10.5V	32mA	0.11µF	2.9mH	897H-G232				
		C, E			0.33µF	11.6mH					
		D, F, G			0.88µF	23.6mH					
200-250V AC @ 2.5W	SPST Relay (250V AC @ 2A)	A, B	10.6V	29.7mA	2.5µF	40mH	897H-G231				
		C, E			15µF	150mH					
		D, F, G			2.5µF	40mH					
		18-35V DC @ 32mA			Transistor, open collector (35V DC @50mA)	A, B	15µF	150mH	2.5µF	40mH	897H-G211
						C, E					
						D, F, G					

Intrinsically Safe Wiring Labels/DIN Mounting Rail

Description

It is recommended that wiring for intrinsically safe systems be identified as such through the use of light blue jacketing and/or through appropriate labels. Such labels are required by NEC

Article 504 and ANSI/ISA RP-12.6 to be placed at no more than 25 foot intervals. When installing intrinsically safe equipment the user should refer to

all relevant national standards and/or those standards set forth by the “authority having jurisdiction” at the installation site.

Intrinsically Safe Wiring Labels

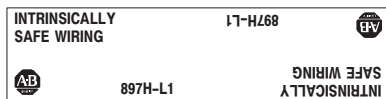

Figure 1



Figure 2

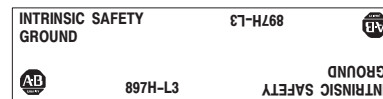

Figure 3

Quantity	Description	Figure	Catalog Number
25	Intrinsically Safe Wiring	1	897H-L1-25
100	Intrinsically Safe Wiring		897H-L1-100
25	Intrinsically Safe Wiring	2	897H-L2-25
100	Intrinsically Safe Wiring		897H-L2-100
25	Intrinsic Safety Ground	3	897H-L3-25

Description

DIN rail provides convenient and simple mounting of barriers, isolators, and other control equipment. DIN rail is available from Rockwell Automation/

Allen-Bradley in one meter sections (catalog number **64-134**) or as part of a mounting kit (catalog number **64-136**). By isolating the DIN rail from the

mounting surface, the mounting kit allows 897H-series shunt diode barriers to be grounded directly to the rail.



#64-136 TS35 DIN Mounting Rail Kit (Barriers not included)



#64-134 TS35 DIN Mounting Rail

Mounting Accessories

Catalog Number	Description
64-134	1m (3.3') prepunched zinc plated and chromated steel Mounting Rail per EN50022/DIN46277 (TS35)
64-136	DIN Rail Mounting Kit includes 12" DIN rail, two insulated standoffs, and two grounding terminals

Accessories
Sealing Caps



Mini and Micro Cap

Connector Style	Material	Thread Config.	Dimensions—mm (in)	Catalog Number	Thread Config.	Dimensions—mm (in)	Catalog Number
Mini	Aluminum	External	<p>7/8in-16UN 2A Threads</p> <p>Gasket</p>	1485A-C1	Internal	<p>7/8in-16UN 2B Threads</p> <p>Gasket</p>	889A-NCAP
Mini-Plus (7 and 8 pin)	Aluminum	External	<p>1in-16UN 2A Threads</p> <p>Gasket</p>	889A-NM2CAP	Internal	<p>1in-16UN 2B Threads</p> <p>Gasket</p>	889A-N2CAP
Mini-Plus (9, 10, and 12 pin)	Aluminum	External	<p>1 1/8in-16UN 2A Threads</p> <p>Gasket</p>	889A-NM13CAP	Internal	<p>1 1/8in-16UN 2B Threads</p> <p>Gasket</p>	889A-N3CAP
DC Micro	Aluminum	External	<p>M12 x 1 Threads</p>	1485A-C3	Internal	<p>M12 x 1 Threads</p> <p>Gasket</p>	889A-DCAP
	Plastic	External	<p>M12 x 1 Threads</p>	1485A-M12	—	—	—
AC Micro	Aluminum	External	<p>1/2in UNF Threads</p>	889A-RMCAP	Internal	<p>1/2in UNF Threads</p> <p>Gasket</p>	889A-RCAP
Pico	Plastic	External	<p>M8 x 1 Threads</p>	889A-PMCAP	—	—	—
M23	Nickel-plated Brass	External	<p>M23 x 1 External Thread</p>	889A-MMCAP	Internal	<p>M23 x 1 External Thread</p>	889A-MCAP

Coupling Adaptors/Mounting Accessories/Power Supplies

Coupling Adaptors

Connector Style	Material	Dimensions—mm (in)	Catalog Number
Mini	Aluminum	<p>7/8in-16UN-2A Threads</p>	889A-NADPT
Mini-Plus (7 and 8 pin)		<p>1-16UN-2A thread</p>	889A-N2ADPT
Mini-Plus (9, 10, and 12 pin)		<p>0.48 1 1/8in-16UN-2A Threads</p>	889A-N3ADPT

Mounting Accessories

Description	Catalog Number
Mounting nuts for 1/2-14NPT threaded receptacles are available in bags of 10 pieces	889A-U1NUT-10
Flat, sealing washers for 1/2-14NPT threaded receptacles are available in bags of 10 pieces	889A-U1FSL-10

Bulletin 1606 Power Supplies Product Selection

	Output Power	Output Voltage	Output Current	Special Feature(s)	Stocked Item	Parallel Operation (Selectable)	Meets EN 61000-3-2 (PFC)	Catalog Number
1606-XLP Compact								
Compact Single Phase	30 W	DC 10...12V	3 A	NEC Class 2	X	—	N/A	1606-XLP30B
		DC 24...28V	1.3 A	NEC Class 2	X	—	N/A	1606-XLP30E
	50 W	DC 12...15V	4.2 A	Output Voltage Adjustable NEC Class 2	X	—	N/A	1606-XLP50B
		DC 24...28V	2.1 A	NEC Class 2	X	—	N/A	1606-XLP50E
		DC 24...28V	3 A	NEC Class 2	X	—	N/A	1606-XLP72E
1606-XL Standard Single Phase								
Standard Single Phase	60 W	DC 24V	2.5 A	NEC Class 2	X	—	N/A	1606-XL60D
	120 W		5 A	—	X	—	Yes	1606-XL120D
	240 W	DC 24...28V	10 A	FM Class 1 Div. 2 T3A	X	—	Yes	1606-XL240EP

Other power supplies are located at www.ab.com/catalogs—select *Industrial Control/New!* – English/Power Supplies.

Discount Schedule A8

Notes
