



General Specifications

Sensing Mode	Diffuse, polarized retroreflective, wide angle diffuse, sharp cutoff diffuse
Light Source	See Product Selection on page R1-44
Unit Protection	Overload, short-circuit, reverse polarity, false pulse
Supply Voltage	10-30V DC
Current Consumption	35mA maximum
Output Type	NPN or PNP by model Both NPN and PNP (44RSP-2xBxx-xx models)
Output Mode	Light or dark operate by catalog number
Output Rating	30V DC, 100mA
Max Leakage Current	0.1mA
Response Time	10ms
Front Housing Material	Valox®
Lens Material	Acrylic
LED Indicators	See below
Connection Types	2m, 24AWG 300V PVC cable, 4-pin DC micro QD
Supplied Accessories	75012-097-01 18mm locknut
Optional Accessories	Mounting brackets, reflectors, cordsets—see page R1-44
Operating Environment	NEMA 12, IP 54
Vibration	10-55Hz, 1mm amplitude, Meets or exceeds IEC 60947-5-2
Shock	30G with 1ms pulse duration, Meets or exceeds IEC 60947-5-2
Operating Temperature	0°C to +50°C (+32°F to +122°F)
Relative Humidity	5...95%
Approvals	UL listed, cUL, CE marked for all applicable directives

Features

- Narrow 27mm deep housing
- 18mm nose and through-hole mounting options
- LED indicators with 360° visibility
- No user adjustments required
- Multiple sensing modes
- Low voltage 24V DC operation
- Variety of connection types

LED Indicators

Label	Color	State	Status
Output	Yellow	OFF	Sensor output de-activated
		ON	Sensor output activated
Margin	Red	OFF	Margin < 1.2
		ON	Margin > 1.2
Power	Green	OFF	Sensor not powered
		ON	Sensor powered

Wiring Diagrams

Models with Dual NPN and PNP Outputs

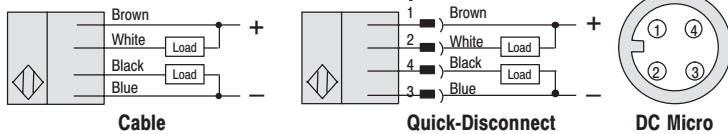

Models with NPN Outputs

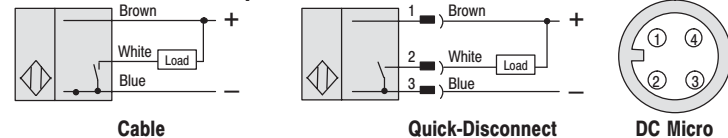

Models with PNP Outputs

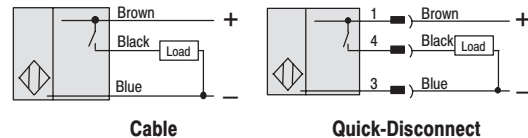

ⓘ All wire colors on quick-disconnect models refer to Allen-Bradley 899D cordsets.

Dimensions—mm (inches)

Polarized Retroreflective and Standard Diffuse Models

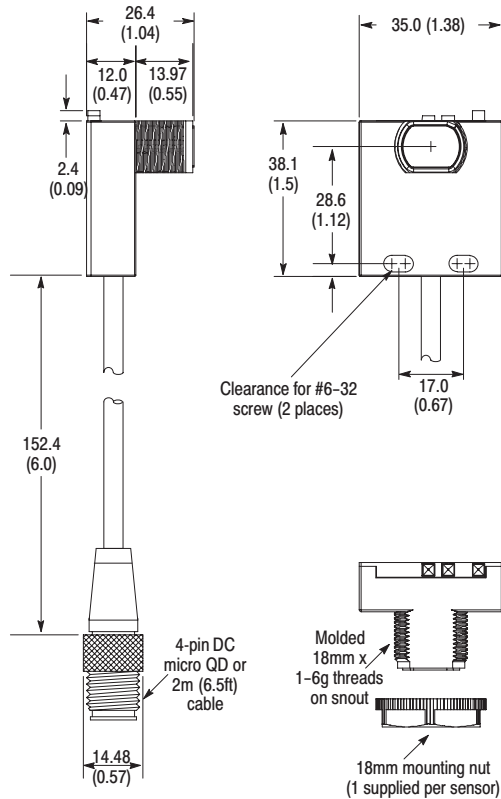

Wide Angle Diffuse Models

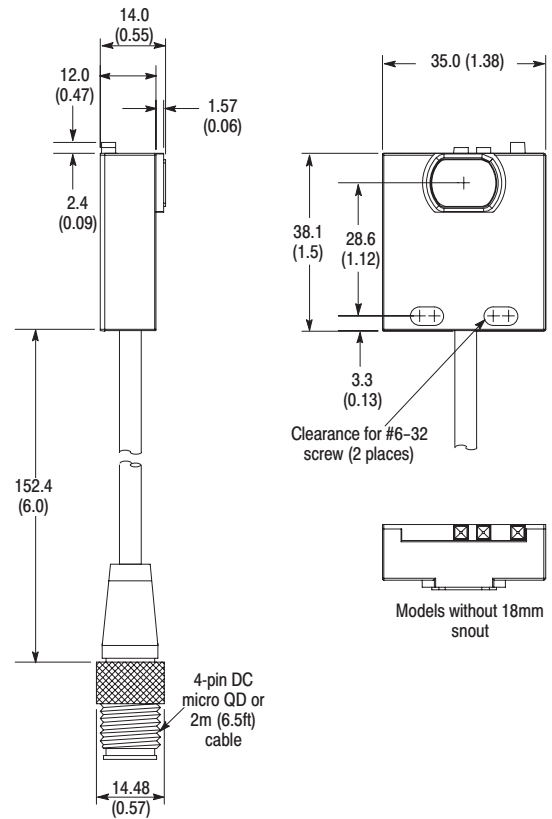

Note: All sensors except wide angle diffuse models are supplied with one M18 mounting nut (catalog number 75012-097-01).

Typical Response Curve Beam Pattern

Polarized Retroreflective

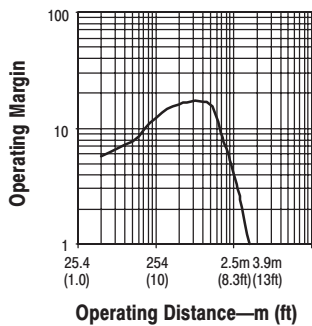

Typical Response Curve Beam Pattern

Sharp Cutoff Diffuse

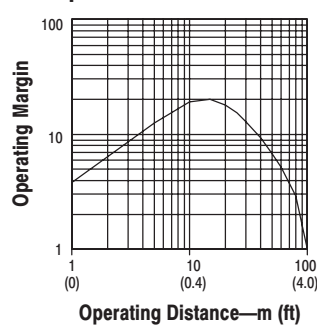

Standard Diffuse

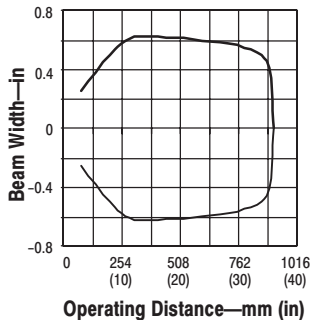
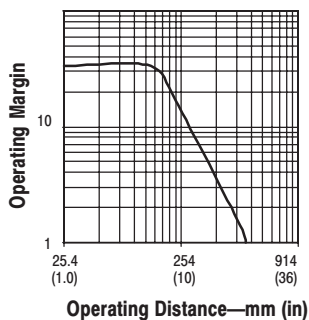

Wide Angle Diffuse

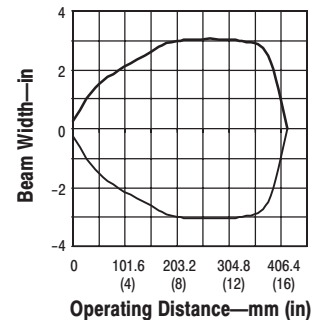
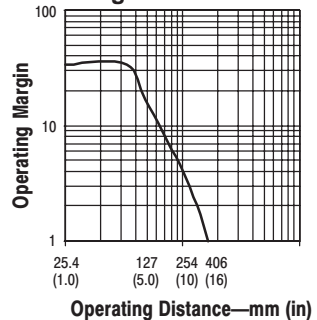

Product Selection

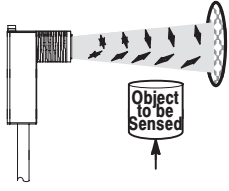
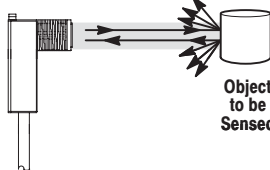
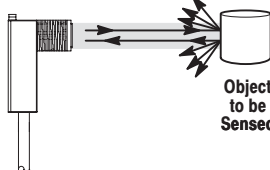
Sensing Mode	Operating Voltage/ Current	Sensing Distance	Output Energized	Output Type/ Capacity Response Time	Connection Type	Catalog Number		
 <p><i>Polarized Retroreflective</i> Field of View: 1.5° Emitter LED: Visible red 660nm</p>	10-30V DC 35mA	25mm (1in) to 1.5m (4.9ft)	Dark Operate	NPN and PNP 100mA 10ms	2m 300V cable	44RSP-2KBE1-A2		
					4-pin DC micro	44RSP-2KBE1-F4		
		25mm (1in) to 3m (9.8ft)	Light Operate		2m 300V cable	44RSP-2JBE3-A2		
					4-pin DC micro	44RSP-2JBE3-F4		
			Dark Operate		2m 300V cable	44RSP-2KBE3-A2		
					4-pin DC micro	44RSP-2KBE3-F4		
		Light Operate	NPN/100mA 10ms	2m 300V cable	44RSP-2JNE3-A2			
				4-pin DC micro	44RSP-2JNE3-F4			
			PNP/100mA 10ms	3-pin Molex	44RSP-2JNE3-Z6			
				2m 300V cable	44RSP-2JPE3-A2			
	4-pin DC micro	44RSP-2JPE3-F4						
 <p><i>Standard Diffuse</i> Field of View: 5° Emitter LED: Infrared 880nm</p>	10-30V DC 35mA	3mm (0.12in) to 380mm (15in)	Light Operate	NPN/100mA 10ms	2m 300V cable	44RSD-1JNC38-A2		
					4-pin DC micro	44RSD-1JNC38-F4		
				PNP/100mA 10ms	2m 300V cable	44RSD-1JPC38-A2		
					4-pin DC micro	44RSD-1JPC38-F4		
 <p><i>Sharp Cutoff Diffuse</i> Field of View: 5° Emitter LED: Infrared 880nm</p>	10-30V DC 35mA	3mm (0.12in) to 100mm (4in)	Light Operate	NPN/100mA 10ms	2m 300V cable	44RSS-1JNB1-A2		
					4-pin DC micro	44RSS-1JNB1-F4		
					Wide Angle Diffuse	NPN/100mA 10ms	2m 300V cable	44RSW-1JNC20-A2
							4-pin DC micro	44RSW-1JNC20-F4
PNP/100mA 10ms	2m 300V cable	44RSW-1JPC20-A2						
	4-pin DC micro	44RSW-1JPC20-F4						

Cordsets and Accessories

Description	Catalog Number	Description	Catalog Number
DC Micro QD Cordset, Straight, 4-pin, 2m	889D-F4AC-2	Right Angle Mounting Bracket	60-2657
76mm (3in) Diameter Reflector	92-39	Mounting Screws (not supplied)	2 x #6-32
32mm (1.25in) Diameter Reflector	92-47		