



### General Specifications

<b>Sensor Input</b>	24V DC, 2- or 3-wire, sinking (NPN)
<b>Actuator Output Type</b>	24V DC, 2-wire, sinking (NPN), 24V DC, 100mA
<b>Response Time</b>	1ms
<b>Zone Logic</b>	Switch selectable single or basic operating modes for zero and low pressure accumulation with singulation and slug release
<b>Advanced Zone Logic</b>	JAM respond function, sleep function, air-to-drive or air-to-brake operation, ON/OFF time delays
<b>Unit Protection</b>	Output short-circuit protection (SCP), over voltage, reverse polarity
<b>Operating Voltage, Current</b>	24V DC, 16mA maximum (excluding load current)
<b>Time Delay(s)</b>	Configurable 0 to 20 second ON and OFF delays
<b>Housing Material</b>	Valox®
<b>LED Indicators</b>	Orange (zone status, fault)
<b>Connection Types</b>	Input: 3-pin MOLEX®; Output: 4-pin MOLEX®; Power/Signal: IDC Flat Cable
<b>Required Accessories</b>	Sensing Device, Actuating Device, Flat Media
<b>Operating Environment</b>	NEMA 1, IP 20 (IEC 529)
<b>Vibration</b>	10-55Hz, 1mm amplitude, Meets or exceeds IEC 947-5-2
<b>Shock</b>	30G with 1ms pulse duration, Meets or exceeds IEC 947-5-2
<b>Operating Temperature</b>	0°C to 50°C (+32°F to 122°F)
<b>Relative Humidity</b>	5% to 85%, noncondensing
<b>Approvals</b>	UL, c-UL listed, CE marked for all applicable directives

### Description

The 22ZC Zone Controller bridges the gap between the 44N Zone Control Sensor and the 1799 embedded I/O module solutions. It offers the simplicity of a smart sensor, yet provides many of the advanced zone logic functions found in a networked, programmable device.

By placing the zone logic in a single zone controller, the user is given the flexibility to choose from a variety of both sensor input types (mechanical, optical) and actuator types (pneumatic, powered roller, DC motor).

The 22ZC uses a proven, industrial, IDC displacement flat media scheme for a high power transfer to maximize the number of zones connected to a single power supply.

The 22ZC offers two basic, switch selectable operating modes. First, is the single zone operation which is a run-on-demand system ideally suited for powered roller and DC motor applications. The second is a basic mode which provides a constant drive for both zero and low pressure accumulation.

Other advanced logic functions include selectable ON (RUN) and OFF (STOP) time delays, power conservation, jam detection, along with air-to-drive and air-to-brake operation.

### Dimensions—mm (inches)

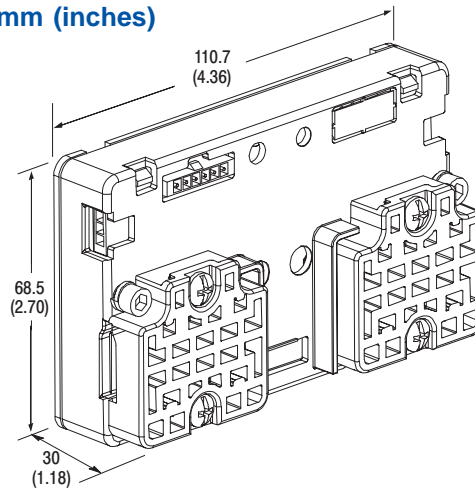

### Product Selection

Description	Catalog Number	Description	Catalog Number	Description	Catalog Number
Zone Controllers	22ZC-413 (master)	Flat Media, 75m spool	1485C-P1L75	Reflector, 3in diameter	92-39
	22ZC-223 (basic)	PowerSupply, 24V DC/4A	XL120E-3	Pneumatic Valve, 3-way	Contact Rockwell Automation
	22ZC-343 (infeed)	Power Tap	22ZC-PWR	Powered Roller Amplifier	
Photoelectric Sensor	44RSP-2JNE3-Z6	Power Tap, IDC	1485T-P1H4-B2C2X	Mounting Bracket, sensor	60-2657

**System Overview for Pneumatically Driven Conveyor Systems**

Install one 22ZC in each zone of the conveyor and attach a suitable sensing and actuating device. Note that the infeed and discharge zones must be terminated with the **22ZC-343** and **22ZC-413** types of controller respectively. Size, cut and install the flat media between each controller. Connect to a suitable 24V DC power supply to any controller within the system. It is recommended to make this connection to the center controller for maximum power distribution. A 4A supply will provide power for up to 25 zones when using a 1W pneumatic valve. Wire the infeed and discharge zone external connections as required using the wiring diagram to the right. Note that the zone and slug release, and the zone feed pushbuttons should be normally open and maintained.

**Loading Product Onto the Conveyor**

With power applied to the system, all zones will immediately drive feeding product onto the conveyor. As product passes the sensor mounted at the infeed zone, a gap will be formed equal to the zone length. This will ensure zero pressure throughout the system. Once the first product reaches the discharge zone (1), it will stop and await release from the conveyor.

**Release of Product**

Once product has been transported and accumulated at the discharge end of the conveyor (Zone 1), it may be released in one of three manners.

**Singulation Release**

With the zone release pushbutton closed and maintained, only product in the discharge zone (1) will release. As the product clears the sensor, the adjacent upstream zones will advance into the discharge zone. Product will continue to discharge as long as the zone release pushbutton remains closed.

**Slug Release**

With the slug release pushbutton closed and maintained, all accumulated product on the conveyor will release simultaneously. When the slug release pushbutton is released, the remaining product will resume normal accumulation. Predetermined slug lengths can be configured through the use of the SLUG RESPOND switch on each controller.

**Figure 1. System Overview**

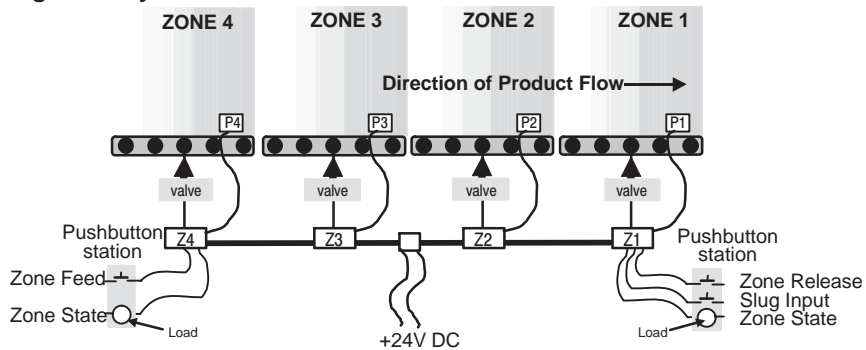

**Figure 2. Loading the Conveyor**

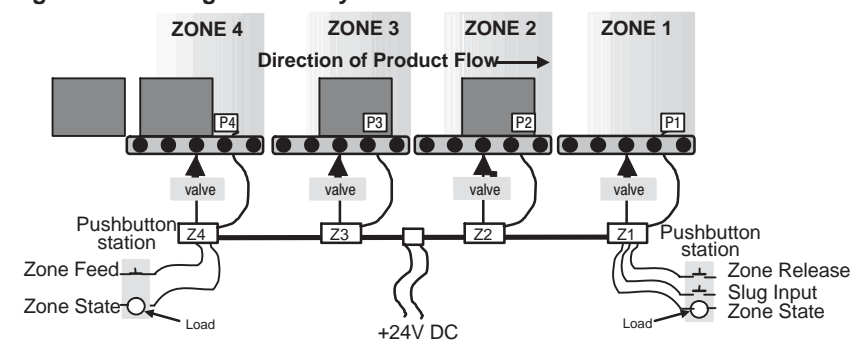

**Figure 3. Singulation Release of Accumulated Product**

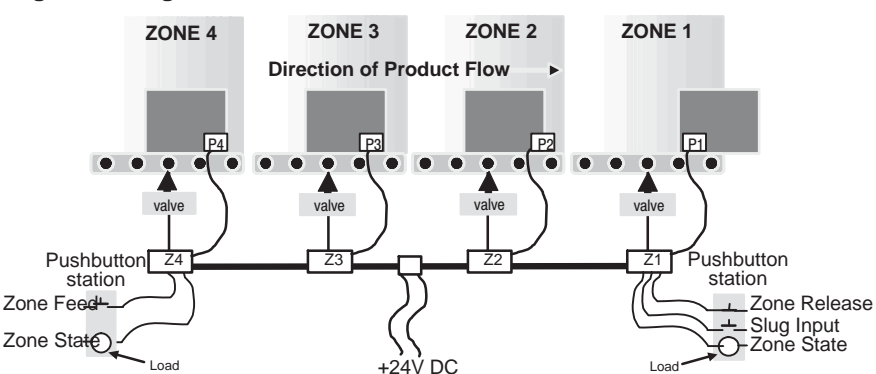

**Figure 4. Slug Release of Accumulated Product**

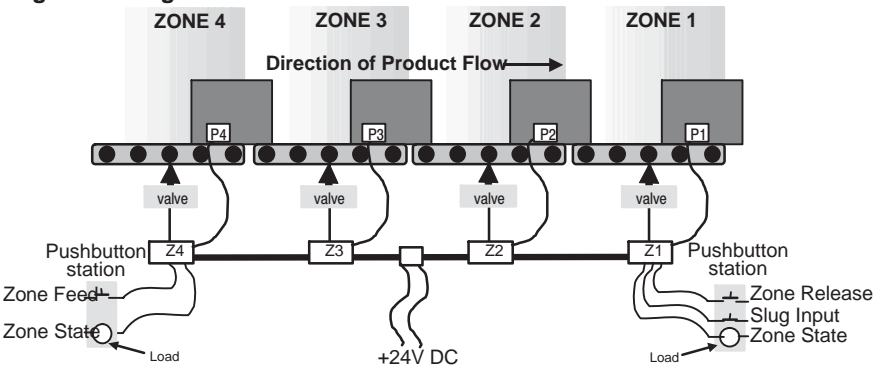

Refer to Rockwell Automation publication 75045-017-01, *Bulletin 22ZC Zone Controller User Manual* for

complete selection, installation, operation and maintenance information.

### System Overview for Powered Roller Driven Conveyor Systems

Install one 22ZC in each zone of the conveyor and attach a suitable sensing and actuating device. Size, cut and install the flat media between each controller. Using a 22ZC-PWR cordset, connect to a suitable 24V DC power supply to any controller within the system. It is recommended to make this connection to the center controller for maximum power distribution. A 4A supply will provide power for up to 50 zones. Note that the power for the powered roller and amplifier are not provided by the 22ZC, only the RUN signal. Wire the infeed and discharge zone external connections as required using the wiring diagram to the right. Note that the zone and slug release, and the zone feed pushbuttons should be normally open and maintained.

### Loading Product onto the Conveyor

With power applied to the system, all zones will be OFF until either the infeed sensor is blocked or the zone feed contact is closed and maintained. As product passes the sensor mounted at the infeed zone, a gap will be formed equal to the zone length. This will ensure zero pressure throughout the system. Once the first product reaches the discharge zone (1), it will stop and await release from the conveyor. If a low pressure accumulation is desired, a system-wide, 1 second OFF time delay can be configured to minimize product spacing on the conveyor.

### Release of Product

Once product has been transported and accumulated at the discharge end of the conveyor (Zone 1), it may be released in one of two manners.

### Singulation Release

With the zone release pushbutton closed and maintained, only product in the discharge zone (1) will release. As the product clears the sensor, the adjacent upstream zones will advance into the discharge zone. Product will continue to discharge as long as the zone release pushbutton remains closed.

### Slug Release

With the slug release pushbutton closed and maintained, all accumulated product on the conveyor will release simultaneously. When the slug release pushbutton is released, the remaining product will resume normal accumulation. Predetermined slug lengths can be configured through the use of the SLUG RESPOND switch on each controller.

Figure 1. System Overview

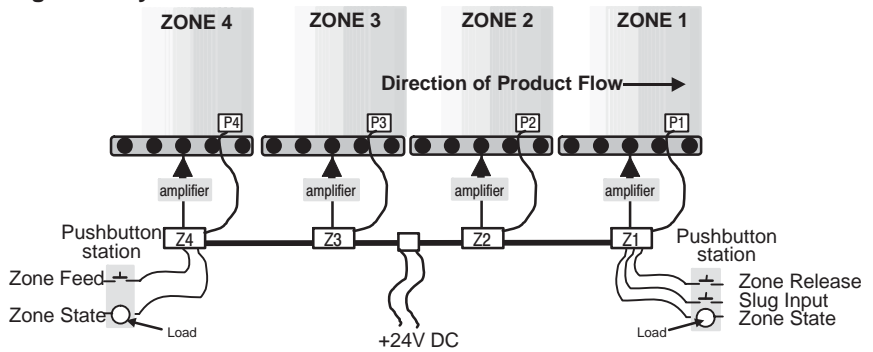

Figure 2. Loading the Conveyor

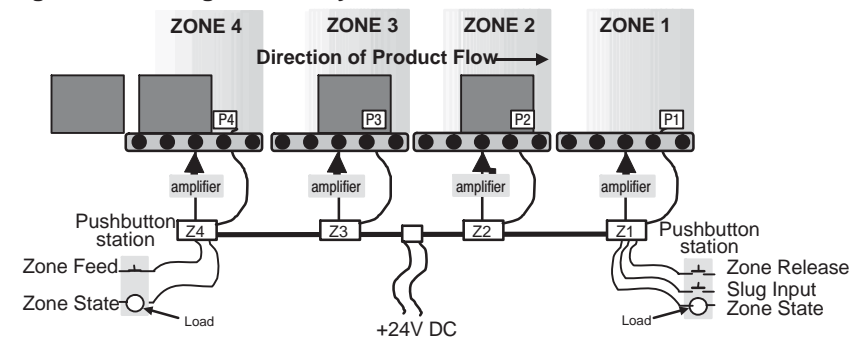

Figure 3. Singulation Release of Accumulated Product

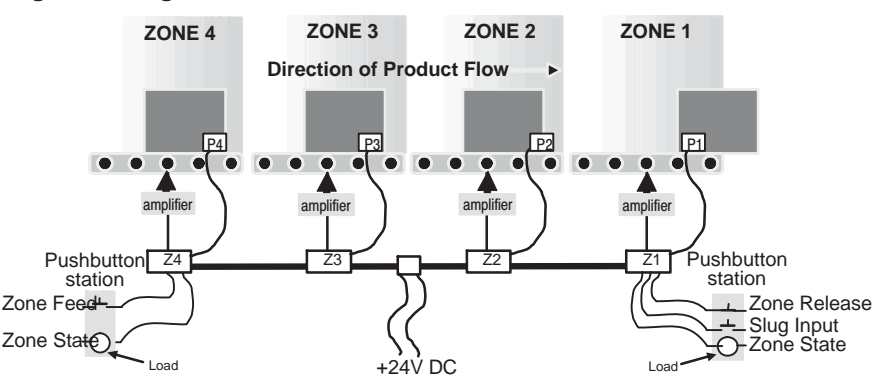
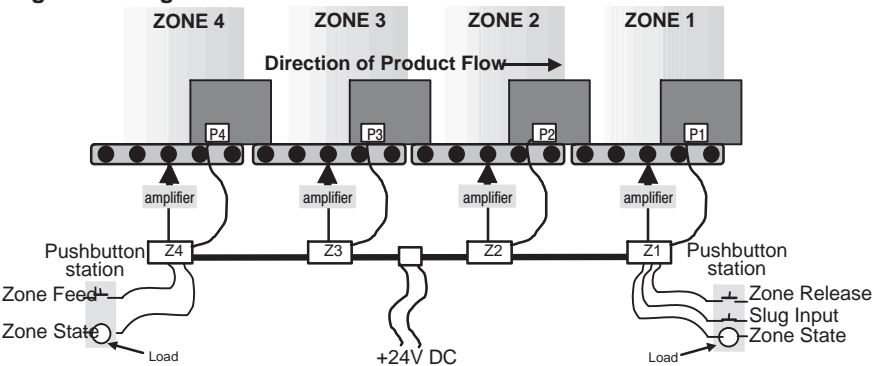

Figure 4. Slug Release of Accumulated Product



Refer to RA publication 75045-017-01 for complete selection, installation, operation, and maintenance information.