

Troubleshooting Using Bias Voltage

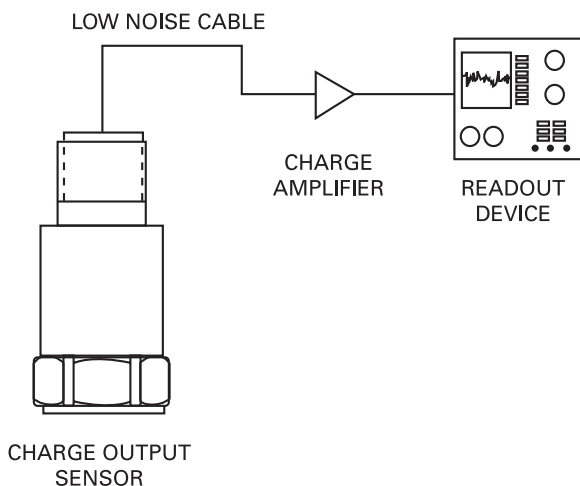

Using Bias Voltage as a Diagnostic Tool Piezoelectric sensors are dynamic measuring equipment. They use piezoelectric sensing elements to convert or transduce the mechanical phenomena to an electrical signal. The mechanical parameter may be force, pressure, or vibration. The raw electrical signal from a piezoelectric element is a high impedance charge signal. This charge signal is normally converted to a low impedance voltage signal by either an external charge amplifier or an external voltage amplifier. The cables between the charge sensor and the amplifier must be high quality, low noise cable and must be kept as short as possible.



Internally amplified sensors, or ICP® sensors, employ miniature amplifiers to convert the high impedance charge signal into a low impedance voltage signal. These amplifiers are internal to the sensor and therefore do not require low noise cables or external amplifiers. These amplifiers have set gain so that output sensitivities are standardized.

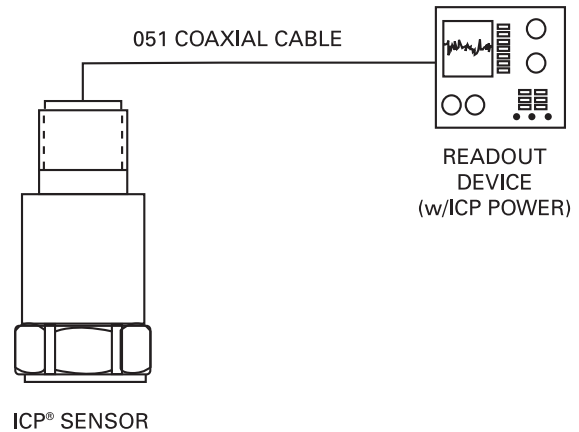

ICP® sensors are two wire sensors. They are powered with a constant current DC source. The power supply is typically 18 to 30 volts DC current limited via a constant current diode between 2 and 20 mA. Typical battery operated supplies offer 2 mA of constant current to extend battery life while continuous monitoring systems offer more current in order to drive longer cables.

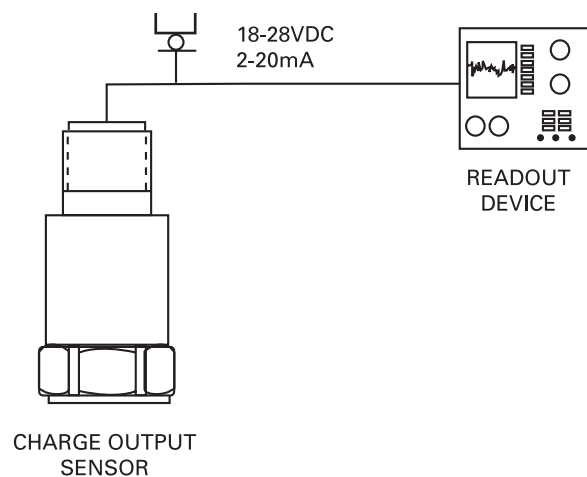

The signal output of an ICP® sensor is a low impedance voltage signal proportional to the dynamic measurement such as force, pressure, or vibration. This voltage signal is carried on a DC bias voltage. The AC dynamic signal is superimposed on the DC bias voltage and is allowed to swing between the supply voltage and ground. Unlike an operational amplifier (Op Amp) that requires a plus and minus supply and allows the signal to "ride" on ground and "swing" between the plus and minus "rails," the ICP® sensor requires the output signal to be DC biased.

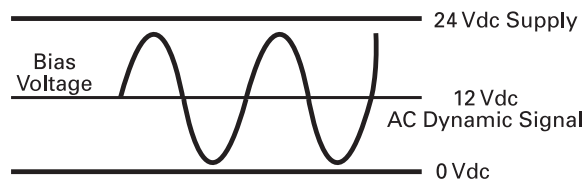

This DC bias voltage is an excellent diagnostic tool. The voltage provides a means of verifying that the amplifier is "turned on." Typical input/output power supplies will block this DC bias voltage at the output via a blocking capacitor in order to AC couple the signal to readout devices. By "teeing" off the input into a DC volt meter, the bias voltage can be measured. While measuring the supply voltage, the bias voltage can be measured after the sensor is plugged in. If the meter stays at supply, something in the system is open or not connected. If the meter reads "0," something in the system is shorted. If the meter reads approximately one-half the supply voltage, then the sensor and cabling are functioning properly.

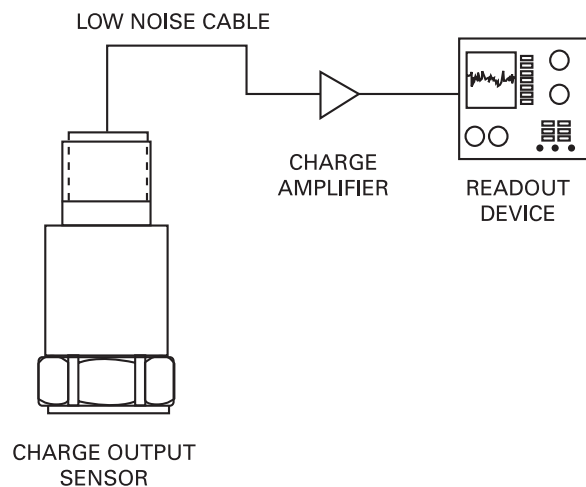

REFERENCES

1. PCB PIEZOTRONICS Inc.

Reprinted with permission from PCB PIEZOTRONICS Inc.

Reach us now at www.rockwellautomation.com or www.entek.com

Rockwell Automation Americas Headquarters, 1201 South Second Street, Milwaukee, WI 53204, USA, Tel: (1) 414 382-2000, Fax: (1) 414 382-4444

Entek Americas -- 1700 Edison Drive, Milford, OH 45150, USA, Tel: (1) 513 576-6151, Fax: (1) 513 576-6104

Entek Europe -- Bumpers Lane, Sealand Industrial Estate, Chester CH1 4LT, UK, Tel: +44 (0) 1244 374914, Fax: +44 (0) 1244 379870

Entek is a trademark of Entek International Corporation

ICP is a registered trademark of PCB Piezotronics, Inc. Other trademarks are the property of their respected owners.

Publication ENACC-AT983A-EN-E – January 2001

